

# Tank, Horizontal Bare

STHGB30063    STH2B30063  
 STHDB30063    STH3B30063  
 STHEB30063



## Design

- STHGB Carbon Steel, Glass Lined  
Primed Painted Exterior  
Five-Year Tank Limited Warranty
- STHDB Carbon Steel, Double-Glass Lined  
Primed Painted Exterior  
Ten-Year Tank Limited Warranty
- STHEB Carbon Steel, Epoxy Lining  
Primed Painted Exterior  
One-Year Tank Limited Warranty
- STH2B Duplex Stainless Steel  
Twenty-Five-Year\* Tank Limited Warranty  
\*See warranty sheet for details
- STH3B 316L Stainless Steel  
Ten-Year Tank Limited Warranty

## Submittal Data

Date:

Project #:

Engineer:

Project Name:

Prepared By:

Location:

Bid Date:

Contractor:

Code	ASME Sec IV HLW
Design Pressure	125 psi
Parts Warranty	One Year, Limited
Supports	Saddles
Capacity	175 Gallons
Nominal Capacity	193 Gallons
Weight	365 Lbs.

## Dimensions

Callout	Value	Description
A	63"	Overall Length
B	39"	Overall Height
C	30"	Diameter
D	18"	Circulation
E	18"	Supports
F	26.38"	Support Width

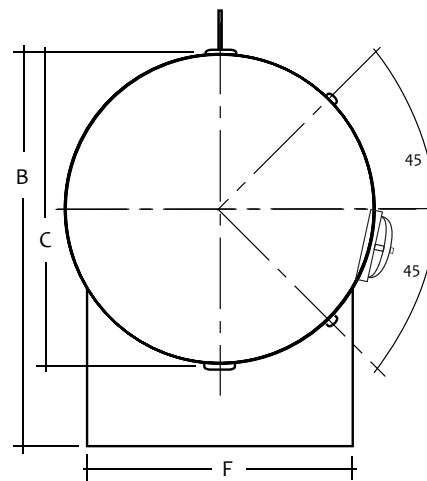
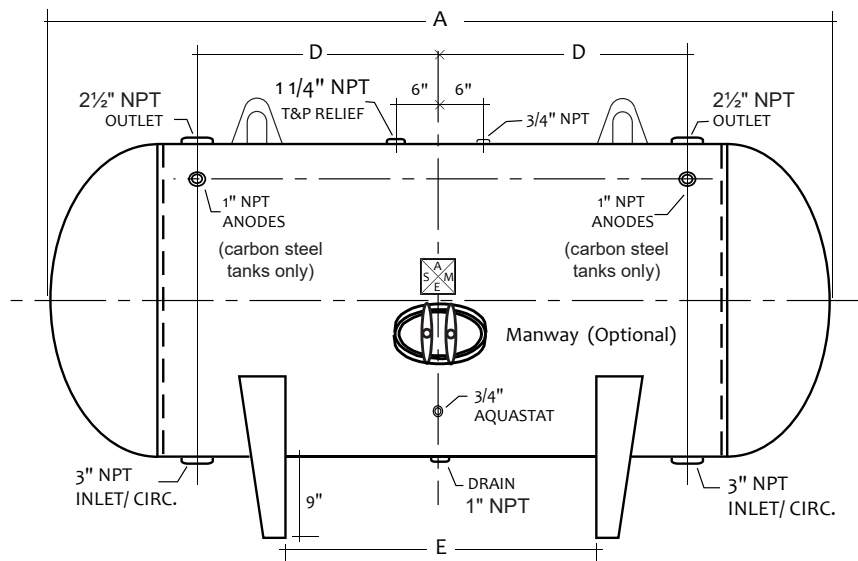

## Options

- 150 PSI Vessel
- Hand Hole
- Optional Fittings / Additional Notes:



Customer Service and Product Support: 800.900.9276 • Fax 800.559.1583  
 Headquarters: 20 Industrial Way, Rochester, NH, USA 03867 • 603.335.6300 • Fax 603.335.3355  
 9 Brigden Gate, Halton Hills, Ontario, Canada L7G 0A3 • 905.203.0600 • Fax 905.636.0666

[www.Laars.com](http://www.Laars.com)

Litho in U.S.A. © Laars Heating Systems 20-09 Document 4223F

# Tank, Horizontal Bare

STHGB30075    STH2B30075  
 STHDB30075    STH3B30075  
 STHEB30075



## Design

- STHGB Carbon Steel, Glass Lined  
Primed Painted Exterior  
Five-Year Tank Limited Warranty
- STHDB Carbon Steel, Double-Glass Lined  
Primed Painted Exterior  
Ten-Year Tank Limited Warranty
- STHEB Carbon Steel, Epoxy Lining  
Primed Painted Exterior  
One-Year Tank Limited Warranty
- STH2B Duplex Stainless Steel  
Twenty-Five-Year\* Tank Limited Warranty  
\*See warranty sheet for details
- STH3B 316L Stainless Steel  
Ten-Year Tank Limited Warranty

## Submittal Data

Date:

Project #:

Engineer:

Project Name:

Prepared By:

Location:

Bid Date:

Contractor:

Code	ASME Sec IV HLW
Design Pressure	125 psi
Parts Warranty	One Year, Limited
Supports	Saddles
Capacity	210 Gallons
Nominal Capacity	229 Gallons
Weight	412 Lbs.

## Dimensions

Callout	Value	Description
A	75"	Overall Length
B	39"	Overall Height
C	30"	Diameter
D	24"	Circulation
E	24"	Supports
F	26.38"	Support Width

## Options

- 150 PSI Vessel
- Hand Hole
- Optional Fittings / Additional Notes:

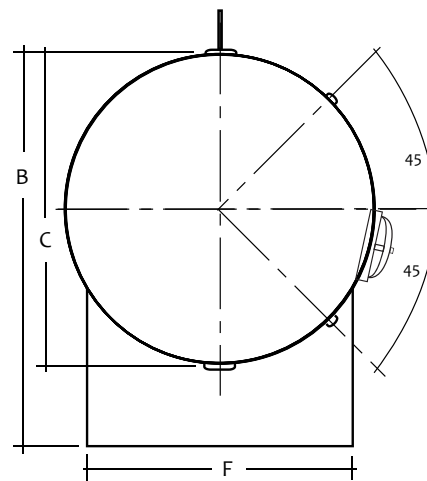
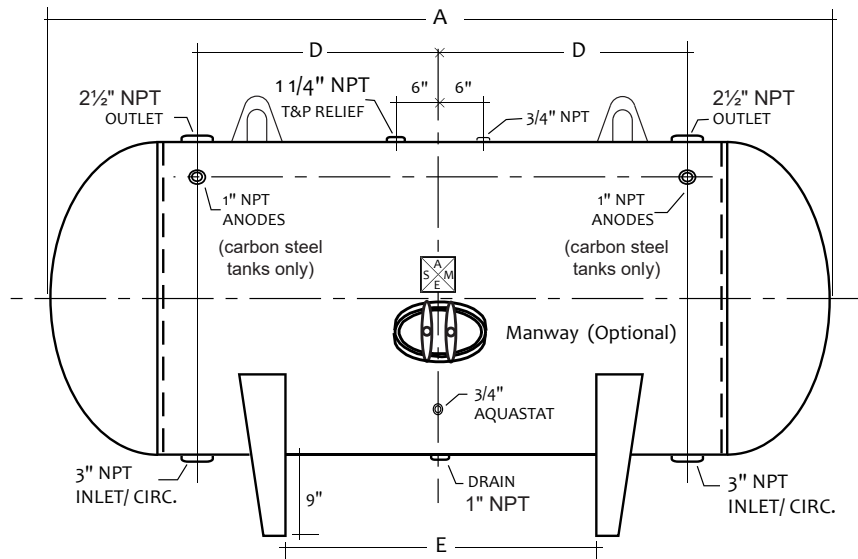

Customer Service and Product Support: 800.900.9276 • Fax 800.559.1583  
 Headquarters: 20 Industrial Way, Rochester, NH, USA 03867 • 603.335.6300 • Fax 603.335.3355  
 9 Brigden Gate, Halton Hills, Ontario, Canada L7G 0A3 • 905.203.0600 • Fax 905.636.0666  
[www.Laars.com](http://www.Laars.com)      Litho in U.S.A. © Laars Heating Systems 20-09 Document 4223F

# Tank, Horizontal Bare

STHGB30085    STH2B30085  
 STHDB30085    STH3B30085  
 STHEB30085



## Design

- STHGB Carbon Steel, Glass Lined  
Primed Painted Exterior  
Five-Year Tank Limited Warranty
- STHDB Carbon Steel, Double-Glass Lined  
Primed Painted Exterior  
Ten-Year Tank Limited Warranty
- STHEB Carbon Steel, Epoxy Lining  
Primed Painted Exterior  
One-Year Tank Limited Warranty
- STH2B Duplex Stainless Steel  
Twenty-Five-Year\* Tank Limited Warranty  
\*See warranty sheet for details
- STH3B 316L Stainless Steel  
Ten-Year Tank Limited Warranty

## Submittal Data

Date:

Project #:

Engineer:

Project Name:

Prepared By:

Location:

Bid Date:

Contractor:

Code	ASME Sec IV HLW
Design Pressure	125 psi
Parts Warranty	One Year, Limited
Supports	Saddles
Capacity	240 Gallons
Nominal Capacity	260 Gallons
Weight	545 Lbs.

## Dimensions

Callout	Value	Description
A	85"	Overall Length
B	39"	Overall Height
C	30"	Diameter
D	29"	Circulation
E	34"	Supports
F	26.38"	Support Width

## Options

- 150 PSI Vessel
- Hand Hole
- Optional Fittings / Additional Notes:

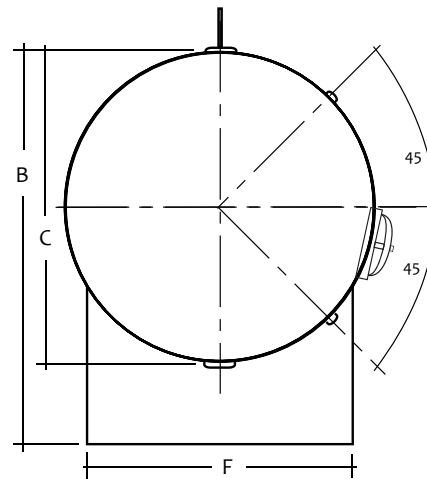
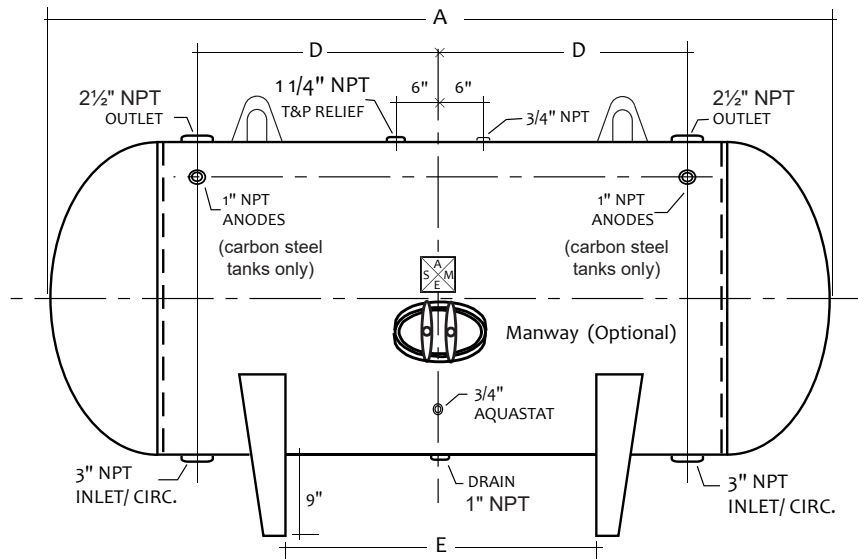

Customer Service and Product Support: 800.900.9276 • Fax 800.559.1583  
 Headquarters: 20 Industrial Way, Rochester, NH, USA 03867 • 603.335.6300 • Fax 603.335.3355  
 9 Brigden Gate, Halton Hills, Ontario, Canada L7G 0A3 • 905.203.0600 • Fax 905.636.0666  
[www.Laars.com](http://www.Laars.com)    Litho in U.S.A. © Laars Heating Systems 20-09 Document 4223F

# Tank, Horizontal Bare

STHGB30099

STH2B30099

STHDB30099

STH3B30099

STHEB30099



## Design

- STHGB Carbon Steel, Glass Lined  
Primed Painted Exterior  
Five-Year Tank Limited Warranty
- STHDB Carbon Steel, Double-Glass Lined  
Primed Painted Exterior  
Ten-Year Tank Limited Warranty
- STHEB Carbon Steel, Epoxy Lining  
Primed Painted Exterior  
One-Year Tank Limited Warranty
- STH2B Duplex Stainless Steel  
Twenty-Five-Year\* Tank Limited Warranty  
\*See warranty sheet for details
- STH3B 316L Stainless Steel  
Ten-Year Tank Limited Warranty

## Submittal Data

Date:

Project #:

Engineer:

Project Name:

Prepared By:

Location:

Bid Date:

Contractor:

Code	ASME Sec IV HLW
Design Pressure	125 psi
Parts Warranty	One Year, Limited
Supports	Saddles
Capacity	280 Gallons
Nominal Capacity	303 Gallons
Weight	508 Lbs.

## Dimensions

Callout	Value	Description
A	99"	Overall Length
B	39"	Overall Height
C	30"	Diameter
D	36"	Circulation
E	48"	Supports
F	26.38"	Support Width

## Options

- 150 PSI Vessel
- Hand Hole
- Optional Fittings / Additional Notes:

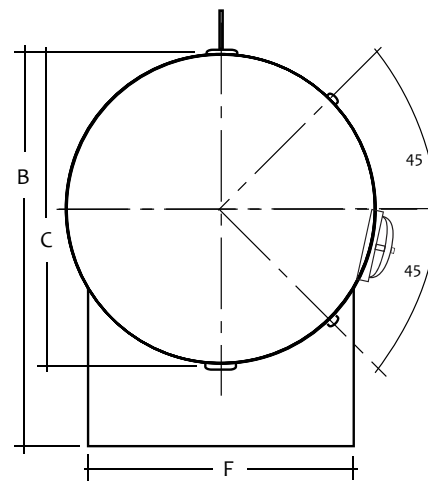
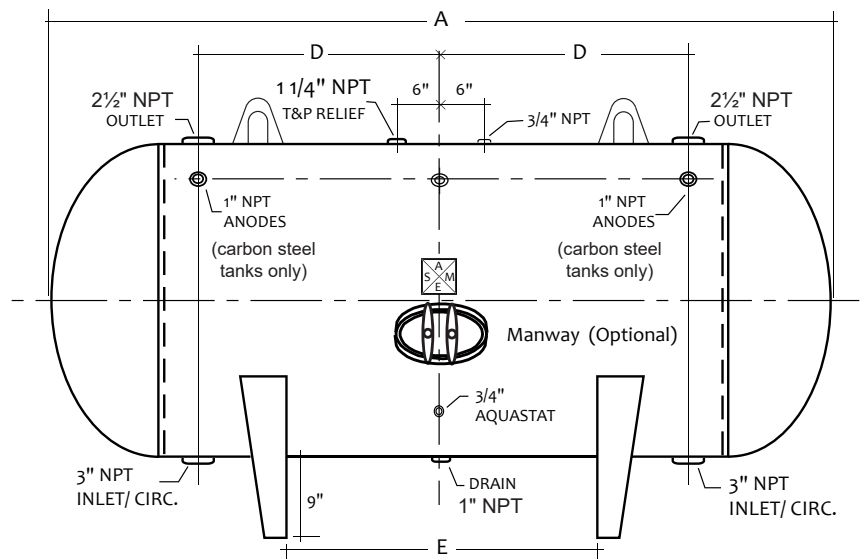

# Tank, Horizontal Bare

STHGB30111      STH2B30111  
 STHDB30111      STH3B30111  
 STHEB30111



## Design

- STHGB Carbon Steel, Glass Lined  
Primed Painted Exterior  
Five-Year Tank Limited Warranty
- STHDB Carbon Steel, Double-Glass Lined  
Primed Painted Exterior  
Ten-Year Tank Limited Warranty
- STHEB Carbon Steel, Epoxy Lining  
Primed Painted Exterior  
One-Year Tank Limited Warranty
- STH2B Duplex Stainless Steel  
Twenty-Five-Year\* Tank Limited Warranty  
\*See warranty sheet for details
- STH3B 316L Stainless Steel  
Ten-Year Tank Limited Warranty

## Submittal Data

Date:

Project #:

Engineer:

Project Name:

Prepared By:

Location:

Bid Date:

Contractor:

Code	ASME Sec IV HLW
Design Pressure	125 psi
Parts Warranty	One Year, Limited
Supports	Saddles
Capacity	320 Gallons
Nominal Capacity	340 Gallons
Weight	555 Lbs.

## Dimensions

Callout	Value	Description
A	111"	Overall Length
B	39"	Overall Height
C	30"	Diameter
D	42"	Circulation
E	60"	Supports
F	26.38"	Support Width

## Options

- 150 PSI Vessel
- Hand Hole
- Optional Fittings / Additional Notes:

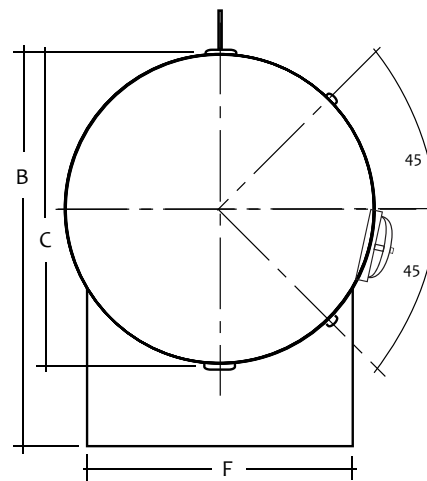
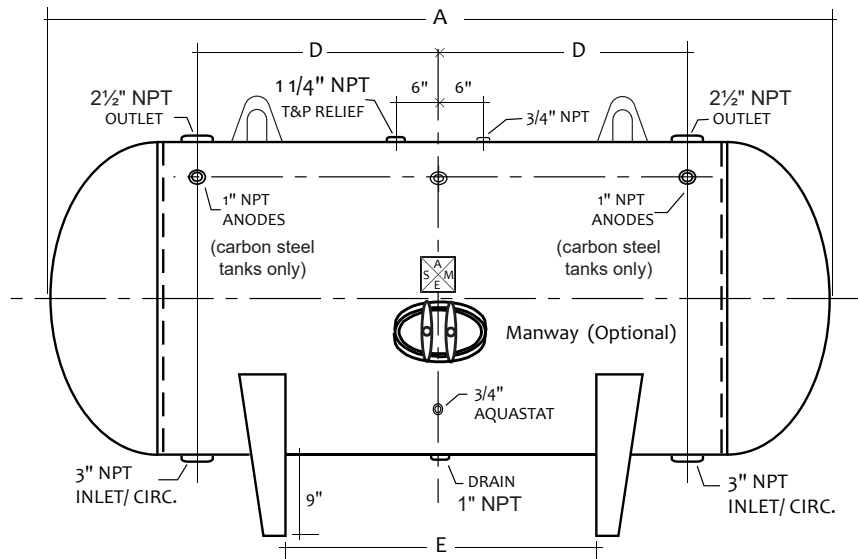

Customer Service and Product Support: 800.900.9276 • Fax 800.559.1583  
 Headquarters: 20 Industrial Way, Rochester, NH, USA 03867 • 603.335.6300 • Fax 603.335.3355  
 9 Brigden Gate, Halton Hills, Ontario, Canada L7G 0A3 • 905.203.0600 • Fax 905.636.0666

[www.Laars.com](http://www.Laars.com)

Litho in U.S.A. © Laars Heating Systems 20-09 Document 4223F

# Tank, Horizontal Bare

STHGB36072    STH2B36072  
 STHDB36072    STH3B36072  
 STHEB36072



## Design

- STHGB Carbon Steel, Glass Lined  
Primed Painted Exterior  
Five-Year Tank Limited Warranty
- STHDB Carbon Steel, Double-Glass Lined  
Primed Painted Exterior  
Ten-Year Tank Limited Warranty
- STHEB Carbon Steel, Epoxy Lining  
Primed Painted Exterior  
One-Year Tank Limited Warranty
- STH2B Duplex Stainless Steel  
Twenty-Five-Year\* Tank Limited Warranty  
\*See warranty sheet for details
- STH3B 316L Stainless Steel  
Ten-Year Tank Limited Warranty

## Submittal Data

Date:

Project #:

Engineer:

Project Name:

Prepared By:

Location:

Bid Date:

Contractor:

Code	ASME Sec IV HLW
Design Pressure	125 psi
Parts Warranty	One Year, Limited
Supports	Saddles
Capacity	285 Gallons
Nominal Capacity	318 Gallons
Weight	576 Lbs.

## Dimensions

Callout	Value	Description
A	72"	Overall Length
B	45"	Overall Height
C	36"	Diameter
D	21"	Circulation
E	18"	Supports
F	31.7"	Support Width

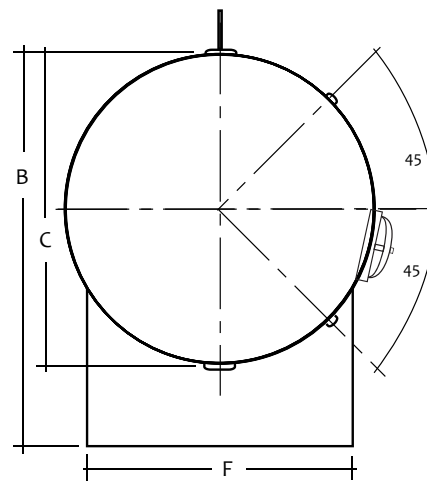
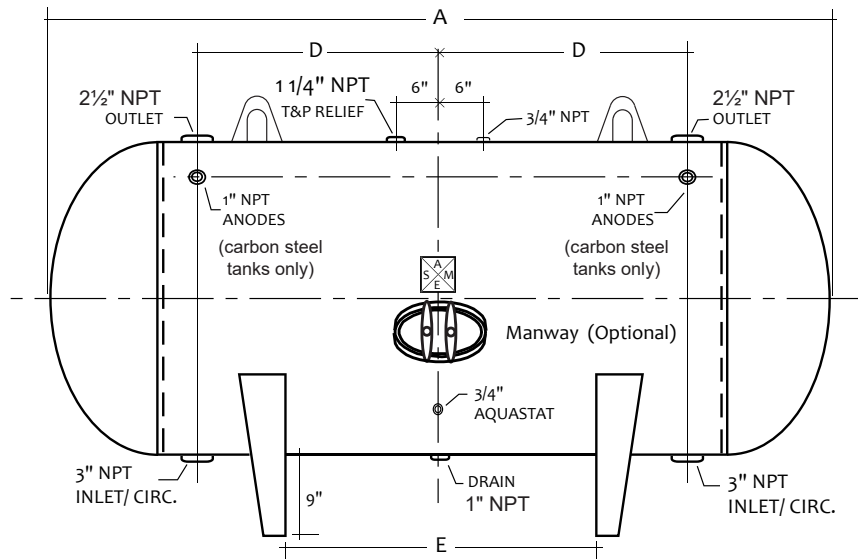

## Options

- 150 PSI Vessel
- Hand Hole
- Optional Fittings / Additional Notes:



Customer Service and Product Support: 800.900.9276 • Fax 800.559.1583  
 Headquarters: 20 Industrial Way, Rochester, NH, USA 03867 • 603.335.6300 • Fax 603.335.3355  
 9 Brigden Gate, Halton Hills, Ontario, Canada L7G 0A3 • 905.203.0600 • Fax 905.636.0666

[www.Laars.com](http://www.Laars.com)

Litho in U.S.A. © Laars Heating Systems 20-09 Document 4223F

# Tank, Horizontal Bare

STHGB36078    STH2B36078  
 STHDB36078    STH3B36078  
 STHEB36078



## Design

- STHGB Carbon Steel, Glass Lined  
Primed Painted Exterior  
Five-Year Tank Limited Warranty
- STHDB Carbon Steel, Double-Glass Lined  
Primed Painted Exterior  
Ten-Year Tank Limited Warranty
- STHEB Carbon Steel, Epoxy Lining  
Primed Painted Exterior  
One-Year Tank Limited Warranty
- STH2B Duplex Stainless Steel  
Twenty-Five-Year\* Tank Limited Warranty  
\*See warranty sheet for details
- STH3B 316L Stainless Steel  
Ten-Year Tank Limited Warranty

## Submittal Data

Date:

Project #:

Engineer:

Project Name:

Prepared By:

Location:

Bid Date:

Contractor:

Code	ASME Sec IV HLW
Design Pressure	125 psi
Parts Warranty	One Year, Limited
Supports	Saddles
Capacity	310 Gallons
Nominal Capacity	344 Gallons
Weight	614 Lbs.

## Dimensions

Callout	Value	Description
A	78"	Overall Length
B	45"	Overall Height
C	36"	Diameter
D	24"	Circulation
E	24"	Supports
F	31.7"	Support Width

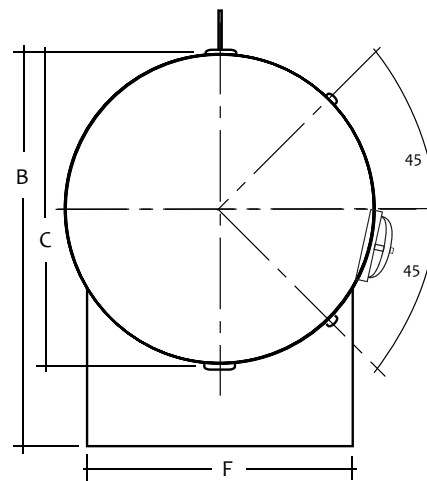
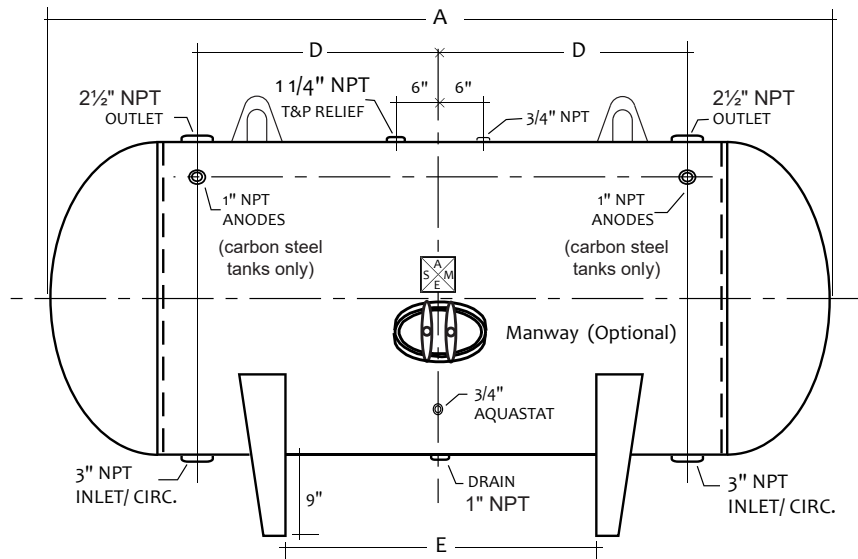

## Options

- 150 PSI Vessel
- Hand Hole
- Optional Fittings / Additional Notes:



Customer Service and Product Support: 800.900.9276 • Fax 800.559.1583  
 Headquarters: 20 Industrial Way, Rochester, NH, USA 03867 • 603.335.6300 • Fax 603.335.3355  
 9 Brigden Gate, Halton Hills, Ontario, Canada L7G 0A3 • 905.203.0600 • Fax 905.636.0666

[www.Laars.com](http://www.Laars.com)

Litho in U.S.A. © Laars Heating Systems 20-09 Document 4223F

# Tank, Horizontal Bare

STHGB36085    STH2B36085  
 STHDB36085    STH3B36085  
 STHEB36085



## Design

- STHGB Carbon Steel, Glass Lined  
Primed Painted Exterior  
Five-Year Tank Limited Warranty
- STHDB Carbon Steel, Double-Glass Lined  
Primed Painted Exterior  
Ten-Year Tank Limited Warranty
- STHEB Carbon Steel, Epoxy Lining  
Primed Painted Exterior  
One-Year Tank Limited Warranty
- STH2B Duplex Stainless Steel  
Twenty-Five-Year\* Tank Limited Warranty  
\*See warranty sheet for details
- STH3B 316L Stainless Steel  
Ten-Year Tank Limited Warranty

## Submittal Data

Date:

Project #:

Engineer:

Project Name:

Prepared By:

Location:

Bid Date:

Contractor:

Code	ASME Sec IV HLW
Design Pressure	125 psi
Parts Warranty	One Year, Limited
Supports	Saddles
Capacity	340 Gallons
Nominal Capacity	375 Gallons
Weight	659 Lbs.

## Dimensions

Callout	Value	Description
A	85"	Overall Length
B	45"	Overall Height
C	36"	Diameter
D	27.5"	Circulation
E	31"	Supports
F	31.7"	Support Width

## Options

- 150 PSI Vessel
- Hand Hole
- Optional Fittings / Additional Notes:

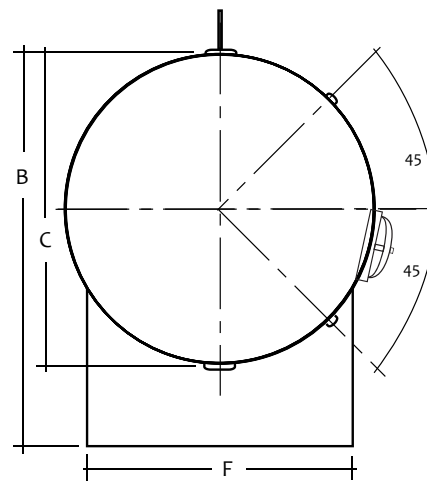
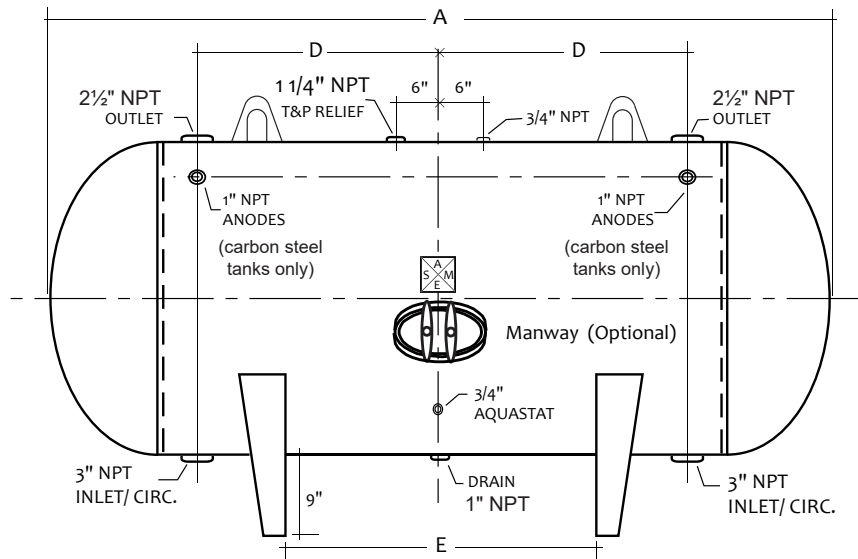

Customer Service and Product Support: 800.900.9276 • Fax 800.559.1583  
 Headquarters: 20 Industrial Way, Rochester, NH, USA 03867 • 603.335.6300 • Fax 603.335.3355  
 9 Brigden Gate, Halton Hills, Ontario, Canada L7G 0A3 • 905.203.0600 • Fax 905.636.0666

[www.Laars.com](http://www.Laars.com)

Litho in U.S.A. © Laars Heating Systems 20-09 Document 4223F



# Tank, Horizontal Bare

STHGB36090    STH2B36090  
 STHDB36090    STH3B36090  
 STHEB36090



## Design

- STHGB Carbon Steel, Glass Lined  
Primed Painted Exterior  
Five-Year Tank Limited Warranty
- STHDB Carbon Steel, Double-Glass Lined  
Primed Painted Exterior  
Ten-Year Tank Limited Warranty
- STHEB Carbon Steel, Epoxy Lining  
Primed Painted Exterior  
One-Year Tank Limited Warranty
- STH2B Duplex Stainless Steel  
Twenty-Five-Year\* Tank Limited Warranty  
\*See warranty sheet for details
- STH3B 316L Stainless Steel  
Ten-Year Tank Limited Warranty

## Submittal Data

Date:

Project #:

Engineer:

Project Name:

Prepared By:

Location:

Bid Date:

Contractor:

Code	ASME Sec IV HLW
Design Pressure	125 psi
Parts Warranty	One Year, Limited
Supports	Saddles
Capacity	360 Gallons
Nominal Capacity	397 Gallons
Weight	690 Lbs.

## Dimensions

Callout	Value	Description
A	90"	Overall Length
B	45"	Overall Height
C	36"	Diameter
D	30"	Circulation
E	36"	Supports
F	31.7"	Support Width

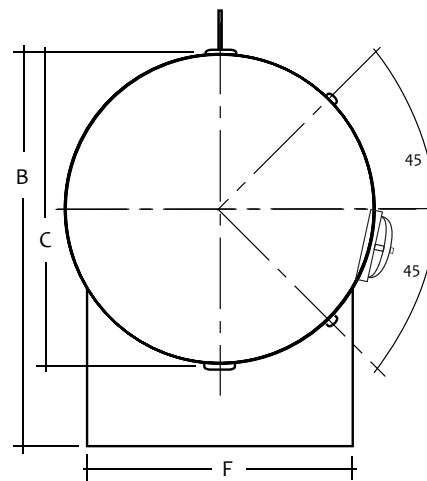
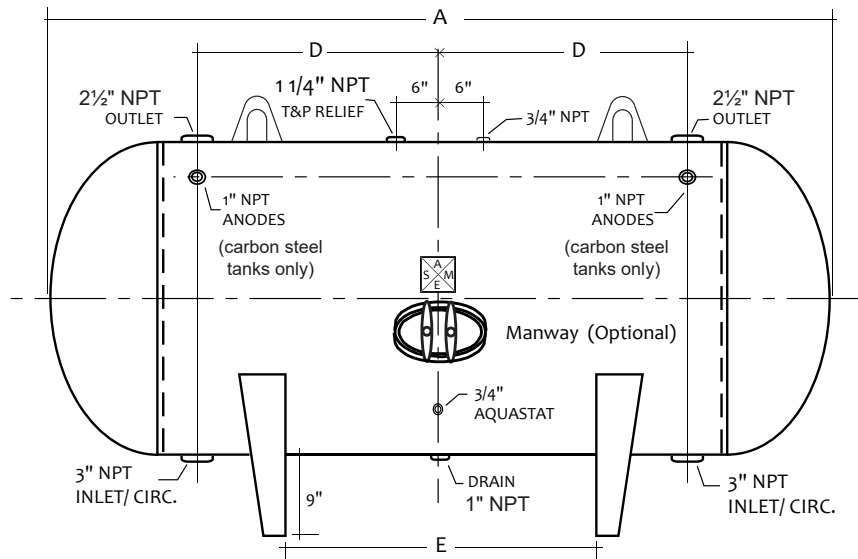

## Options

- 150 PSI Vessel
- Hand Hole
- Optional Fittings / Additional Notes:



Customer Service and Product Support: 800.900.9276 • Fax 800.559.1583  
 Headquarters: 20 Industrial Way, Rochester, NH, USA 03867 • 603.335.6300 • Fax 603.335.3355  
 9 Brigden Gate, Halton Hills, Ontario, Canada L7G 0A3 • 905.203.0600 • Fax 905.636.0666

www.Laars.com

Litho in U.S.A. © Laars Heating Systems 20-09 Document 4223F

# Tank, Horizontal Bare

STHGB36102    STH2B36102  
 STHDB36102    STH3B36102  
 STHEB36102



## Design

- STHGB Carbon Steel, Glass Lined  
Primed Painted Exterior  
Five-Year Tank Limited Warranty
- STHDB Carbon Steel, Double-Glass Lined  
Primed Painted Exterior  
Ten-Year Tank Limited Warranty
- STHEB Carbon Steel, Epoxy Lining  
Primed Painted Exterior  
One-Year Tank Limited Warranty
- STH2B Duplex Stainless Steel  
Twenty-Five-Year\* Tank Limited Warranty  
\*See warranty sheet for details
- STH3B 316L Stainless Steel  
Ten-Year Tank Limited Warranty

## Submittal Data

Date:

Project #:

Engineer:

Project Name:

Prepared By:

Location:

Bid Date:

Contractor:

Code	ASME Sec IV HLW
Design Pressure	125 psi
Parts Warranty	One Year, Limited
Supports	Saddles
Capacity	415 Gallons
Nominal Capacity	449 Gallons
Weight	768 Lbs.

## Dimensions

Callout	Value	Description
A	102"	Overall Length
B	45"	Overall Height
C	36"	Diameter
D	36"	Circulation
E	48"	Supports
F	31.7"	Support Width

## Options

- 150 PSI Vessel
- Hand Hole
- Optional Fittings / Additional Notes:

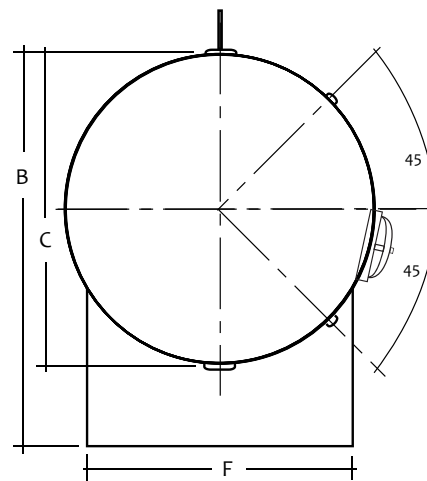
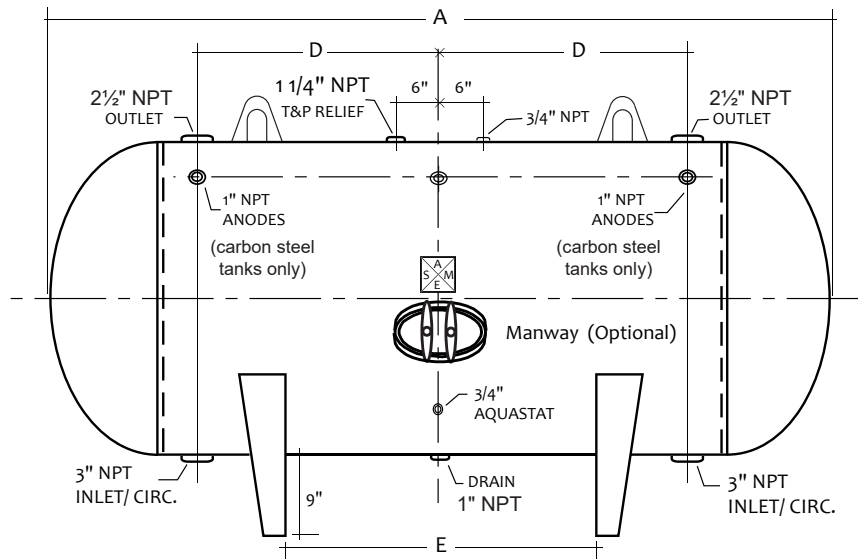

# Tank, Horizontal Bare

STHGB36114    STH2B36114  
 STHDB36114    STH3B36114  
 STHEB36114



## Design

- STHGB Carbon Steel, Glass Lined  
Primed Painted Exterior  
Five-Year Tank Limited Warranty
- STHDB Carbon Steel, Double-Glass Lined  
Primed Painted Exterior  
Ten-Year Tank Limited Warranty
- STHEB Carbon Steel, Epoxy Lining  
Primed Painted Exterior  
One-Year Tank Limited Warranty
- STH2B Duplex Stainless Steel  
Twenty-Five-Year\* Tank Limited Warranty  
\*See warranty sheet for details
- STH3B 316L Stainless Steel  
Ten-Year Tank Limited Warranty

## Submittal Data

Date:

Project #:

Engineer:

Project Name:

Prepared By:

Location:

Bid Date:

Contractor:

Code	ASME Sec IV HLW
Design Pressure	125 psi
Parts Warranty	One Year, Limited
Supports	Saddles
Capacity	465 Gallons
Nominal Capacity	502 Gallons
Weight	884 Lbs.

## Dimensions

Callout	Value	Description
A	114"	Overall Length
B	45"	Overall Height
C	36"	Diameter
D	42"	Circulation
E	60"	Supports
F	31.7"	Support Width

## Options

- 150 PSI Vessel
- Hand Hole
- Optional Fittings / Additional Notes:

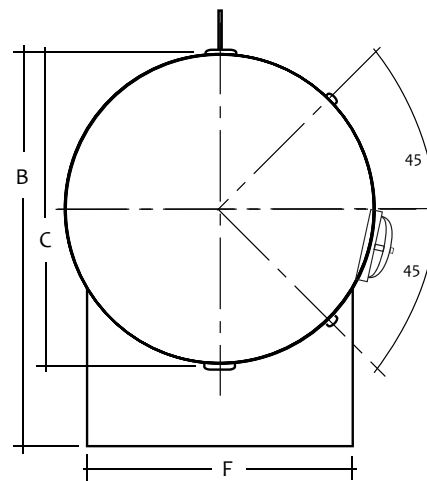
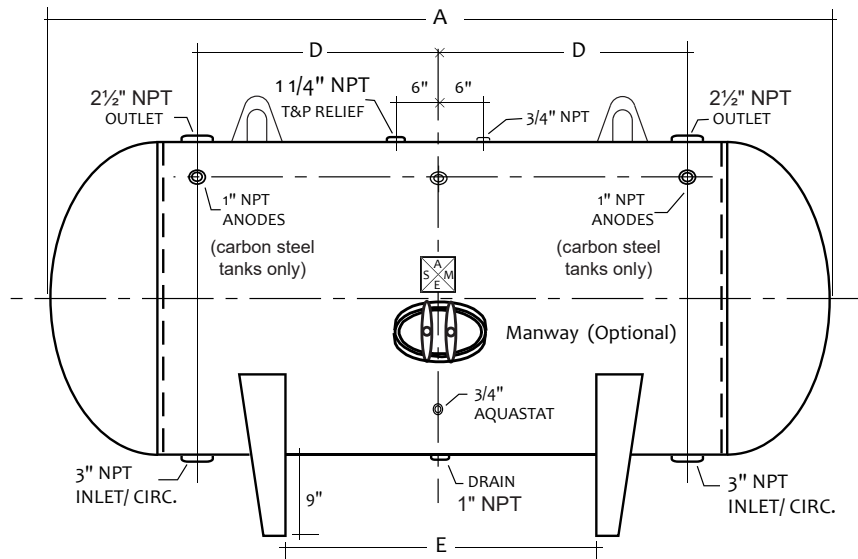

Customer Service and Product Support: 800.900.9276 • Fax 800.559.1583  
 Headquarters: 20 Industrial Way, Rochester, NH, USA 03867 • 603.335.6300 • Fax 603.335.3355  
 9 Brigden Gate, Halton Hills, Ontario, Canada L7G 0A3 • 905.203.0600 • Fax 905.636.0666

[www.Laars.com](http://www.Laars.com)

Litho in U.S.A. © Laars Heating Systems 20-09 Document 4223F

# Tank, Horizontal Bare

STHGB36126    STH2B36126  
 STHDB36126    STH3B36126  
 STHEB36126



## Design

- STHGB Carbon Steel, Glass Lined  
Primed Painted Exterior  
Five-Year Tank Limited Warranty
- STHDB Carbon Steel, Double-Glass Lined  
Primed Painted Exterior  
Ten-Year Tank Limited Warranty
- STHEB Carbon Steel, Epoxy Lining  
Primed Painted Exterior  
One-Year Tank Limited Warranty
- STH2B Duplex Stainless Steel  
Twenty-Five-Year\* Tank Limited Warranty  
\*See warranty sheet for details
- STH3B 316L Stainless Steel  
Ten-Year Tank Limited Warranty

## Submittal Data

Date:

Project #:

Engineer:

Project Name:

Prepared By:

Location:

Bid Date:

Contractor:

Code	ASME Sec IV HLW
Design Pressure	125 psi
Parts Warranty	One Year, Limited
Supports	Saddles
Capacity	515 Gallons
Nominal Capacity	555 Gallons
Weight	920 Lbs.

## Dimensions

Callout	Value	Description
A	126"	Overall Length
B	45"	Overall Height
C	36"	Diameter
D	48"	Circulation
E	72"	Supports
F	31.7"	Support Width

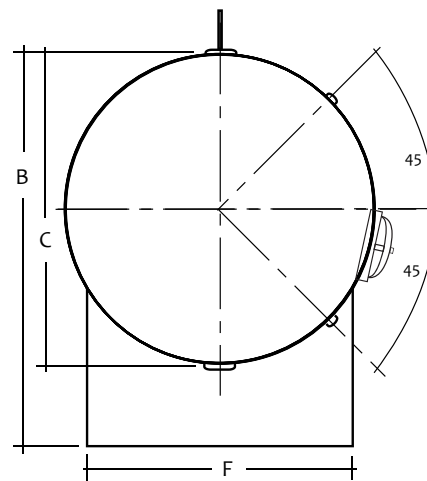
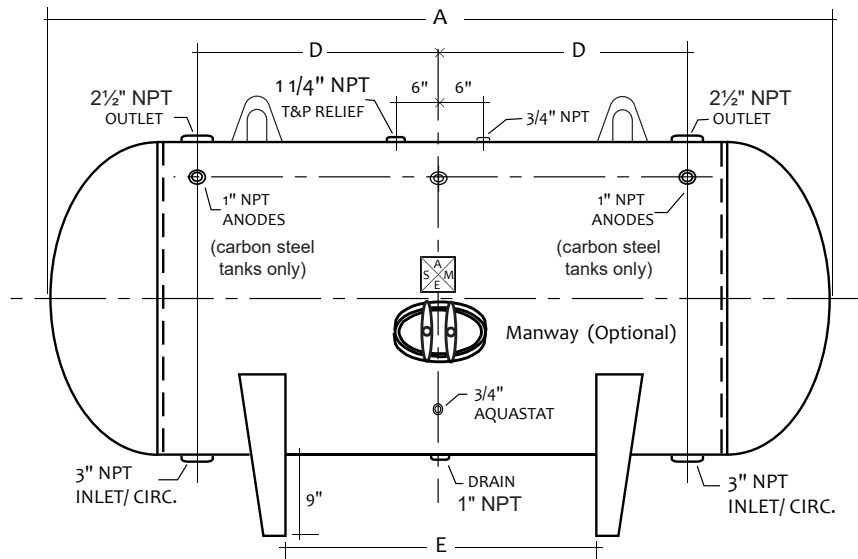

## Options

- 150 PSI Vessel
- Hand Hole
- Optional Fittings / Additional Notes:



Customer Service and Product Support: 800.900.9276 • Fax 800.559.1583  
 Headquarters: 20 Industrial Way, Rochester, NH, USA 03867 • 603.335.6300 • Fax 603.335.3355  
 9 Brigden Gate, Halton Hills, Ontario, Canada L7G 0A3 • 905.203.0600 • Fax 905.636.0666

[www.Laars.com](http://www.Laars.com)

Litho in U.S.A. © Laars Heating Systems 20-09 Document 4223F

# Tank, Horizontal Bare

STHGB42081    STH2B42081  
 STHDB42081    STH3B42081  
 STHEB42081



## Design

- STHGB Carbon Steel, Glass Lined  
Primed Painted Exterior  
Five-Year Tank Limited Warranty
- STHDB Carbon Steel, Double-Glass Lined  
Primed Painted Exterior  
Ten-Year Tank Limited Warranty
- STHEB Carbon Steel, Epoxy Lining  
Primed Painted Exterior  
One-Year Tank Limited Warranty
- STH2B Duplex Stainless Steel  
Twenty-Five-Year\* Tank Limited Warranty  
\*See warranty sheet for details
- STH3B 316L Stainless Steel  
Ten-Year Tank Limited Warranty

## Submittal Data

Date:

Project #:

Engineer:

Project Name:

Prepared By:

Location:

Bid Date:

Contractor:

Code	ASME Sec IV HLW
Design Pressure	125 psi
Parts Warranty	One Year, Limited
Supports	Saddles
Capacity	435 Gallons
Nominal Capacity	486 Gallons
Weight	810 Lbs.

## Dimensions

Callout	Value	Description
A	81"	Overall Length
B	51"	Overall Height
C	42"	Diameter
D	24"	Circulation
E	24"	Supports
F	36.8"	Support Width

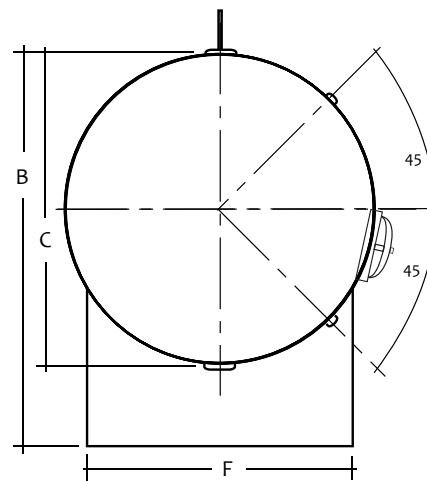
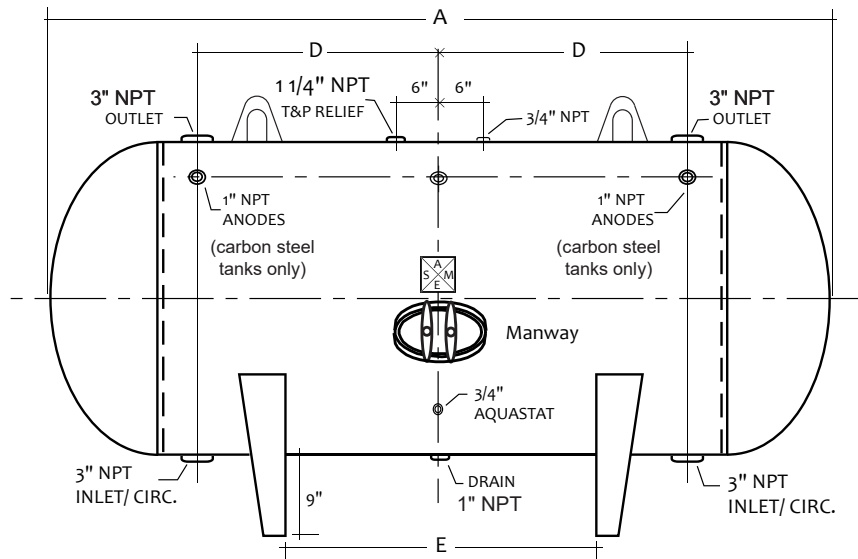

## Options

- 150 PSI Vessel
- Hand Hole
- Optional Fittings / Additional Notes:



Customer Service and Product Support: 800.900.9276 • Fax 800.559.1583  
 Headquarters: 20 Industrial Way, Rochester, NH, USA 03867 • 603.335.6300 • Fax 603.335.3355  
 9 Brigden Gate, Halton Hills, Ontario, Canada L7G 0A3 • 905.203.0600 • Fax 905.636.0666

[www.Laars.com](http://www.Laars.com)

Litho in U.S.A. © Laars Heating Systems 20-09 Document 4223F

# Tank, Horizontal Bare

STHGB42084    STH2B42084  
 STHDB42084    STH3B42084  
 STHEB42084



## Design

- STHGB Carbon Steel, Glass Lined  
Primed Painted Exterior  
Five-Year Tank Limited Warranty
- STHDB Carbon Steel, Double-Glass Lined  
Primed Painted Exterior  
Ten-Year Tank Limited Warranty
- STHEB Carbon Steel, Epoxy Lining  
Primed Painted Exterior  
One-Year Tank Limited Warranty
- STH2B Duplex Stainless Steel  
Twenty-Five-Year\* Tank Limited Warranty  
\*See warranty sheet for details
- STH3B 316L Stainless Steel  
Ten-Year Tank Limited Warranty

Date:

Project #:

Engineer:

Prepared By:

Bid Date:

## Submittal Data

Project Name:

Location:

Contractor:

Code	ASME Sec IV HLW
Design Pressure	125 psi
Parts Warranty	One Year, Limited
Supports	Saddles
Capacity	453 Gallons
Nominal Capacity	504 Gallons
Weight	832 Lbs.

## Dimensions

Callout	Value	Description
A	84"	Overall Length
B	51"	Overall Height
C	42"	Diameter
D	25.5"	Circulation
E	27"	Supports
F	36.8"	Support Width

## Options

- 150 PSI Vessel
- Hand Hole
- Optional Fittings / Additional Notes:

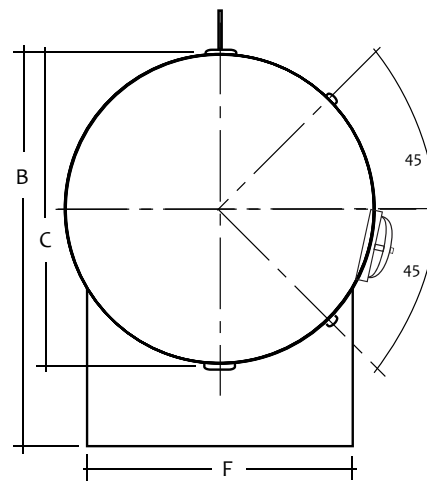
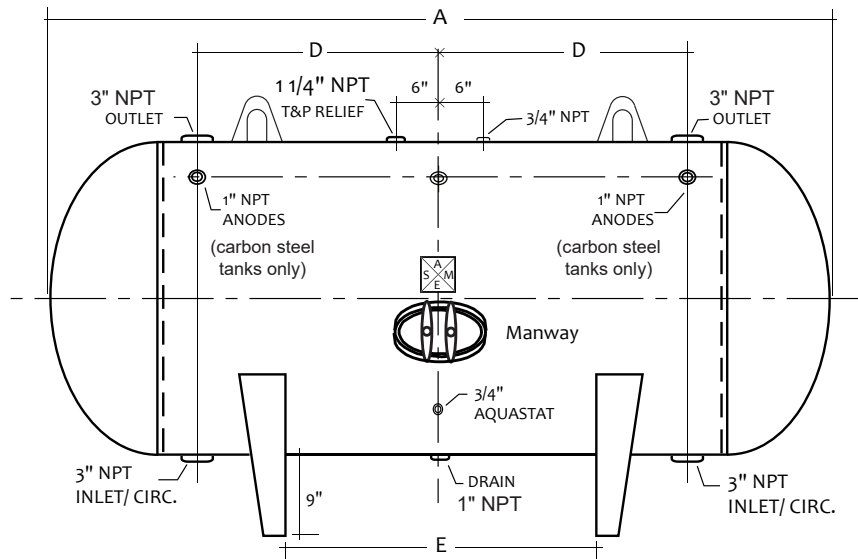

Customer Service and Product Support: 800.900.9276 • Fax 800.559.1583  
 Headquarters: 20 Industrial Way, Rochester, NH, USA 03867 • 603.335.6300 • Fax 603.335.3355  
 9 Brigden Gate, Halton Hills, Ontario, Canada L7G 0A3 • 905.203.0600 • Fax 905.636.0666  
[www.Laars.com](http://www.Laars.com)      Litho in U.S.A. © Laars Heating Systems 20-09 Document 4223F

# Tank, Horizontal Bare

STHGB42093    STH2B42093  
 STHDB42093    STH3B42093  
 STHEB42093



## Design

- STHGB Carbon Steel, Glass Lined  
Primed Painted Exterior  
Five-Year Tank Limited Warranty
- STHDB Carbon Steel, Double-Glass Lined  
Primed Painted Exterior  
Ten-Year Tank Limited Warranty
- STHEB Carbon Steel, Epoxy Lining  
Primed Painted Exterior  
One-Year Tank Limited Warranty
- STH2B Duplex Stainless Steel  
Twenty-Five-Year\* Tank Limited Warranty  
\*See warranty sheet for details
- STH3B 316L Stainless Steel  
Ten-Year Tank Limited Warranty

## Submittal Data

Date:

Project #:

Engineer:

Project Name:

Prepared By:

Location:

Bid Date:

Contractor:

Code	ASME Sec IV HLW
Design Pressure	125 psi
Parts Warranty	One Year, Limited
Supports	Saddles
Capacity	505 Gallons
Nominal Capacity	558 Gallons
Weight	874 Lbs.

## Dimensions

Callout	Value	Description
A	93"	Overall Length
B	51"	Overall Height
C	42"	Diameter
D	30"	Circulation
E	36"	Supports
F	36.8"	Support Width

## Options

- 150 PSI Vessel
- Hand Hole
- Optional Fittings / Additional Notes:

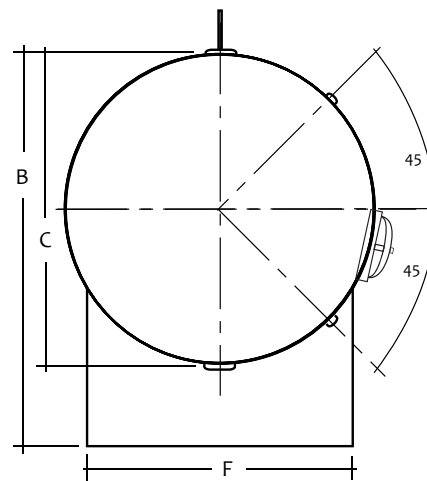
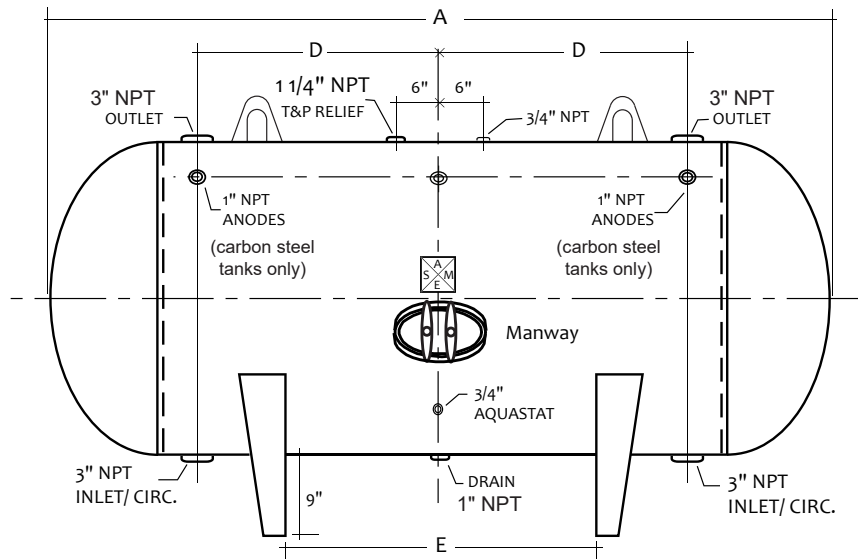

Customer Service and Product Support: 800.900.9276 • Fax 800.559.1583  
 Headquarters: 20 Industrial Way, Rochester, NH, USA 03867 • 603.335.6300 • Fax 603.335.3355  
 9 Brigden Gate, Halton Hills, Ontario, Canada L7G 0A3 • 905.203.0600 • Fax 905.636.0666

[www.Laars.com](http://www.Laars.com)

Litho in U.S.A. © Laars Heating Systems 20-09 Document 4223F

# Tank, Horizontal Bare

STHGB42105    STH2B42105  
 STHDB42105    STH3B42105  
 STHEB42105



## Design

- STHGB Carbon Steel, Glass Lined  
Primed Painted Exterior  
Five-Year Tank Limited Warranty
- STHDB Carbon Steel, Double-Glass Lined  
Primed Painted Exterior  
Ten-Year Tank Limited Warranty
- STHEB Carbon Steel, Epoxy Lining  
Primed Painted Exterior  
One-Year Tank Limited Warranty
- STH2B Duplex Stainless Steel  
Twenty-Five-Year\* Tank Limited Warranty  
\*See warranty sheet for details
- STH3B 316L Stainless Steel  
Ten-Year Tank Limited Warranty

## Submittal Data

Date:

Project #:

Engineer:

Project Name:

Prepared By:

Location:

Bid Date:

Contractor:

Code	ASME Sec IV HLW
Design Pressure	125 psi
Parts Warranty	One Year, Limited
Supports	Saddles
Capacity	575 Gallons
Nominal Capacity	630 Gallons
Weight	900 Lbs.

## Dimensions

Callout	Value	Description
A	105"	Overall Length
B	51"	Overall Height
C	42"	Diameter
D	36"	Circulation
E	48"	Supports
F	36.8"	Support Width

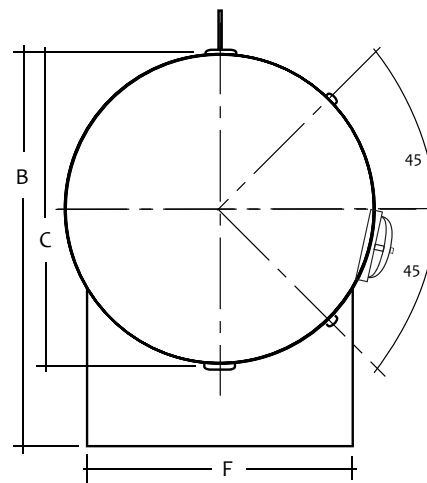
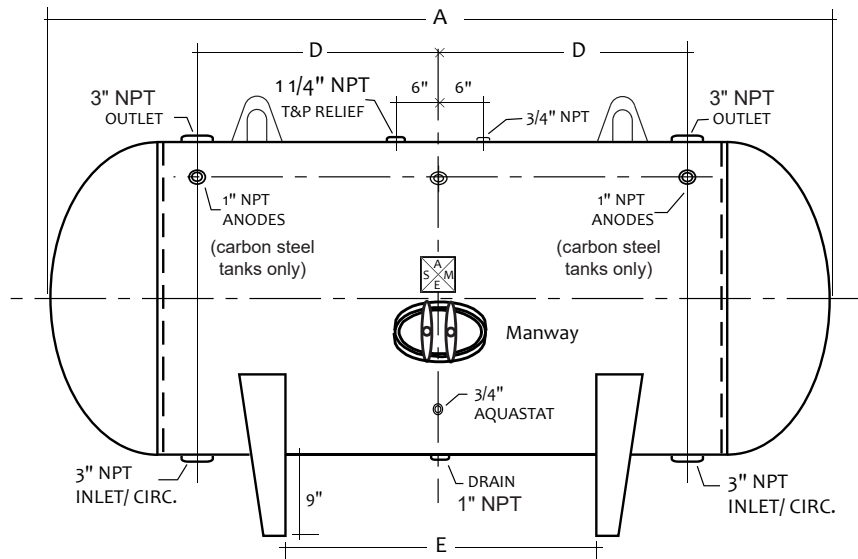

## Options

- 150 PSI Vessel
- Hand Hole
- Optional Fittings / Additional Notes:



Customer Service and Product Support: 800.900.9276 • Fax 800.559.1583  
 Headquarters: 20 Industrial Way, Rochester, NH, USA 03867 • 603.335.6300 • Fax 603.335.3355  
 9 Brigden Gate, Halton Hills, Ontario, Canada L7G 0A3 • 905.203.0600 • Fax 905.636.0666

[www.Laars.com](http://www.Laars.com)

Litho in U.S.A. © Laars Heating Systems 20-09 Document 4223F



# Tank, Horizontal Bare

STHGB42117    STH2B42117  
 STHDB42117    STH3B42117  
 STHEB42117



## Design

- STHGB Carbon Steel, Glass Lined  
Primed Painted Exterior  
Five-Year Tank Limited Warranty
- STHDB Carbon Steel, Double-Glass Lined  
Primed Painted Exterior  
Ten-Year Tank Limited Warranty
- STHEB Carbon Steel, Epoxy Lining  
Primed Painted Exterior  
One-Year Tank Limited Warranty
- STH2B Duplex Stainless Steel  
Twenty-Five-Year\* Tank Limited Warranty  
\*See warranty sheet for details
- STH3B 316L Stainless Steel  
Ten-Year Tank Limited Warranty

## Submittal Data

Date:

Project #:

Engineer:

Project Name:

Prepared By:

Location:

Bid Date:

Contractor:

Code	ASME Sec IV HLW
Design Pressure	125 psi
Parts Warranty	One Year, Limited
Supports	Saddles
Capacity	645 Gallons
Nominal Capacity	702 Gallons
Weight	984 Lbs.

## Dimensions

Callout	Value	Description
A	117"	Overall Length
B	51"	Overall Height
C	42"	Diameter
D	42"	Circulation
E	60"	Supports
F	36.8"	Support Width

## Options

- 150 PSI Vessel
- Hand Hole
- Optional Fittings / Additional Notes:

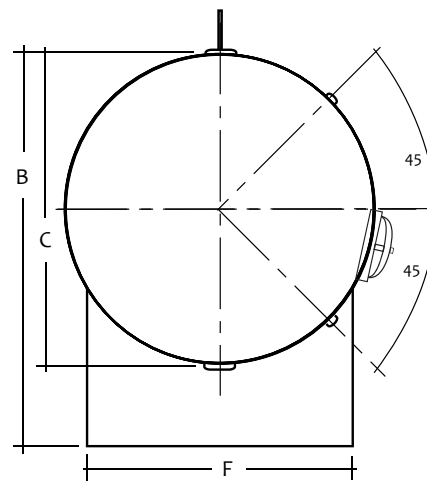
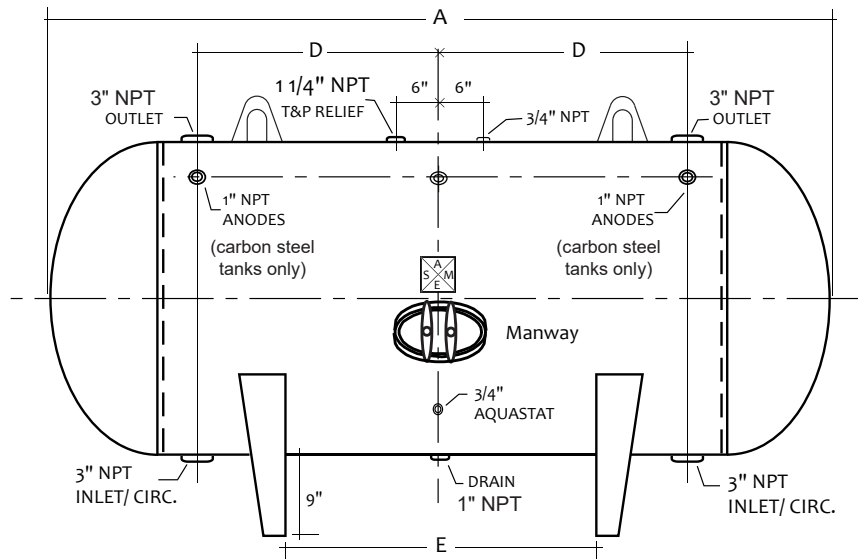

Customer Service and Product Support: 800.900.9276 • Fax 800.559.1583  
 Headquarters: 20 Industrial Way, Rochester, NH, USA 03867 • 603.335.6300 • Fax 603.335.3355  
 9 Brigden Gate, Halton Hills, Ontario, Canada L7G 0A3 • 905.203.0600 • Fax 905.636.0666

[www.Laars.com](http://www.Laars.com)

Litho in U.S.A. © Laars Heating Systems 20-09 Document 4223F

# Tank, Horizontal Bare

STHGB42129    STH2B42129  
 STHDB42129    STH3B42129  
 STHEB42129



## Design

- STHGB Carbon Steel, Glass Lined  
Primed Painted Exterior  
Five-Year Tank Limited Warranty
- STHDB Carbon Steel, Double-Glass Lined  
Primed Painted Exterior  
Ten-Year Tank Limited Warranty
- STHEB Carbon Steel, Epoxy Lining  
Primed Painted Exterior  
One-Year Tank Limited Warranty
- STH2B Duplex Stainless Steel  
Twenty-Five-Year\* Tank Limited Warranty  
\*See warranty sheet for details
- STH3B 316L Stainless Steel  
Ten-Year Tank Limited Warranty

## Submittal Data

Date:

Project #:

Engineer:

Project Name:

Prepared By:

Location:

Bid Date:

Contractor:

Code	ASME Sec IV HLW
Design Pressure	125 psi
Parts Warranty	One Year, Limited
Supports	Saddles
Capacity	720 Gallons
Nominal Capacity	774 Gallons
Weight	1068 Lbs.

## Dimensions

Callout	Value	Description
A	129"	Overall Length
B	51"	Overall Height
C	42"	Diameter
D	48"	Circulation
E	72"	Supports
F	36.8"	Support Width

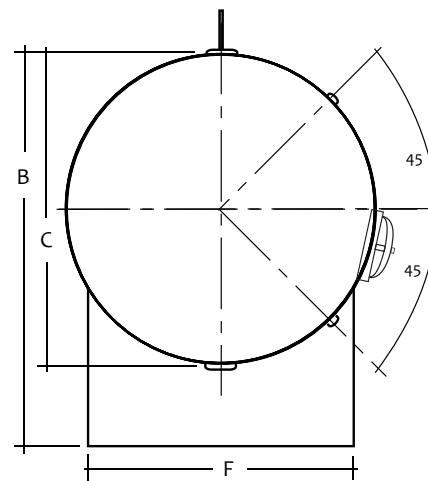
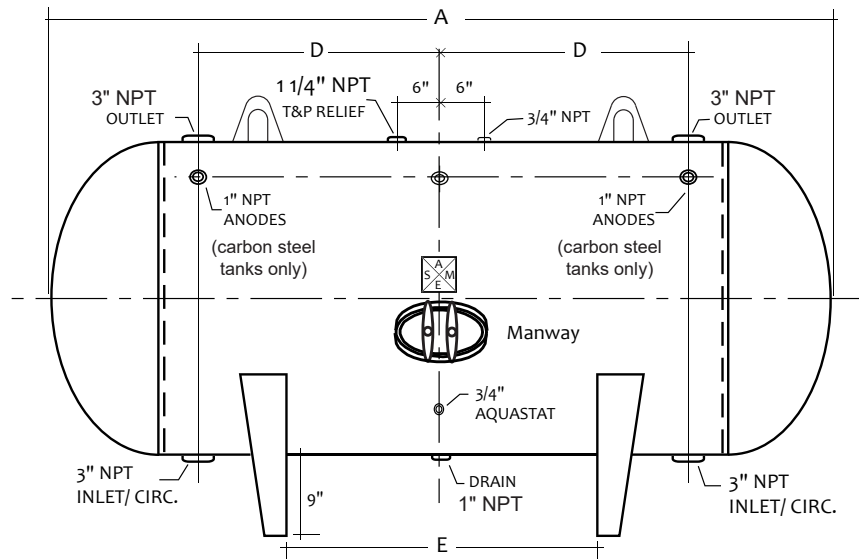

## Options

- 150 PSI Vessel
- Hand Hole
- Optional Fittings / Additional Notes:

# Tank, Horizontal Bare

STHGB42139    STH2B42139  
 STHDB42139    STH3B42139  
 STHEB42139



## Design

- STHGB Carbon Steel, Glass Lined  
Primed Painted Exterior  
Five-Year Tank Limited Warranty
- STHDB Carbon Steel, Double-Glass Lined  
Primed Painted Exterior  
Ten-Year Tank Limited Warranty
- STHEB Carbon Steel, Epoxy Lining  
Primed Painted Exterior  
One-Year Tank Limited Warranty
- STH2B Duplex Stainless Steel  
Twenty-Five-Year\* Tank Limited Warranty  
\*See warranty sheet for details
- STH3B 316L Stainless Steel  
Ten-Year Tank Limited Warranty

## Submittal Data

Date:

Project #:

Engineer:

Project Name:

Prepared By:

Location:

Bid Date:

Contractor:

Code	ASME Sec IV HLW
Design Pressure	125 psi
Parts Warranty	One Year, Limited
Supports	Saddles
Capacity	776 Gallons
Nominal Capacity	834 Gallons
Weight	1138 Lbs.

## Dimensions

Callout	Value	Description
A	139"	Overall Length
B	51"	Overall Height
C	42"	Diameter
D	53"	Circulation
E	82"	Supports
F	36.8"	Support Width

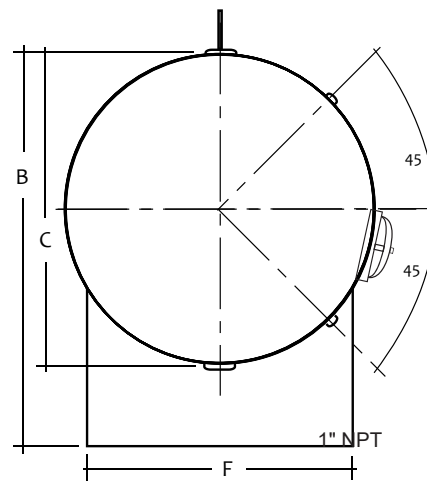
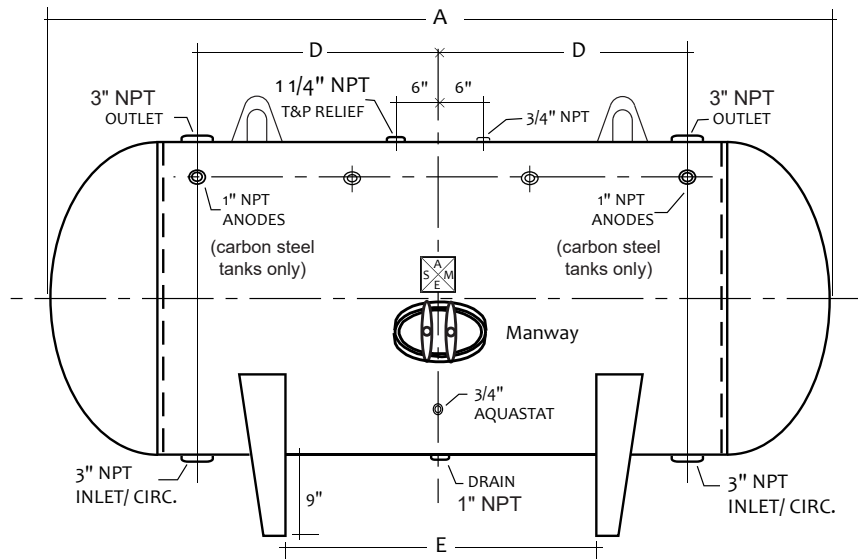

## Options

- 150 PSI Vessel
- Hand Hole
- Optional Fittings / Additional Notes:



Customer Service and Product Support: 800.900.9276 • Fax 800.559.1583  
 Headquarters: 20 Industrial Way, Rochester, NH, USA 03867 • 603.335.6300 • Fax 603.335.3355  
 9 Brigden Gate, Halton Hills, Ontario, Canada L7G 0A3 • 905.203.0600 • Fax 905.636.0666  
[www.Laars.com](http://www.Laars.com)    Litho in U.S.A. © Laars Heating Systems 20-09 Document 4223F

# Tank, Horizontal Bare

STHGB48073    STH2B48073  
 STHDB48073    STH3B48073  
 STHEB48073



## Design

- STHGB Carbon Steel, Glass Lined  
Primed Painted Exterior  
Five-Year Tank Limited Warranty
- STHDB Carbon Steel, Double-Glass Lined  
Primed Painted Exterior  
Ten-Year Tank Limited Warranty
- STHEB Carbon Steel, Epoxy Lining  
Primed Painted Exterior  
One-Year Tank Limited Warranty
- STH2B Duplex Stainless Steel  
Twenty-Five-Year\* Tank Limited Warranty  
\*See warranty sheet for details
- STH3B 316L Stainless Steel  
Ten-Year Tank Limited Warranty

## Submittal Data

Date:

Project #:

Engineer:

Project Name:

Prepared By:

Location:

Bid Date:

Contractor:

Code	ASME Sec IV HLW
Design Pressure	125 psi
Parts Warranty	One Year, Limited
Supports	Saddles
Capacity	500 Gallons
Nominal Capacity	572 Gallons
Weight	1090 Lbs.

## Dimensions

Callout	Value	Description
A	73"	Overall Length
B	57"	Overall Height
C	48"	Diameter
D	18.5"	Circulation
E	17"	Supports
F	42.1"	Support Width

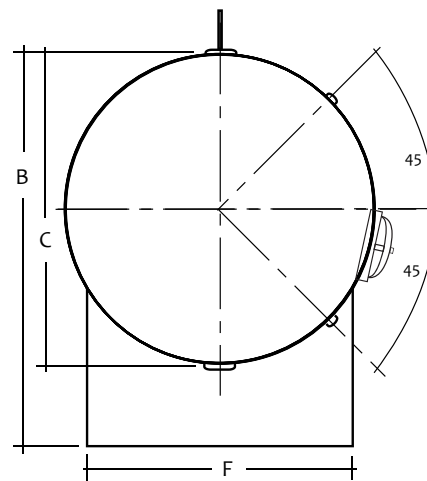
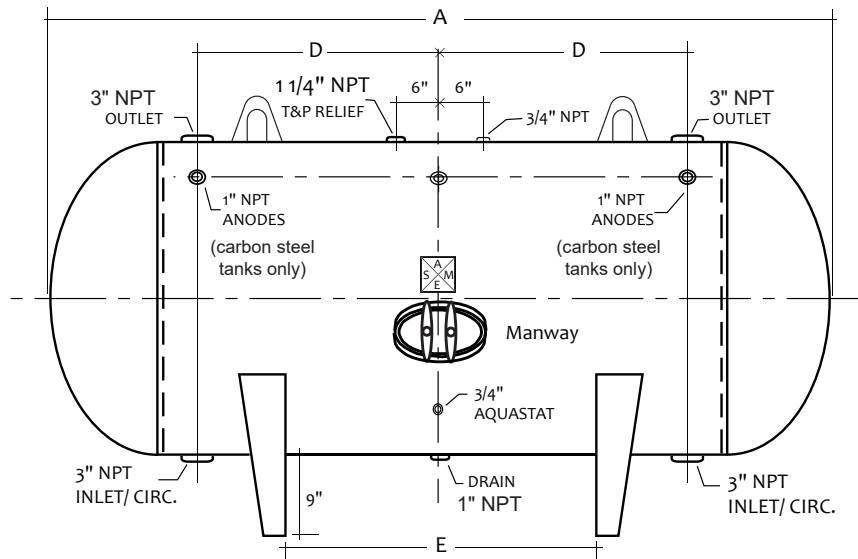

## Options

- 150 PSI Vessel
- Hand Hole
- Optional Fittings / Additional Notes:



Customer Service and Product Support: 800.900.9276 • Fax 800.559.1583  
 Headquarters: 20 Industrial Way, Rochester, NH, USA 03867 • 603.335.6300 • Fax 603.335.3355  
 9 Brigden Gate, Halton Hills, Ontario, Canada L7G 0A3 • 905.203.0600 • Fax 905.636.0666

[www.Laars.com](http://www.Laars.com)

Litho in U.S.A. © Laars Heating Systems 20-09 Document 4223F

# Tank, Horizontal Bare

STHGB48084    STH2B48084  
 STHDB48084    STH3B48084  
 STHEB48084



## Design

- STHGB Carbon Steel, Glass Lined  
Primed Painted Exterior  
Five-Year Tank Limited Warranty
- STHDB Carbon Steel, Double-Glass Lined  
Primed Painted Exterior  
Ten-Year Tank Limited Warranty
- STHEB Carbon Steel, Epoxy Lining  
Primed Painted Exterior  
One-Year Tank Limited Warranty
- STH2B Duplex Stainless Steel  
Twenty-Five-Year\* Tank Limited Warranty  
\*See warranty sheet for details
- STH3B 316L Stainless Steel  
Ten-Year Tank Limited Warranty

Date:

Project #:

Engineer:

Prepared By:

Bid Date:

## Submittal Data

Project Name:

Location:

Contractor:

Code	ASME Sec IV HLW
Design Pressure	125 psi
Parts Warranty	One Year, Limited
Supports	Saddles
Capacity	580 Gallons
Nominal Capacity	658 Gallons
Weight	1213 Lbs.

## Dimensions

Callout	Value	Description
A	84"	Overall Length
B	57"	Overall Height
C	48"	Diameter
D	24"	Circulation
E	24"	Supports
F	42.1"	Support Width

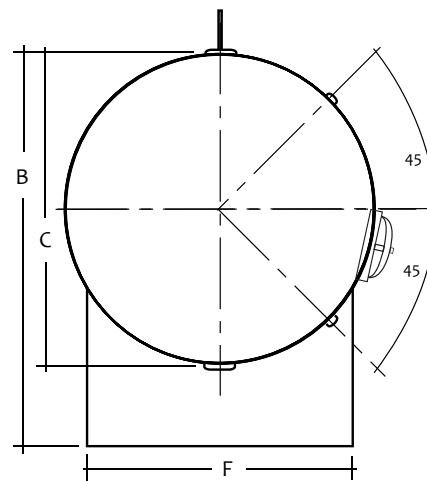
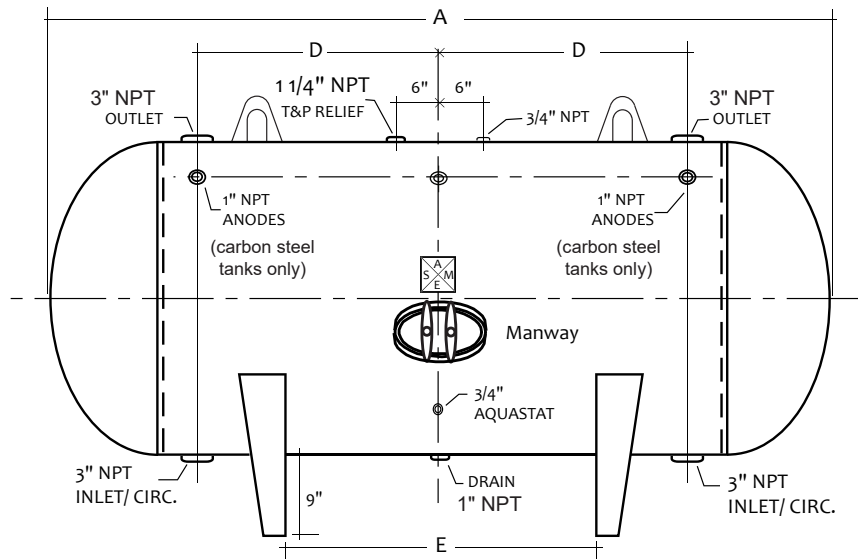

## Options

- 150 PSI Vessel
- Hand Hole
- Optional Fittings / Additional Notes:



**Customer Service and Product Support: 800.900.9276 • Fax 800.559.1583**  
**Headquarters: 20 Industrial Way, Rochester, NH, USA 03867 • 603.335.6300 • Fax 603.335.3355**  
 9 Brigden Gate, Halton Hills, Ontario, Canada L7G 0A3 • 905.203.0600 • Fax 905.636.0666  
[www.Laars.com](http://www.Laars.com)

# Tank, Horizontal Bare

STHGB48096    STH2B48096  
 STHDB48096    STH3B48096  
 STHEB48096



## Design

- STHGB Carbon Steel, Glass Lined  
Primed Painted Exterior  
Five-Year Tank Limited Warranty
- STHDB Carbon Steel, Double-Glass Lined  
Primed Painted Exterior  
Ten-Year Tank Limited Warranty
- STHEB Carbon Steel, Epoxy Lining  
Primed Painted Exterior  
One-Year Tank Limited Warranty
- STH2B Duplex Stainless Steel  
Twenty-Five-Year\* Tank Limited Warranty  
\*See warranty sheet for details
- STH3B 316L Stainless Steel  
Ten-Year Tank Limited Warranty

## Submittal Data

Date:

Project #:

Engineer:

Project Name:

Prepared By:

Location:

Bid Date:

Contractor:

Code	ASME Sec IV HLW
Design Pressure	125 psi
Parts Warranty	One Year, Limited
Supports	Saddles
Capacity	675 Gallons
Nominal Capacity	752 Gallons
Weight	1350 Lbs.

## Dimensions

Callout	Value	Description
A	96"	Overall Length
B	57"	Overall Height
C	48"	Diameter
D	30"	Circulation
E	36"	Supports
F	42.1"	Support Width

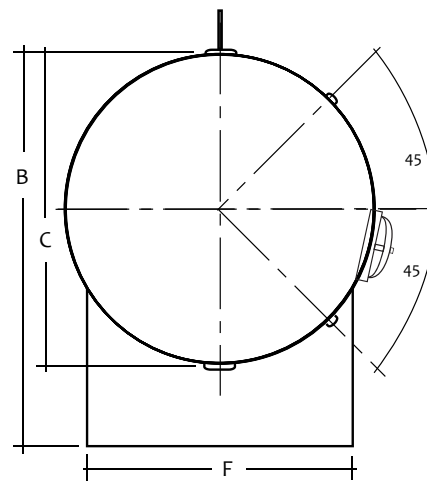
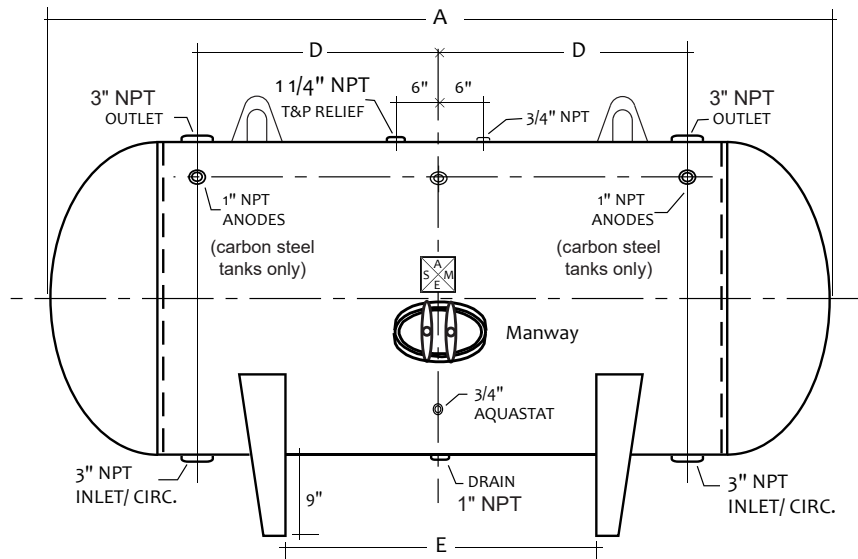

## Options

- 150 PSI Vessel
- Hand Hole
- Optional Fittings / Additional Notes:



Customer Service and Product Support: 800.900.9276 • Fax 800.559.1583  
 Headquarters: 20 Industrial Way, Rochester, NH, USA 03867 • 603.335.6300 • Fax 603.335.3355  
 9 Brigden Gate, Halton Hills, Ontario, Canada L7G 0A3 • 905.203.0600 • Fax 905.636.0666

[www.Laars.com](http://www.Laars.com)

Litho in U.S.A. © Laars Heating Systems 20-09 Document 4223F

# Tank, Horizontal Bare

STHGB48108    STH2B48108  
 STHDB48108    STH3B48108  
 STHEB48108



## Design

- STHGB Carbon Steel, Glass Lined  
Primed Painted Exterior  
Five-Year Tank Limited Warranty
- STHDB Carbon Steel, Double-Glass Lined  
Primed Painted Exterior  
Ten-Year Tank Limited Warranty
- STHEB Carbon Steel, Epoxy Lining  
Primed Painted Exterior  
One-Year Tank Limited Warranty
- STH2B Duplex Stainless Steel  
Twenty-Five-Year\* Tank Limited Warranty  
\*See warranty sheet for details
- STH3B 316L Stainless Steel  
Ten-Year Tank Limited Warranty

## Submittal Data

Date:

Project #:

Engineer:

Project Name:

Prepared By:

Location:

Bid Date:

Contractor:

Code	ASME Sec IV HLW
Design Pressure	125 psi
Parts Warranty	One Year, Limited
Supports	Saddles
Capacity	765 Gallons
Nominal Capacity	846 Gallons
Weight	1485 Lbs.

## Dimensions

Callout	Value	Description
A	108"	Overall Length
B	57"	Overall Height
C	48"	Diameter
D	36"	Circulation
E	48"	Supports
F	42.1"	Support Width

## Options

- 150 PSI Vessel
- Hand Hole
- Optional Fittings / Additional Notes:

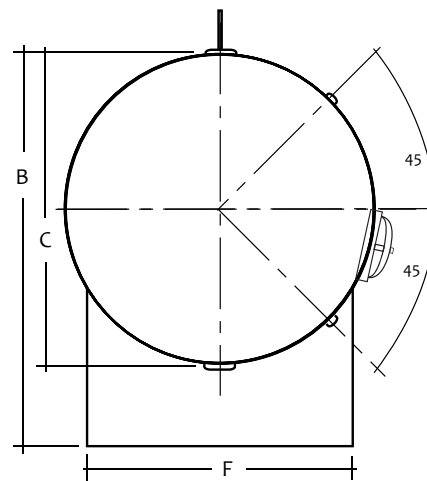
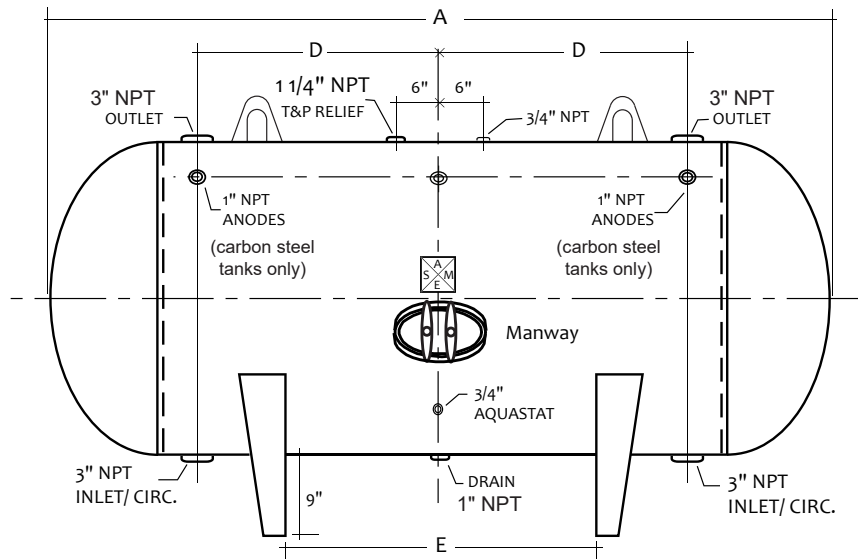

Customer Service and Product Support: 800.900.9276 • Fax 800.559.1583  
 Headquarters: 20 Industrial Way, Rochester, NH, USA 03867 • 603.335.6300 • Fax 603.335.3355  
 9 Brigden Gate, Halton Hills, Ontario, Canada L7G 0A3 • 905.203.0600 • Fax 905.636.0666  
[www.Laars.com](http://www.Laars.com)      Litho in U.S.A. © Laars Heating Systems 20-09 Document 4223F

# Tank, Horizontal Bare

STHGB48120    STH2B48120  
 STHDB48120    STH3B48120  
 STHEB48120



## Design

- STHGB Carbon Steel, Glass Lined  
Primed Painted Exterior  
Five-Year Tank Limited Warranty
- STHDB Carbon Steel, Double-Glass Lined  
Primed Painted Exterior  
Ten-Year Tank Limited Warranty
- STHEB Carbon Steel, Epoxy Lining  
Primed Painted Exterior  
One-Year Tank Limited Warranty
- STH2B Duplex Stainless Steel  
Twenty-Five-Year\* Tank Limited Warranty  
\*See warranty sheet for details
- STH3B 316L Stainless Steel  
Ten-Year Tank Limited Warranty

Date:

Project #:

Engineer:

Prepared By:

Bid Date:

## Submittal Data

Project Name:

Location:

Contractor:

Code	ASME Sec IV HLW
Design Pressure	125 psi
Parts Warranty	One Year, Limited
Supports	Saddles
Capacity	860 Gallons
Nominal Capacity	940 Gallons
Weight	1619 Lbs.

## Dimensions

Callout	Value	Description
A	120"	Overall Length
B	57"	Overall Height
C	48"	Diameter
D	42"	Circulation
E	60"	Supports
F	42.1"	Support Width

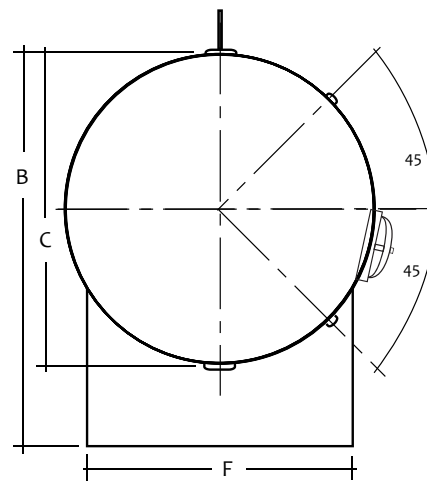
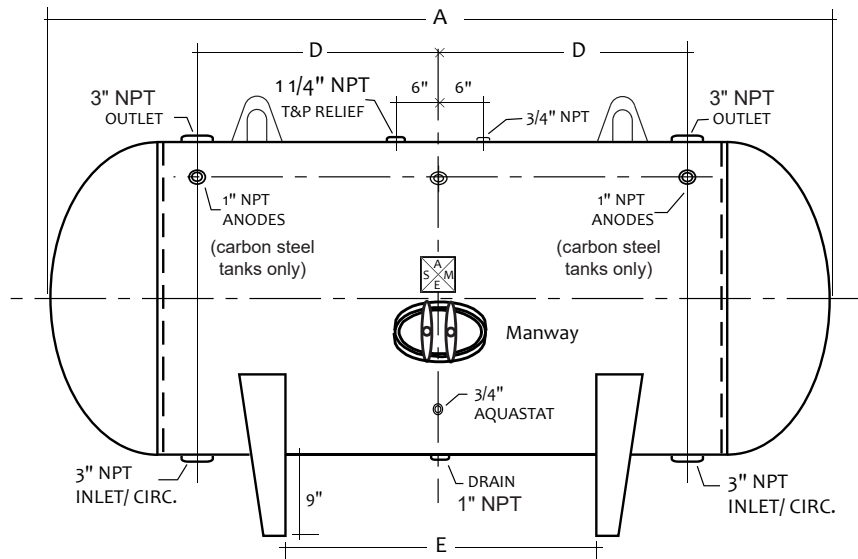

## Options

- 150 PSI Vessel
- Hand Hole
- Optional Fittings / Additional Notes:



Customer Service and Product Support: 800.900.9276 • Fax 800.559.1583  
 Headquarters: 20 Industrial Way, Rochester, NH, USA 03867 • 603.335.6300 • Fax 603.335.3355  
 9 Brigden Gate, Halton Hills, Ontario, Canada L7G 0A3 • 905.203.0600 • Fax 905.636.0666

[www.Laars.com](http://www.Laars.com)

Litho in U.S.A. © Laars Heating Systems 20-09 Document 4223F



# Tank, Horizontal Bare

STHGB48141    STH2B48141  
 STHDB48141    STH3B48141  
 STHEB48141



## Design

- STHGB Carbon Steel, Glass Lined  
Primed Painted Exterior  
Five-Year Tank Limited Warranty
- STHDB Carbon Steel, Double-Glass Lined  
Primed Painted Exterior  
Ten-Year Tank Limited Warranty
- STHEB Carbon Steel, Epoxy Lining  
Primed Painted Exterior  
One-Year Tank Limited Warranty
- STH2B Duplex Stainless Steel  
Twenty-Five-Year\* Tank Limited Warranty  
\*See warranty sheet for details
- STH3B 316L Stainless Steel  
Ten-Year Tank Limited Warranty

Date:

Project #:

Engineer:

Prepared By:

Bid Date:

## Submittal Data

Project Name:

Location:

Contractor:

Code	ASME Sec IV HLW
Design Pressure	125 psi
Parts Warranty	One Year, Limited
Supports	Saddles
Capacity	1040 Gallons
Nominal Capacity	1128 Gallons
Weight	1857 Lbs.

## Dimensions

Callout	Value	Description
A	141"	Overall Length
B	57"	Overall Height
C	48"	Diameter
D	52.5"	Circulation
E	81"	Supports
F	42.1"	Support Width

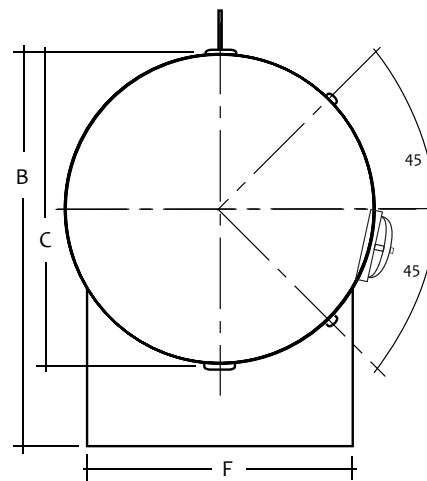
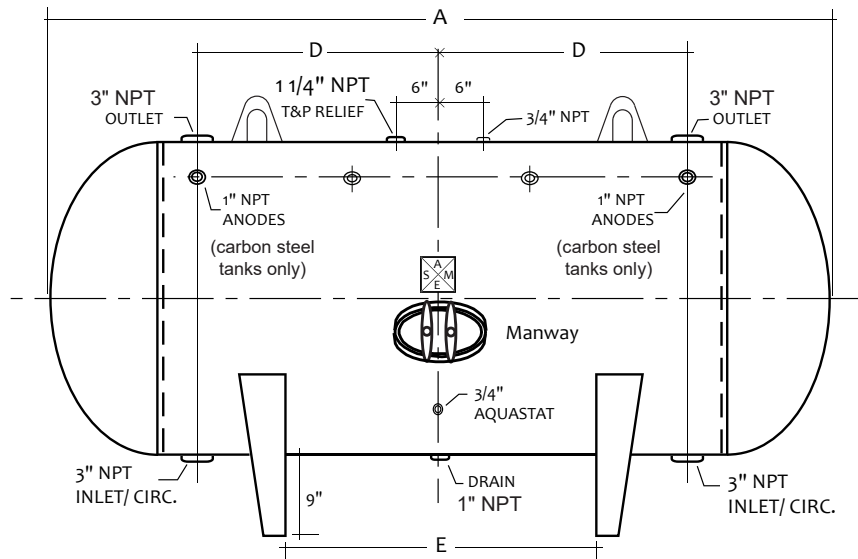

## Options

- 150 PSI Vessel
- Hand Hole
- Optional Fittings / Additional Notes:



Customer Service and Product Support: 800.900.9276 • Fax 800.559.1583  
 Headquarters: 20 Industrial Way, Rochester, NH, USA 03867 • 603.335.6300 • Fax 603.335.3355  
 9 Brigden Gate, Halton Hills, Ontario, Canada L7G 0A3 • 905.203.0600 • Fax 905.636.0666  
[www.Laars.com](http://www.Laars.com)      Litho in U.S.A. © Laars Heating Systems 20-09 Document 4223F

# Tank, Horizontal Bare

STHGB48168    STH2B48168  
 STHDB48168    STH3B48168  
 STHEB48168



## Design

- STHGB Carbon Steel, Glass Lined  
Primed Painted Exterior  
Five-Year Tank Limited Warranty
- STHDB Carbon Steel, Double-Glass Lined  
Primed Painted Exterior  
Ten-Year Tank Limited Warranty
- STHEB Carbon Steel, Epoxy Lining  
Primed Painted Exterior  
One-Year Tank Limited Warranty
- STH2B Duplex Stainless Steel  
Twenty-Five-Year\* Tank Limited Warranty  
\*See warranty sheet for details
- STH3B 316L Stainless Steel  
Ten-Year Tank Limited Warranty

## Submittal Data

Date:

Project #:

Engineer:

Project Name:

Prepared By:

Location:

Bid Date:

Contractor:

Code	ASME Sec IV HLW
Design Pressure	125 psi
Parts Warranty	One Year, Limited
Supports	Saddles
Capacity	1225 Gallons
Nominal Capacity	1306 Gallons
Weight	2160 Lbs.

## Dimensions

Callout	Value	Description
A	168"	Overall Length
B	57"	Overall Height
C	48"	Diameter
D	52.5"	Circulation
E	108"	Supports
F	42.1"	Support Width

## Options

- 150 PSI Vessel
- Hand Hole
- Optional Fittings / Additional Notes:

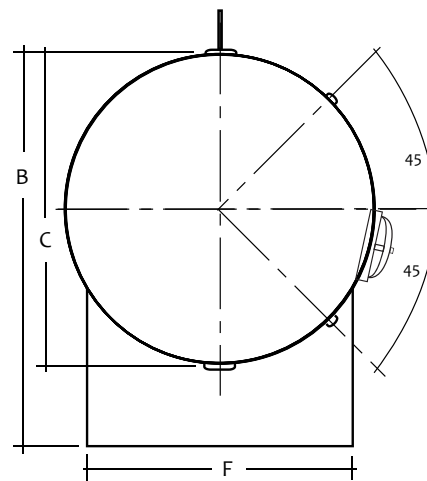
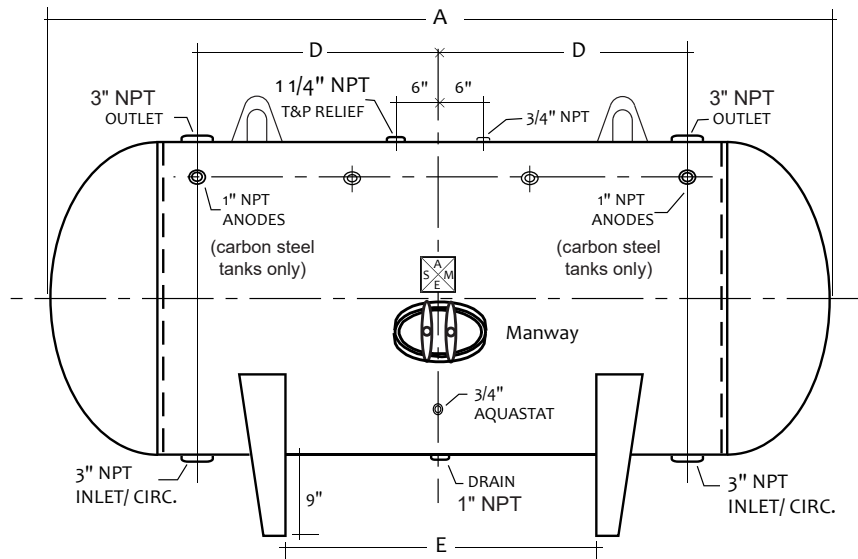

Customer Service and Product Support: 800.900.9276 • Fax 800.559.1583  
 Headquarters: 20 Industrial Way, Rochester, NH, USA 03867 • 603.335.6300 • Fax 603.335.3355  
 9 Brigden Gate, Halton Hills, Ontario, Canada L7G 0A3 • 905.203.0600 • Fax 905.636.0666  
[www.Laars.com](http://www.Laars.com)      Litho in U.S.A. © Laars Heating Systems 20-09 Document 4223F

# Tank, Horizontal Bare

STHGB54099    STH2B54099  
 STHDB54099    STH3B54099  
 STHEB54099



## Design

- STHGB Carbon Steel, Glass Lined  
Primed Painted Exterior  
Five-Year Tank Limited Warranty
- STHDB Carbon Steel, Double-Glass Lined  
Primed Painted Exterior  
Ten-Year Tank Limited Warranty
- STHEB Carbon Steel, Epoxy Lining  
Primed Painted Exterior  
One-Year Tank Limited Warranty
- STH2B Duplex Stainless Steel  
Twenty-Five-Year\* Tank Limited Warranty  
\*See warranty sheet for details
- STH3B 316L Stainless Steel  
Ten-Year Tank Limited Warranty

## Submittal Data

Date:

Project #:

Engineer:

Project Name:

Prepared By:

Location:

Bid Date:

Contractor:

Code	ASME Sec IV HLW
Design Pressure	125 psi
Parts Warranty	One Year, Limited
Supports	Saddles
Capacity	875 Gallons
Nominal Capacity	981 Gallons
Weight	1696 Lbs.

## Dimensions

Callout	Value	Description
A	99"	Overall Length
B	63"	Overall Height
C	54"	Diameter
D	37.5"	Circulation
E	48"	Supports
F	47.3"	Support Width

## Options

- 150 PSI Vessel
- Hand Hole
- Optional Fittings / Additional Notes:

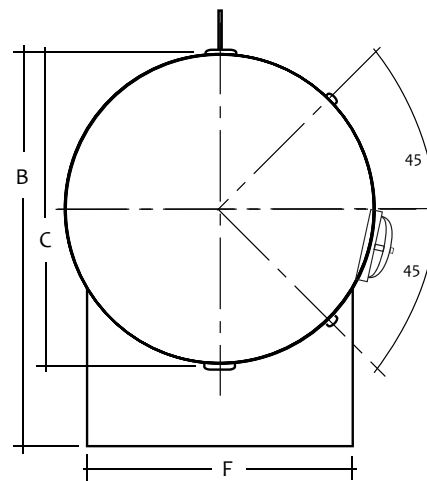
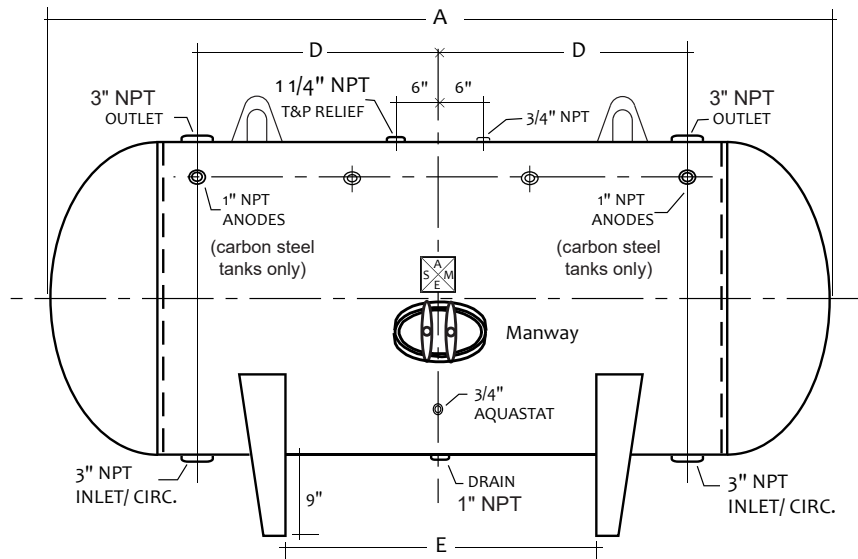

Customer Service and Product Support: 800.900.9276 • Fax 800.559.1583  
 Headquarters: 20 Industrial Way, Rochester, NH, USA 03867 • 603.335.6300 • Fax 603.335.3355  
 9 Brigden Gate, Halton Hills, Ontario, Canada L7G 0A3 • 905.203.0600 • Fax 905.636.0666  
[www.Laars.com](http://www.Laars.com)    Litho in U.S.A. © Laars Heating Systems 20-09 Document 4223F

# Tank, Horizontal Bare

STHGB54123

STH2B54123

STHDB54123

STH3B54123

STHEB54123



## Design

- STHGB Carbon Steel, Glass Lined  
Primed Painted Exterior  
Five-Year Tank Limited Warranty
- STHDB Carbon Steel, Double-Glass Lined  
Primed Painted Exterior  
Ten-Year Tank Limited Warranty
- STHEB Carbon Steel, Epoxy Lining  
Primed Painted Exterior  
One-Year Tank Limited Warranty
- STH2B Duplex Stainless Steel  
Twenty-Five-Year\* Tank Limited Warranty  
\*See warranty sheet for details
- STH3B 316L Stainless Steel  
Ten-Year Tank Limited Warranty

## Submittal Data

Date:

Project #:

Engineer:

Project Name:

Prepared By:

Location:

Bid Date:

Contractor:

Code	ASME Sec IV HLW
Design Pressure	125 psi
Parts Warranty	One Year, Limited
Supports	Saddles
Capacity	1110 Gallons
Nominal Capacity	1219 Gallons
Weight	2124 Lbs.

## Dimensions

Callout	Value	Description
A	123"	Overall Length
B	63"	Overall Height
C	54"	Diameter
D	49.5"	Circulation
E	57.5"	Supports
F	47.3"	Support Width

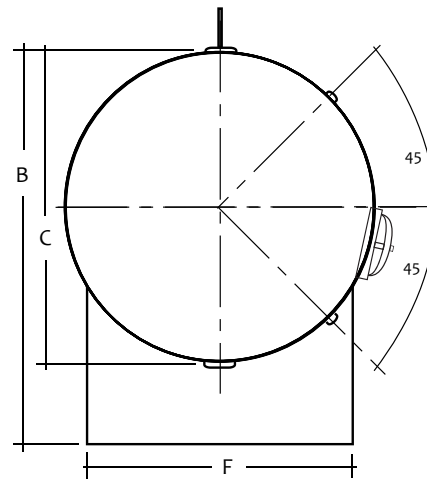
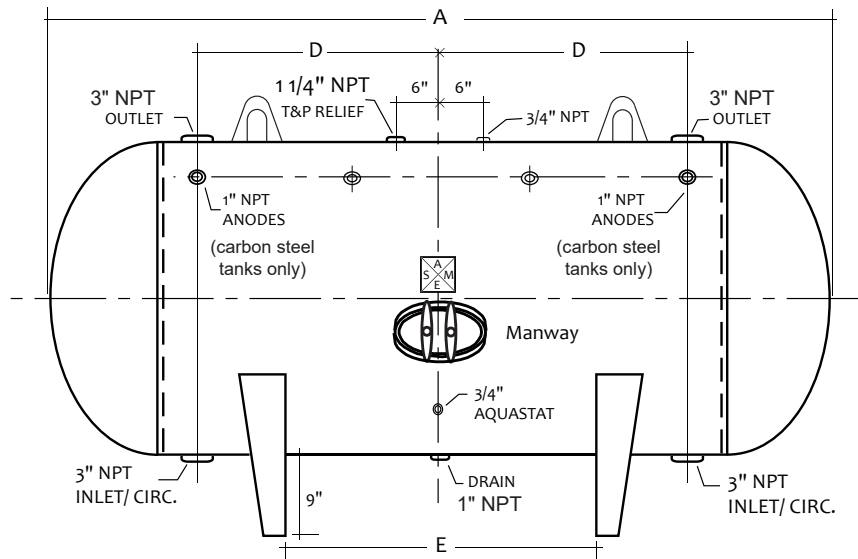

## Options

- 150 PSI Vessel
- Hand Hole
- Optional Fittings / Additional Notes:



Customer Service and Product Support: 800.900.9276 • Fax 800.559.1583  
 Headquarters: 20 Industrial Way, Rochester, NH, USA 03867 • 603.335.6300 • Fax 603.335.3355  
 9 Brigden Gate, Halton Hills, Ontario, Canada L7G 0A3 • 905.203.0600 • Fax 905.636.0666

[www.Laars.com](http://www.Laars.com)

Litho in U.S.A. © Laars Heating Systems 20-09 Document 4223F

# Tank, Horizontal Bare

STHGB54134    STH2B54134  
 STHDB54134    STH3B54134  
 STHEB54134



## Design

- STHGB Carbon Steel, Glass Lined  
Primed Painted Exterior  
Five-Year Tank Limited Warranty
- STHDB Carbon Steel, Double-Glass Lined  
Primed Painted Exterior  
Ten-Year Tank Limited Warranty
- STHEB Carbon Steel, Epoxy Lining  
Primed Painted Exterior  
One-Year Tank Limited Warranty
- STH2B Duplex Stainless Steel  
Twenty-Five-Year\* Tank Limited Warranty  
\*See warranty sheet for details
- STH3B 316L Stainless Steel  
Ten-Year Tank Limited Warranty

## Submittal Data

Date:

Project #:

Engineer:

Project Name:

Prepared By:

Location:

Bid Date:

Contractor:

Code	ASME Sec IV HLW
Design Pressure	125 psi
Parts Warranty	One Year, Limited
Supports	Saddles
Capacity	1217 Gallons
Nominal Capacity	1327 Gallons
Weight	2252 Lbs.

## Dimensions

Callout	Value	Description
A	134"	Overall Length
B	63"	Overall Height
C	54"	Diameter
D	61.5"	Circulation
E	68.5"	Supports
F	47.3"	Support Width

## Options

- 150 PSI Vessel
- Hand Hole
- Optional Fittings / Additional Notes:

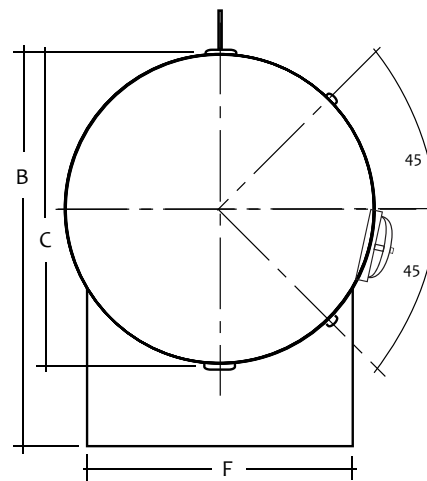
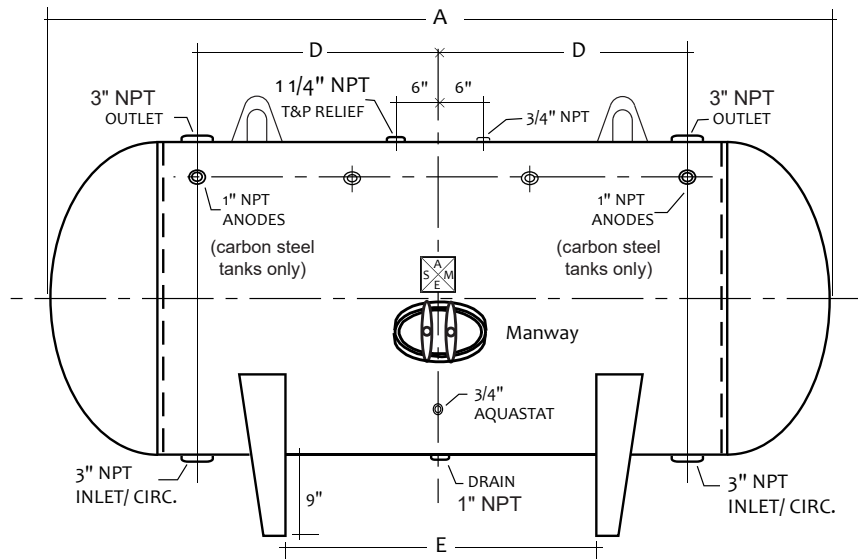

Customer Service and Product Support: 800.900.9276 • Fax 800.559.1583  
 Headquarters: 20 Industrial Way, Rochester, NH, USA 03867 • 603.335.6300 • Fax 603.335.3355  
 9 Brigden Gate, Halton Hills, Ontario, Canada L7G 0A3 • 905.203.0600 • Fax 905.636.0666  
[www.Laars.com](http://www.Laars.com)      Litho in U.S.A. © Laars Heating Systems 20-09 Document 4223F

# Tank, Horizontal Bare

STHGB54147    STH2B54147  
 STHDB54147    STH3B54147  
 STHEB54147



## Design

- STHGB Carbon Steel, Glass Lined  
Primed Painted Exterior  
Five-Year Tank Limited Warranty
- STHDB Carbon Steel, Double-Glass Lined  
Primed Painted Exterior  
Ten-Year Tank Limited Warranty
- STHEB Carbon Steel, Epoxy Lining  
Primed Painted Exterior  
One-Year Tank Limited Warranty
- STH2B Duplex Stainless Steel  
Twenty-Five-Year\* Tank Limited Warranty  
\*See warranty sheet for details
- STH3B 316L Stainless Steel  
Ten-Year Tank Limited Warranty

## Submittal Data

Date:

Project #:

Engineer:

Project Name:

Prepared By:

Location:

Bid Date:

Contractor:

Code	ASME Sec IV HLW
Design Pressure	125 psi
Parts Warranty	One Year, Limited
Supports	Saddles
Capacity	1340 Gallons
Nominal Capacity	1457 Gallons
Weight	2306 Lbs.

## Dimensions

Callout	Value	Description
A	147"	Overall Length
B	63"	Overall Height
C	54"	Diameter
D	61.5"	Circulation
E	81.5"	Supports
F	47.3"	Support Width

## Options

- 150 PSI Vessel
- Hand Hole
- Optional Fittings / Additional Notes:

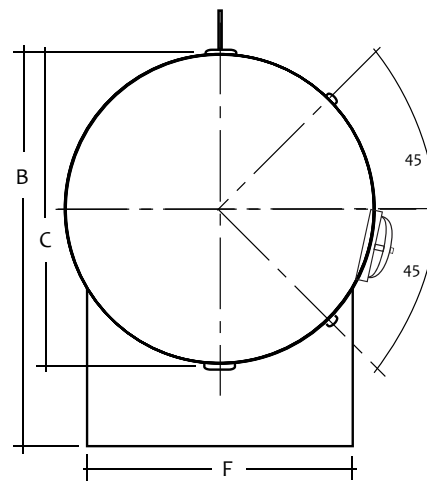
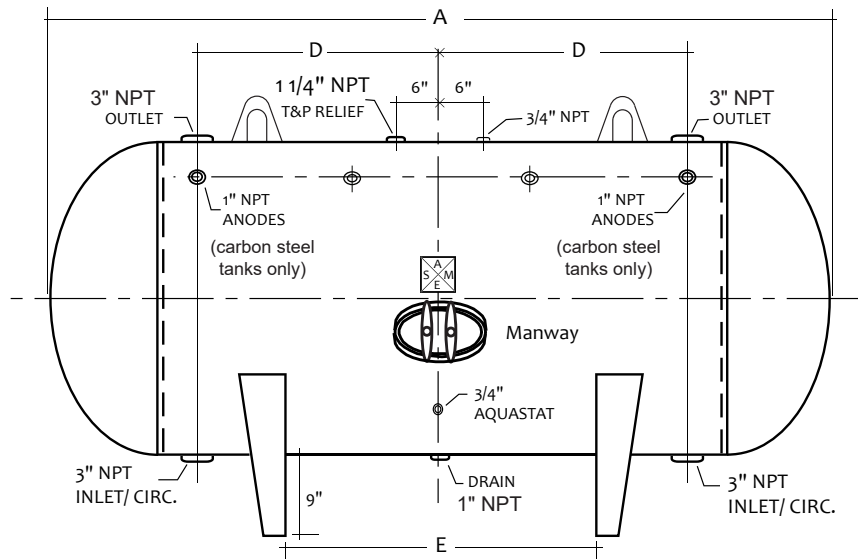

Customer Service and Product Support: 800.900.9276 • Fax 800.559.1583  
 Headquarters: 20 Industrial Way, Rochester, NH, USA 03867 • 603.335.6300 • Fax 603.335.3355  
 9 Brigden Gate, Halton Hills, Ontario, Canada L7G 0A3 • 905.203.0600 • Fax 905.636.0666

[www.Laars.com](http://www.Laars.com)

Litho in U.S.A. © Laars Heating Systems 20-09 Document 4223F

# Tank, Horizontal Bare

STHGB54165    STH2B54165  
 STHDB54165    STH3B54165  
 STHEB54165



## Design

- STHGB Carbon Steel, Glass Lined  
Primed Painted Exterior  
Five-Year Tank Limited Warranty
- STHDB Carbon Steel, Double-Glass Lined  
Primed Painted Exterior  
Ten-Year Tank Limited Warranty
- STHEB Carbon Steel, Epoxy Lining  
Primed Painted Exterior  
One-Year Tank Limited Warranty
- STH2B Duplex Stainless Steel  
Twenty-Five-Year\* Tank Limited Warranty  
\*See warranty sheet for details
- STH3B 316L Stainless Steel  
Ten-Year Tank Limited Warranty

## Submittal Data

Date:

Project #:

Engineer:

Project Name:

Prepared By:

Location:

Bid Date:

Contractor:

Code	ASME Sec IV HLW
Design Pressure	125 psi
Parts Warranty	One Year, Limited
Supports	Saddles
Capacity	1500 Gallons
Nominal Capacity	1635 Gallons
Weight	2734 Lbs.

## Dimensions

Callout	Value	Description
A	165"	Overall Length
B	63"	Overall Height
C	54"	Diameter
D	61.5"	Circulation
E	99.5"	Supports
F	47.3"	Support Width

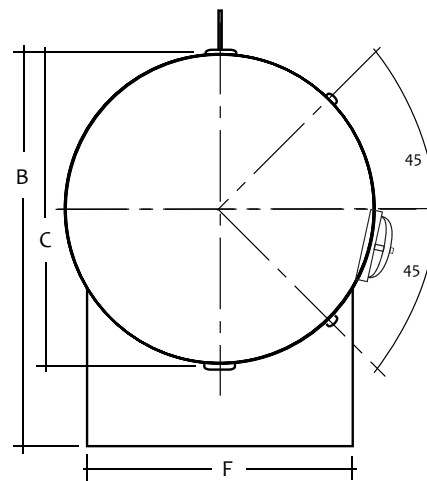
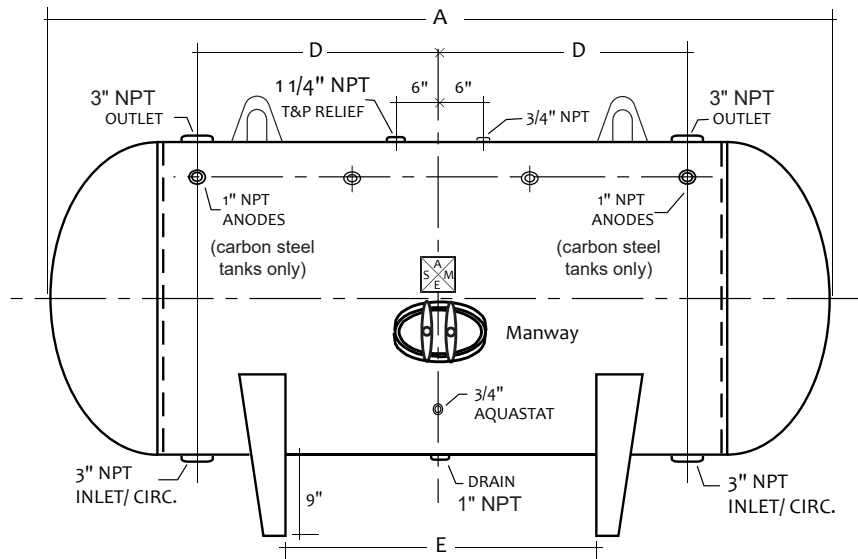

## Options

- 150 PSI Vessel
- Hand Hole
- Optional Fittings / Additional Notes:



Customer Service and Product Support: 800.900.9276 • Fax 800.559.1583  
 Headquarters: 20 Industrial Way, Rochester, NH, USA 03867 • 603.335.6300 • Fax 603.335.3355  
 9 Brigden Gate, Halton Hills, Ontario, Canada L7G 0A3 • 905.203.0600 • Fax 905.636.0666

[www.Laars.com](http://www.Laars.com)

Litho in U.S.A. © Laars Heating Systems 20-09 Document 4223F

# Tank, Horizontal Bare

STHGB54183    STH2B54183  
 STHDB54183    STH3B54183  
 STHEB54183



## Design

- STHGB Carbon Steel, Glass Lined  
Primed Painted Exterior  
Five-Year Tank Limited Warranty
- STHDB Carbon Steel, Double-Glass Lined  
Primed Painted Exterior  
Ten-Year Tank Limited Warranty
- STHEB Carbon Steel, Epoxy Lining  
Primed Painted Exterior  
One-Year Tank Limited Warranty
- STH2B Duplex Stainless Steel  
Twenty-Five-Year\* Tank Limited Warranty  
\*See warranty sheet for details
- STH3B 316L Stainless Steel  
Ten-Year Tank Limited Warranty

## Submittal Data

Date:

Project #:

Engineer:

Project Name:

Prepared By:

Location:

Bid Date:

Contractor:

Code	ASME Sec IV HLW
Design Pressure	125 psi
Parts Warranty	One Year, Limited
Supports	Saddles
Capacity	1690 Gallons
Nominal Capacity	1814 Gallons
Weight	2972 Lbs.

## Dimensions

Callout	Value	Description
A	183"	Overall Length
B	63"	Overall Height
C	54"	Diameter
D	79.5"	Circulation
E	117.5"	Supports
F	47.3"	Support Width

## Options

- 150 PSI Vessel
- Hand Hole
- Optional Fittings / Additional Notes:

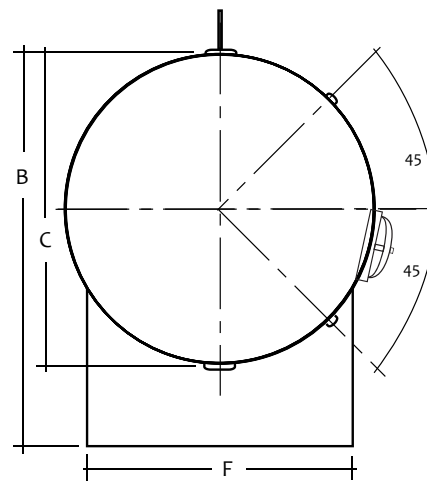
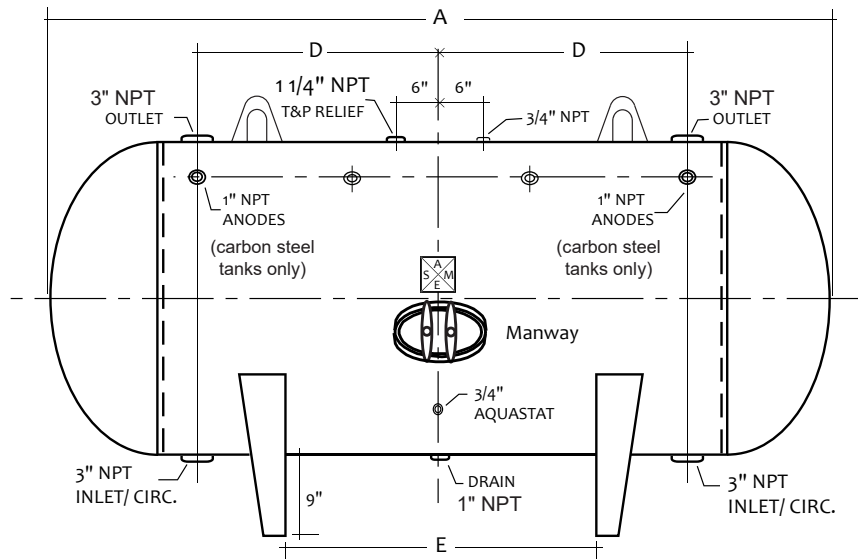

Customer Service and Product Support: 800.900.9276 • Fax 800.559.1583  
 Headquarters: 20 Industrial Way, Rochester, NH, USA 03867 • 603.335.6300 • Fax 603.335.3355  
 9 Brigden Gate, Halton Hills, Ontario, Canada L7G 0A3 • 905.203.0600 • Fax 905.636.0666  
[www.Laars.com](http://www.Laars.com)      Litho in U.S.A. © Laars Heating Systems 20-09 Document 4223F



# Tank, Horizontal Bare

STHGB60096    STH2B60096  
 STHDB60096    STH3B60096  
 STHEB60096



## Design

- STHGB Carbon Steel, Glass Lined  
Primed Painted Exterior  
Five-Year Tank Limited Warranty
- STHDB Carbon Steel, Double-Glass Lined  
Primed Painted Exterior  
Ten-Year Tank Limited Warranty
- STHEB Carbon Steel, Epoxy Lining  
Primed Painted Exterior  
One-Year Tank Limited Warranty
- STH2B Duplex Stainless Steel  
Twenty-Five-Year\* Tank Limited Warranty  
\*See warranty sheet for details
- STH3B 316L Stainless Steel  
Ten-Year Tank Limited Warranty

## Submittal Data

Date:

Project #:

Engineer:

Project Name:

Prepared By:

Location:

Bid Date:

Contractor:

Code	ASME Sec IV HLW
Design Pressure	125 psi
Parts Warranty	One Year, Limited
Supports	Saddles
Capacity	1000 Gallons
Nominal Capacity	1174 Gallons
Weight	2548 Lbs.

## Dimensions

Callout	Value	Description
A	96"	Overall Length
B	69"	Overall Height
C	60"	Diameter
D	28.5"	Circulation
E	34"	Supports
F	52.5"	Support Width

## Options

- 150 PSI Vessel
- Hand Hole
- Optional Fittings / Additional Notes:

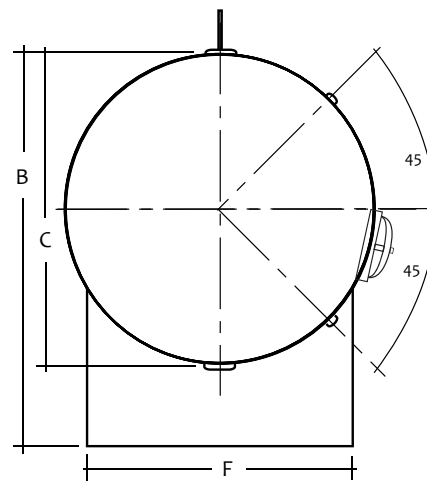
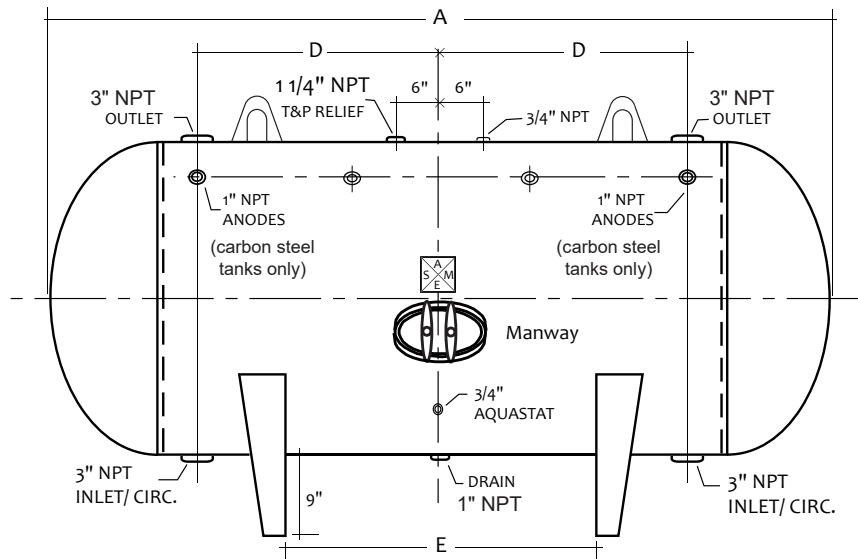

Customer Service and Product Support: 800.900.9276 • Fax 800.559.1583  
 Headquarters: 20 Industrial Way, Rochester, NH, USA 03867 • 603.335.6300 • Fax 603.335.3355  
 9 Brigden Gate, Halton Hills, Ontario, Canada L7G 0A3 • 905.203.0600 • Fax 905.636.0666  
[www.Laars.com](http://www.Laars.com)    Litho in U.S.A. © Laars Heating Systems 20-09 Document 4223F

# Tank, Horizontal Bare

STHGB60114    STH2B60114  
 STHDB60114    STH3B60114  
 STHEB60114



## Design

- STHGB Carbon Steel, Glass Lined  
Primed Painted Exterior  
Five-Year Tank Limited Warranty
- STHDB Carbon Steel, Double-Glass Lined  
Primed Painted Exterior  
Ten-Year Tank Limited Warranty
- STHEB Carbon Steel, Epoxy Lining  
Primed Painted Exterior  
One-Year Tank Limited Warranty
- STH2B Duplex Stainless Steel  
Twenty-Five-Year\* Tank Limited Warranty  
\*See warranty sheet for details
- STH3B 316L Stainless Steel  
Ten-Year Tank Limited Warranty

## Submittal Data

Date:

Project #:

Engineer:

Project Name:

Prepared By:

Location:

Bid Date:

Contractor:

Code	ASME Sec IV HLW
Design Pressure	125 psi
Parts Warranty	One Year, Limited
Supports	Saddles
Capacity	1245 Gallons
Nominal Capacity	1395 Gallons
Weight	2648 Lbs.

## Dimensions

Callout	Value	Description
A	114"	Overall Length
B	69"	Overall Height
C	60"	Diameter
D	24"	Circulation
E	45.5"	Supports
F	52.5"	Support Width

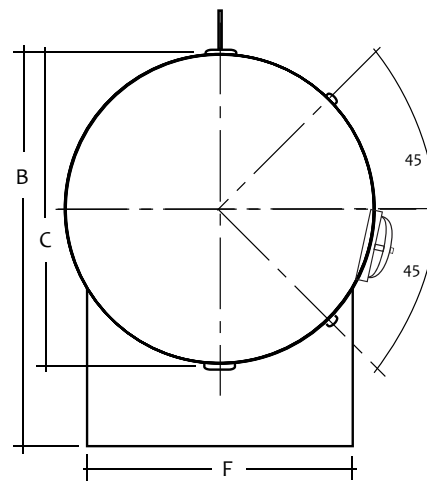
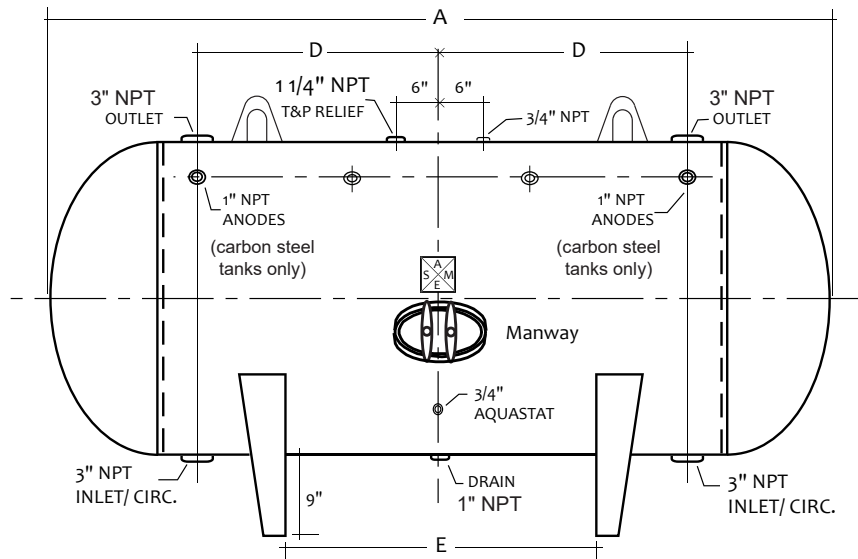

## Options

- 150 PSI Vessel
- Hand Hole
- Optional Fittings / Additional Notes:



Customer Service and Product Support: 800.900.9276 • Fax 800.559.1583  
 Headquarters: 20 Industrial Way, Rochester, NH, USA 03867 • 603.335.6300 • Fax 603.335.3355  
 9 Brigden Gate, Halton Hills, Ontario, Canada L7G 0A3 • 905.203.0600 • Fax 905.636.0666

www.Laars.com

Litho in U.S.A. © Laars Heating Systems 20-09 Document 4223F

# Tank, Horizontal Bare

STHGB60138    STH2B60138  
 STHDB60138    STH3B60138  
 STHEB60138



## Design

- STHGB Carbon Steel, Glass Lined  
Primed Painted Exterior  
Five-Year Tank Limited Warranty
- STHDB Carbon Steel, Double-Glass Lined  
Primed Painted Exterior  
Ten-Year Tank Limited Warranty
- STHEB Carbon Steel, Epoxy Lining  
Primed Painted Exterior  
One-Year Tank Limited Warranty
- STH2B Duplex Stainless Steel  
Twenty-Five-Year\* Tank Limited Warranty  
\*See warranty sheet for details
- STH3B 316L Stainless Steel  
Ten-Year Tank Limited Warranty

## Submittal Data

Date:

Project #:

Engineer:

Project Name:

Prepared By:

Location:

Bid Date:

Contractor:

Code	ASME Sec IV HLW
Design Pressure	125 psi
Parts Warranty	One Year, Limited
Supports	Saddles
Capacity	1530 Gallons
Nominal Capacity	1689 Gallons
Weight	2829 Lbs.

## Dimensions

Callout	Value	Description
A	138"	Overall Length
B	69"	Overall Height
C	60"	Diameter
D	48"	Circulation
E	69.5"	Supports
F	52.5"	Support Width

## Options

- 150 PSI Vessel
- Hand Hole
- Optional Fittings / Additional Notes:

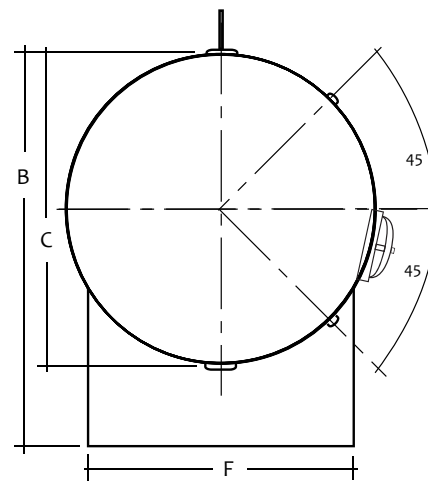
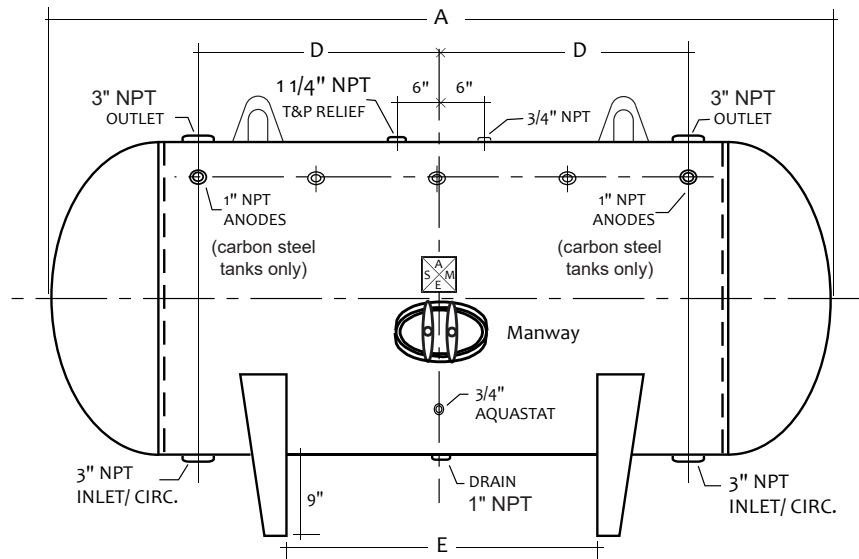

Customer Service and Product Support: 800.900.9276 • Fax 800.559.1583  
 Headquarters: 20 Industrial Way, Rochester, NH, USA 03867 • 603.335.6300 • Fax 603.335.3355  
 9 Brigden Gate, Halton Hills, Ontario, Canada L7G 0A3 • 905.203.0600 • Fax 905.636.0666  
[www.Laars.com](http://www.Laars.com)      Litho in U.S.A. © Laars Heating Systems 20-09 Document 4223F

# Tank, Horizontal Bare

STHGB60168    STH2B60168  
 STHDB60168    STH3B60168  
 STHEB60168



## Design

- STHGB Carbon Steel, Glass Lined  
Primed Painted Exterior  
Five-Year Tank Limited Warranty
- STHDB Carbon Steel, Double-Glass Lined  
Primed Painted Exterior  
Ten-Year Tank Limited Warranty
- STHEB Carbon Steel, Epoxy Lining  
Primed Painted Exterior  
One-Year Tank Limited Warranty
- STH2B Duplex Stainless Steel  
Twenty-Five-Year\* Tank Limited Warranty  
\*See warranty sheet for details
- STH3B 316L Stainless Steel  
Ten-Year Tank Limited Warranty

## Submittal Data

Date:

Project #:

Engineer:

Project Name:

Prepared By:

Location:

Bid Date:

Contractor:

Code	ASME Sec IV HLW
Design Pressure	125 psi
Parts Warranty	One Year, Limited
Supports	Saddles
Capacity	1820 Gallons
Nominal Capacity	1983 Gallons
Weight	3560 Lbs.

## Dimensions

Callout	Value	Description
A	168"	Overall Length
B	69"	Overall Height
C	60"	Diameter
D	60"	Circulation
E	96"	Supports
F	52.5"	Support Width

## Options

- 150 PSI Vessel
- Hand Hole
- Optional Fittings / Additional Notes:

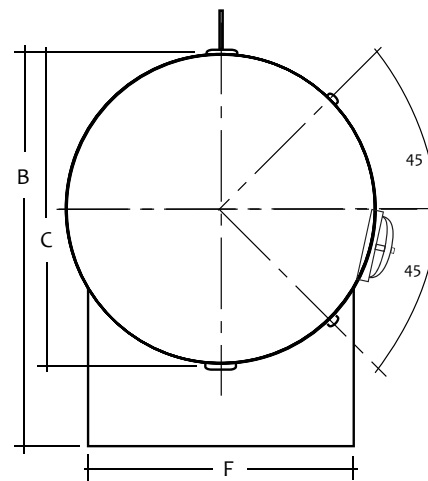
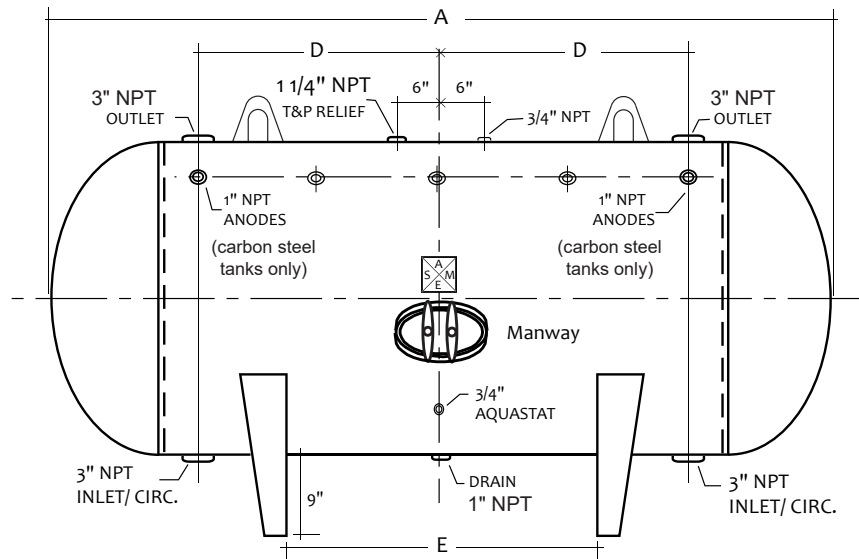

Customer Service and Product Support: 800.900.9276 • Fax 800.559.1583  
 Headquarters: 20 Industrial Way, Rochester, NH, USA 03867 • 603.335.6300 • Fax 603.335.3355  
 9 Brigden Gate, Halton Hills, Ontario, Canada L7G 0A3 • 905.203.0600 • Fax 905.636.0666  
[www.Laars.com](http://www.Laars.com)    Litho in U.S.A. © Laars Heating Systems 20-09 Document 4223F

# Tank, Horizontal Bare

STHGB60177    STH2B60177  
 STHDB60177    STH3B60177  
 STHEB60177



## Design

- STHGB Carbon Steel, Glass Lined  
Primed Painted Exterior  
Five-Year Tank Limited Warranty
- STHDB Carbon Steel, Double-Glass Lined  
Primed Painted Exterior  
Ten-Year Tank Limited Warranty
- STHEB Carbon Steel, Epoxy Lining  
Primed Painted Exterior  
One-Year Tank Limited Warranty
- STH2B Duplex Stainless Steel  
Twenty-Five-Year\* Tank Limited Warranty  
\*See warranty sheet for details
- STH3B 316L Stainless Steel  
Ten-Year Tank Limited Warranty

## Submittal Data

Date:

Project #:

Engineer:

Project Name:

Prepared By:

Location:

Bid Date:

Contractor:

Code	ASME Sec IV HLW
Design Pressure	125 psi
Parts Warranty	One Year, Limited
Supports	Saddles
Capacity	2000 Gallons
Nominal Capacity	2165 Gallons
Weight	3491 Lbs.

## Dimensions

Callout	Value	Description
A	177"	Overall Length
B	69"	Overall Height
C	60"	Diameter
D	67.5"	Circulation
E	110"	Supports
F	52.5"	Support Width

## Options

- 150 PSI Vessel
- Hand Hole
- Optional Fittings / Additional Notes:

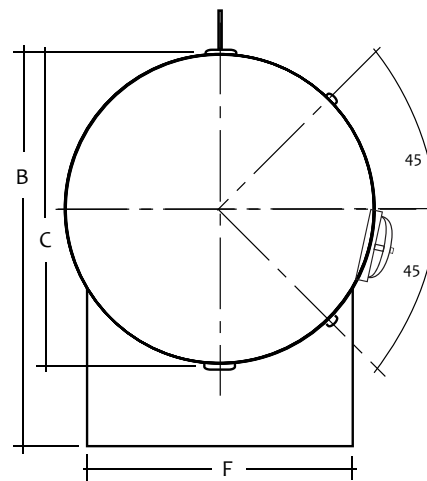
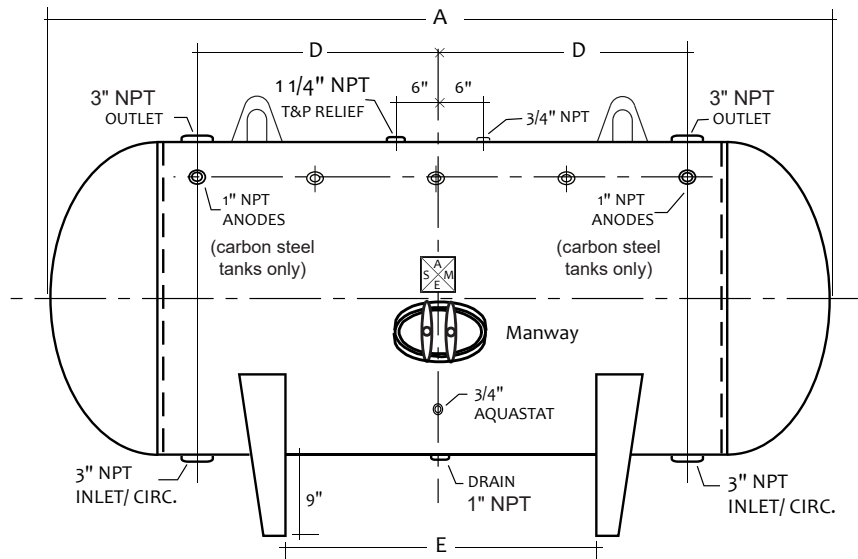

Customer Service and Product Support: 800.900.9276 • Fax 800.559.1583  
 Headquarters: 20 Industrial Way, Rochester, NH, USA 03867 • 603.335.6300 • Fax 603.335.3355  
 9 Brigden Gate, Halton Hills, Ontario, Canada L7G 0A3 • 905.203.0600 • Fax 905.636.0666

[www.Laars.com](http://www.Laars.com)

Litho in U.S.A. © Laars Heating Systems 20-09 Document 4223F

# Tank, Horizontal Bare

STHGB60210    STH2B60210  
 STHDB60210    STH3B60210  
 STHEB60210



## Design

- STHGB Carbon Steel, Glass Lined  
Primed Painted Exterior  
Five-Year Tank Limited Warranty
- STHDB Carbon Steel, Double-Glass Lined  
Primed Painted Exterior  
Ten-Year Tank Limited Warranty
- STHEB Carbon Steel, Epoxy Lining  
Primed Painted Exterior  
One-Year Tank Limited Warranty
- STH2B Duplex Stainless Steel  
Twenty-Five-Year\* Tank Limited Warranty  
\*See warranty sheet for details
- STH3B 316L Stainless Steel  
Ten-Year Tank Limited Warranty

## Submittal Data

Date:

Project #:

Engineer:

Project Name:

Prepared By:

Location:

Bid Date:

Contractor:

Code	ASME Sec IV HLW
Design Pressure	125 psi
Parts Warranty	One Year, Limited
Supports	Saddles
Capacity	2395 Gallons
Nominal Capacity	2570 Gallons
Weight	4172 Lbs.

## Dimensions

Callout	Value	Description
A	210"	Overall Length
B	69"	Overall Height
C	60"	Diameter
D	84"	Circulation
E	162"	Supports
F	52.5"	Support Width

## Options

- 150 PSI Vessel
- Hand Hole
- Optional Fittings / Additional Notes:

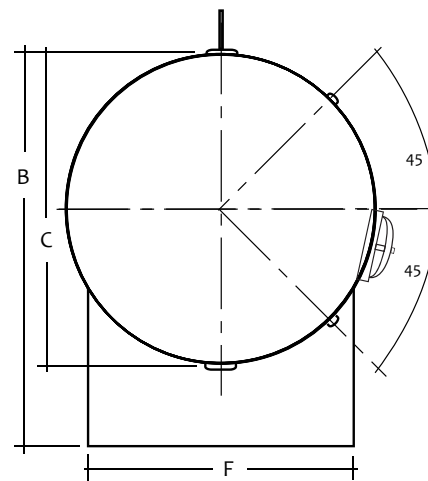
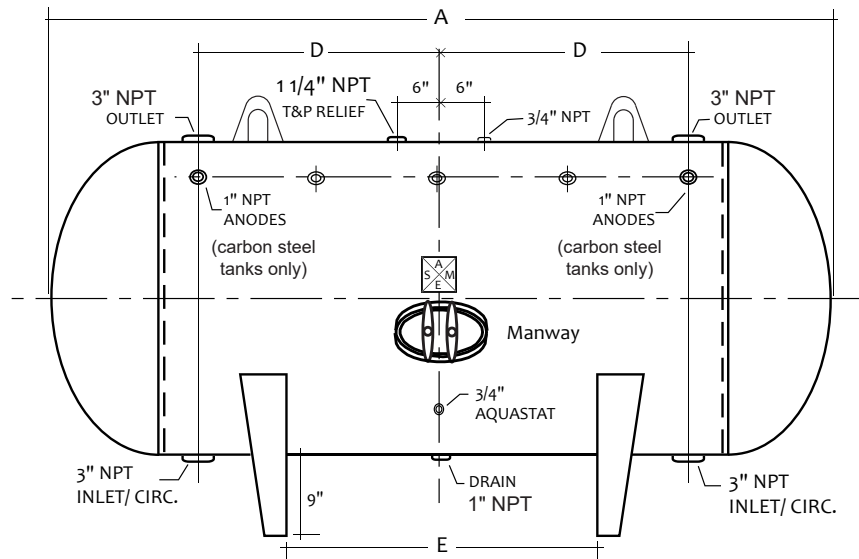

Customer Service and Product Support: 800.900.9276 • Fax 800.559.1583  
 Headquarters: 20 Industrial Way, Rochester, NH, USA 03867 • 603.335.6300 • Fax 603.335.3355  
 9 Brigden Gate, Halton Hills, Ontario, Canada L7G 0A3 • 905.203.0600 • Fax 905.636.0666  
[www.Laars.com](http://www.Laars.com)      Litho in U.S.A. © Laars Heating Systems 20-09 Document 4223F

# Tank, Horizontal Bare

STHGB72100    STH2B72100  
 STHDB72100    STH3B72100  
 STHEB72100



## Design

- STHGB Carbon Steel, Glass Lined  
Primed Painted Exterior  
Five-Year Tank Limited Warranty
- STHDB Carbon Steel, Double-Glass Lined  
Primed Painted Exterior  
Ten-Year Tank Limited Warranty
- STHEB Carbon Steel, Epoxy Lining  
Primed Painted Exterior  
One-Year Tank Limited Warranty
- STH2B Duplex Stainless Steel  
Twenty-Five-Year\* Tank Limited Warranty  
\*See warranty sheet for details
- STH3B 316L Stainless Steel  
Ten-Year Tank Limited Warranty

## Submittal Data

Date:

Project #:

Engineer:

Project Name:

Prepared By:

Location:

Bid Date:

Contractor:

Code	ASME Sec IV HLW
Design Pressure	125 psi
Parts Warranty	One Year, Limited
Supports	Saddles
Capacity	1538 Gallons
Nominal Capacity	1761 Gallons
Weight	2942 Lbs.

## Dimensions

Callout	Value	Description
A	100"	Overall Length
B	81"	Overall Height
C	72"	Diameter
D	26"	Circulation
E	39.5"	Supports
F	63"	Support Width

## Options

- 150 PSI Vessel
- Hand Hole
- Optional Fittings / Additional Notes:

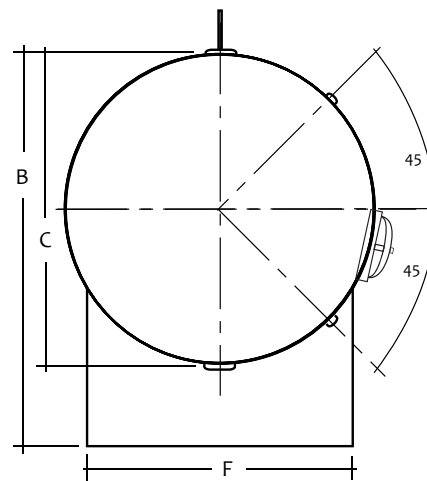
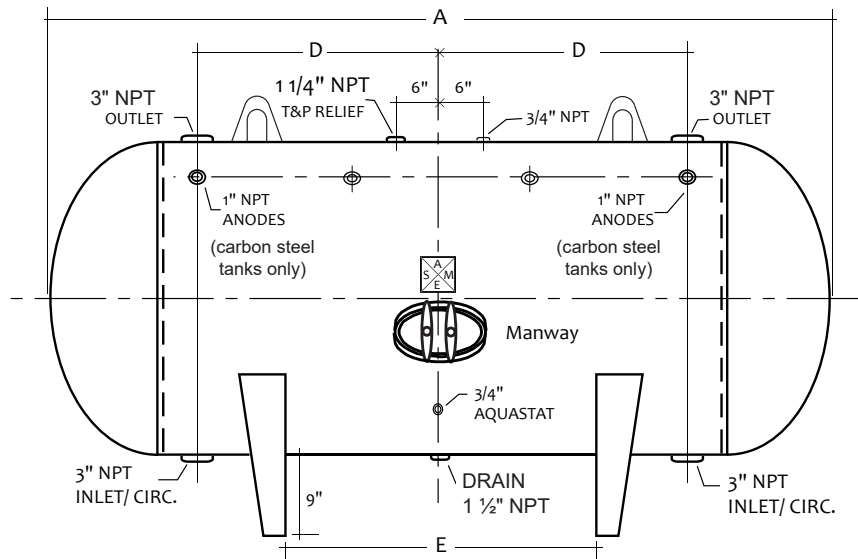

Customer Service and Product Support: 800.900.9276 • Fax 800.559.1583  
 Headquarters: 20 Industrial Way, Rochester, NH, USA 03867 • 603.335.6300 • Fax 603.335.3355  
 9 Brigden Gate, Halton Hills, Ontario, Canada L7G 0A3 • 905.203.0600 • Fax 905.636.0666  
[www.Laars.com](http://www.Laars.com)      Litho in U.S.A. © Laars Heating Systems 20-09 Document 4223F

# Tank, Horizontal Bare

STHGB72117    STH2B72117  
 STHDB72117    STH3B72117  
 STHEB72117



## Design

- STHGB Carbon Steel, Glass Lined  
Primed Painted Exterior  
Five-Year Tank Limited Warranty
- STHDB Carbon Steel, Double-Glass Lined  
Primed Painted Exterior  
Ten-Year Tank Limited Warranty
- STHEB Carbon Steel, Epoxy Lining  
Primed Painted Exterior  
One-Year Tank Limited Warranty
- STH2B Duplex Stainless Steel  
Twenty-Five-Year\* Tank Limited Warranty  
\*See warranty sheet for details
- STH3B 316L Stainless Steel  
Ten-Year Tank Limited Warranty

## Submittal Data

Date:

Project #:

Engineer:

Project Name:

Prepared By:

Location:

Bid Date:

Contractor:

Code	ASME Sec IV HLW
Design Pressure	125 psi
Parts Warranty	One Year, Limited
Supports	Saddles
Capacity	1800 Gallons
Nominal Capacity	2061 Gallons
Weight	3305 Lbs.

## Dimensions

Callout	Value	Description
A	117"	Overall Length
B	81"	Overall Height
C	72"	Diameter
D	34.5"	Circulation
E	46.5"	Supports
F	63"	Support Width

## Options

- 150 PSI Vessel
- Hand Hole
- Optional Fittings / Additional Notes:

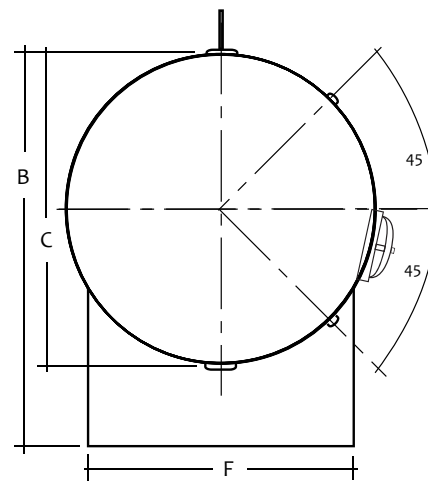
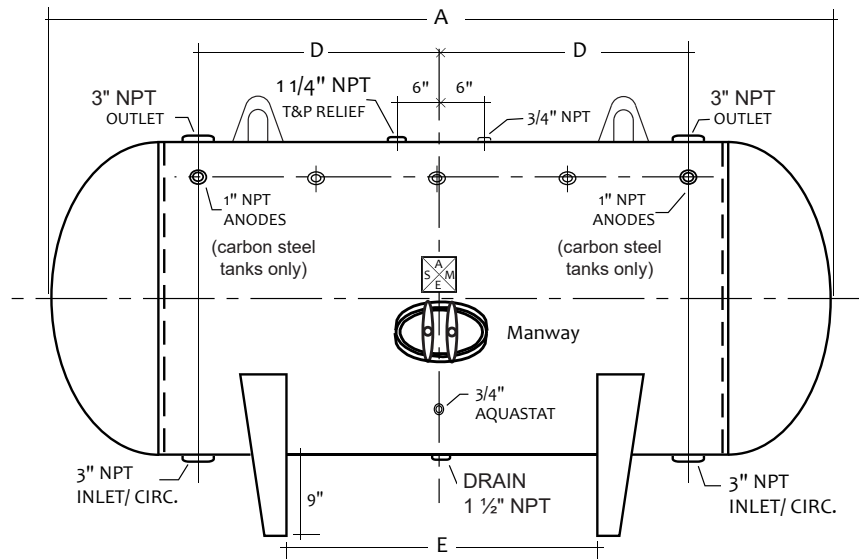



# Tank, Horizontal Bare

STHGB72120    STH2B72120  
 STHDB72120    STH3B72120  
 STHEB72120



## Design

- STHGB Carbon Steel, Glass Lined  
Primed Painted Exterior  
Five-Year Tank Limited Warranty
- STHDB Carbon Steel, Double-Glass Lined  
Primed Painted Exterior  
Ten-Year Tank Limited Warranty
- STHEB Carbon Steel, Epoxy Lining  
Primed Painted Exterior  
One-Year Tank Limited Warranty
- STH2B Duplex Stainless Steel  
Twenty-Five-Year\* Tank Limited Warranty  
\*See warranty sheet for details
- STH3B 316L Stainless Steel  
Ten-Year Tank Limited Warranty

## Submittal Data

Date:

Project #:

Engineer:

Project Name:

Prepared By:

Location:

Bid Date:

Contractor:

Code	ASME Sec IV HLW
Design Pressure	125 psi
Parts Warranty	One Year, Limited
Supports	Saddles
Capacity	1865 Gallons
Nominal Capacity	2115 Gallons
Weight	3369 Lbs.

## Dimensions

Callout	Value	Description
A	120"	Overall Length
B	81"	Overall Height
C	72"	Diameter
D	36"	Circulation
E	49.5"	Supports
F	63"	Support Width

## Options

- 150 PSI Vessel
- Hand Hole
- Optional Fittings / Additional Notes:

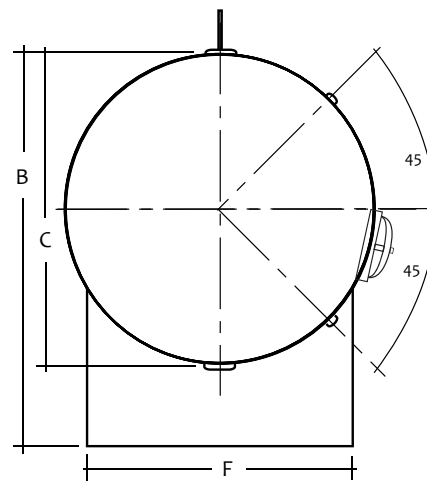
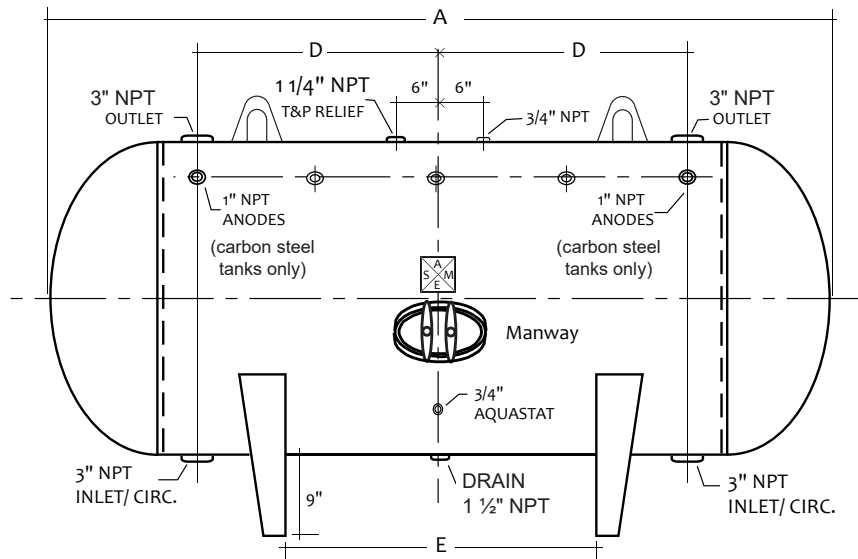

Customer Service and Product Support: 800.900.9276 • Fax 800.559.1583  
 Headquarters: 20 Industrial Way, Rochester, NH, USA 03867 • 603.335.6300 • Fax 603.335.3355  
 9 Brigden Gate, Halton Hills, Ontario, Canada L7G 0A3 • 905.203.0600 • Fax 905.636.0666

[www.Laars.com](http://www.Laars.com)

Litho in U.S.A. © Laars Heating Systems 20-09 Document 4223F

# Tank, Horizontal Bare

STHGB72128    STH2B72128  
 STHDB72128    STH3B72128  
 STHEB72128



## Design

- STHGB Carbon Steel, Glass Lined  
Primed Painted Exterior  
Five-Year Tank Limited Warranty
- STHDB Carbon Steel, Double-Glass Lined  
Primed Painted Exterior  
Ten-Year Tank Limited Warranty
- STHEB Carbon Steel, Epoxy Lining  
Primed Painted Exterior  
One-Year Tank Limited Warranty
- STH2B Duplex Stainless Steel  
Twenty-Five-Year\* Tank Limited Warranty  
\*See warranty sheet for details
- STH3B 316L Stainless Steel  
Ten-Year Tank Limited Warranty

## Submittal Data

Date:

Project #:

Engineer:

Project Name:

Prepared By:

Location:

Bid Date:

Contractor:

Code	ASME Sec IV HLW
Design Pressure	125 psi
Parts Warranty	One Year, Limited
Supports	Saddles
Capacity	2000 Gallons
Nominal Capacity	2256 Gallons
Weight	3540 Lbs.

## Dimensions

Callout	Value	Description
A	128"	Overall Length
B	81"	Overall Height
C	72"	Diameter
D	40"	Circulation
E	57.5"	Supports
F	63"	Support Width

## Options

- 150 PSI Vessel
- Hand Hole
- Optional Fittings / Additional Notes:

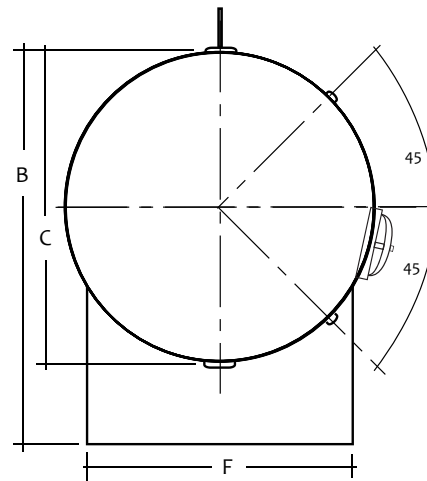
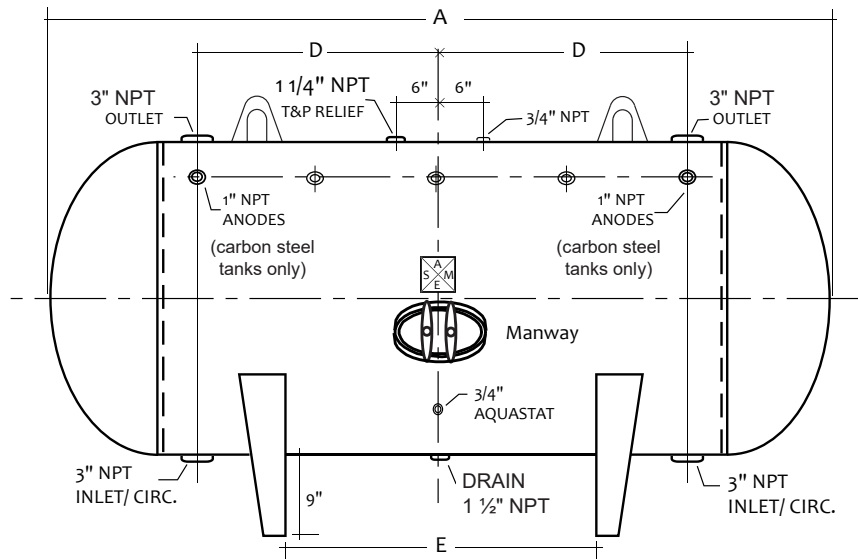

Customer Service and Product Support: 800.900.9276 • Fax 800.559.1583  
 Headquarters: 20 Industrial Way, Rochester, NH, USA 03867 • 603.335.6300 • Fax 603.335.3355  
 9 Brigden Gate, Halton Hills, Ontario, Canada L7G 0A3 • 905.203.0600 • Fax 905.636.0666  
[www.Laars.com](http://www.Laars.com)    Litho in U.S.A. © Laars Heating Systems 20-09 Document 4223F

# Tank, Horizontal Bare

STHGB72144    STH2B72144  
 STHDB72144    STH3B72144  
 STHEB72144



## Design

- STHGB Carbon Steel, Glass Lined  
Primed Painted Exterior  
Five-Year Tank Limited Warranty
- STHDB Carbon Steel, Double-Glass Lined  
Primed Painted Exterior  
Ten-Year Tank Limited Warranty
- STHEB Carbon Steel, Epoxy Lining  
Primed Painted Exterior  
One-Year Tank Limited Warranty
- STH2B Duplex Stainless Steel  
Twenty-Five-Year\* Tank Limited Warranty  
\*See warranty sheet for details
- STH3B 316L Stainless Steel  
Ten-Year Tank Limited Warranty

Date:

Project #:

Engineer:

Prepared By:

Bid Date:

## Submittal Data

Project Name:

Location:

Contractor:

Code	ASME Sec IV HLW
Design Pressure	125 psi
Parts Warranty	One Year, Limited
Supports	Saddles
Capacity	2285 Gallons
Nominal Capacity	2538 Gallons
Weight	3881 Lbs.

## Dimensions

Callout	Value	Description
A	144"	Overall Length
B	81"	Overall Height
C	72"	Diameter
D	48"	Circulation
E	73.5"	Supports
F	63"	Support Width

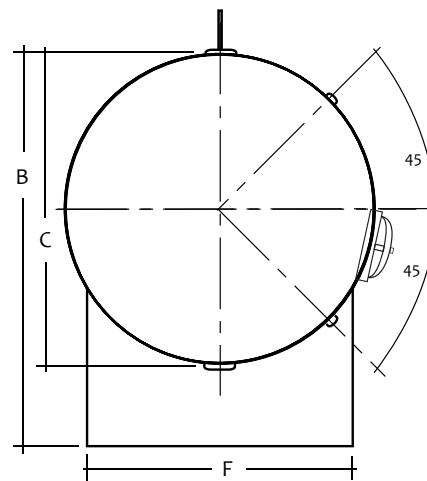
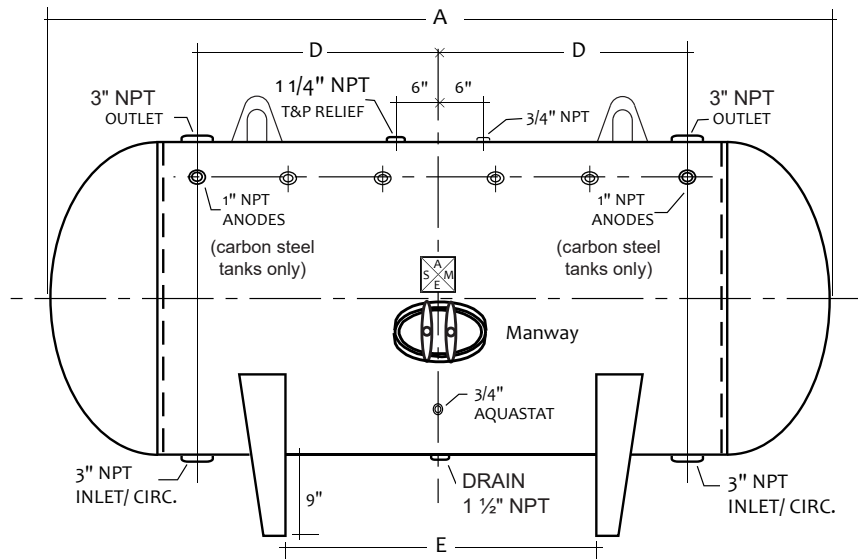

## Options

- 150 PSI Vessel
- Hand Hole
- Optional Fittings / Additional Notes:



Customer Service and Product Support: 800.900.9276 • Fax 800.559.1583  
 Headquarters: 20 Industrial Way, Rochester, NH, USA 03867 • 603.335.6300 • Fax 603.335.3355  
 9 Brigden Gate, Halton Hills, Ontario, Canada L7G 0A3 • 905.203.0600 • Fax 905.636.0666  
[www.Laars.com](http://www.Laars.com)      Litho in U.S.A. © Laars Heating Systems 20-09 Document 4223F

# Tank, Horizontal Bare

STHGB72157    STH2B72157  
 STHDB72157    STH3B72157  
 STHEB72157



## Design

- STHGB Carbon Steel, Glass Lined  
Primed Painted Exterior  
Five-Year Tank Limited Warranty
- STHDB Carbon Steel, Double-Glass Lined  
Primed Painted Exterior  
Ten-Year Tank Limited Warranty
- STHEB Carbon Steel, Epoxy Lining  
Primed Painted Exterior  
One-Year Tank Limited Warranty
- STH2B Duplex Stainless Steel  
Twenty-Five-Year\* Tank Limited Warranty  
\*See warranty sheet for details
- STH3B 316L Stainless Steel  
Ten-Year Tank Limited Warranty

Date:

Project #:

Engineer:

Prepared By:

Bid Date:

## Submittal Data

Project Name:

Location:

Contractor:

Code	ASME Sec IV HLW
Design Pressure	125 psi
Parts Warranty	One Year, Limited
Supports	Saddles
Capacity	2500 Gallons
Nominal Capacity	2765 Gallons
Weight	4105 Lbs.

## Dimensions

Callout	Value	Description
A	157"	Overall Length
B	81"	Overall Height
C	72"	Diameter
D	54.5"	Circulation
E	86.5"	Supports
F	63"	Support Width

## Options

- 150 PSI Vessel
- Hand Hole
- Optional Fittings / Additional Notes:

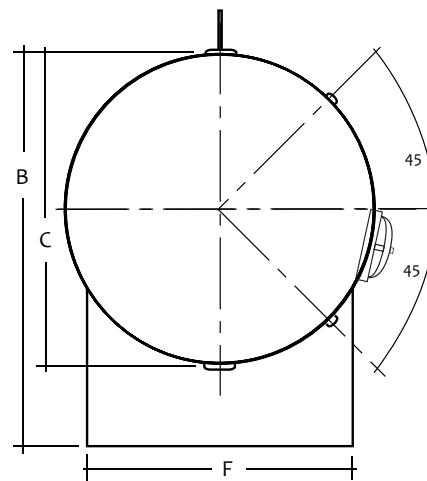
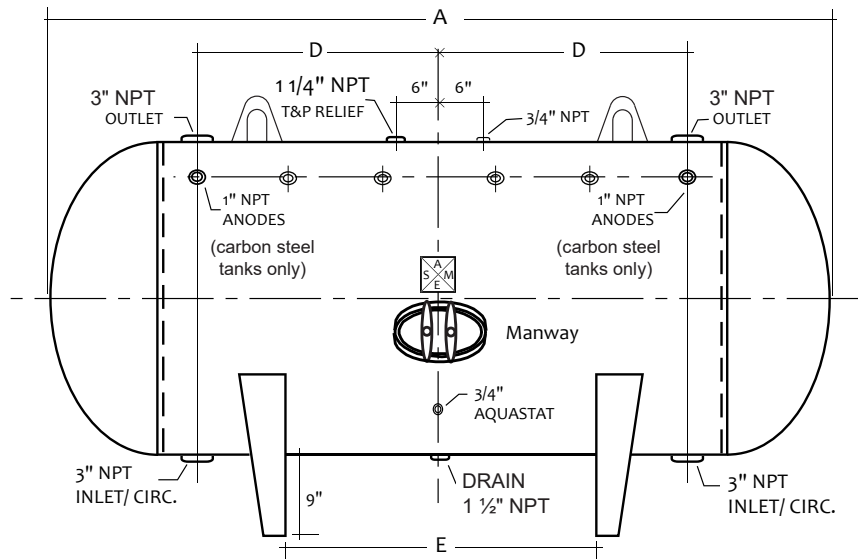

Customer Service and Product Support: 800.900.9276 • Fax 800.559.1583  
 Headquarters: 20 Industrial Way, Rochester, NH, USA 03867 • 603.335.6300 • Fax 603.335.3355  
 9 Brigden Gate, Halton Hills, Ontario, Canada L7G 0A3 • 905.203.0600 • Fax 905.636.0666  
[www.Laars.com](http://www.Laars.com)      Litho in U.S.A. © Laars Heating Systems 20-09 Document 4223F

# Tank, Horizontal Bare

STHGB72168    STH2B72168  
 STHDB72168    STH3B72168  
 STHEB72168



## Design

- STHGB Carbon Steel, Glass Lined  
Primed Painted Exterior  
Five-Year Tank Limited Warranty
- STHDB Carbon Steel, Double-Glass Lined  
Primed Painted Exterior  
Ten-Year Tank Limited Warranty
- STHEB Carbon Steel, Epoxy Lining  
Primed Painted Exterior  
One-Year Tank Limited Warranty
- STH2B Duplex Stainless Steel  
Twenty-Five-Year\* Tank Limited Warranty  
\*See warranty sheet for details
- STH3B 316L Stainless Steel  
Ten-Year Tank Limited Warranty

## Submittal Data

Date:

Project #:

Engineer:

Project Name:

Prepared By:

Location:

Bid Date:

Contractor:

Code	ASME Sec IV HLW
Design Pressure	125 psi
Parts Warranty	One Year, Limited
Supports	Saddles
Capacity	2727 Gallons
Nominal Capacity	2959 Gallons
Weight	4394 Lbs.

## Dimensions

Callout	Value	Description
A	168"	Overall Length
B	81"	Overall Height
C	72"	Diameter
D	60"	Circulation
E	97.5"	Supports
F	63"	Support Width

## Options

- 150 PSI Vessel
- Hand Hole
- Optional Fittings / Additional Notes:

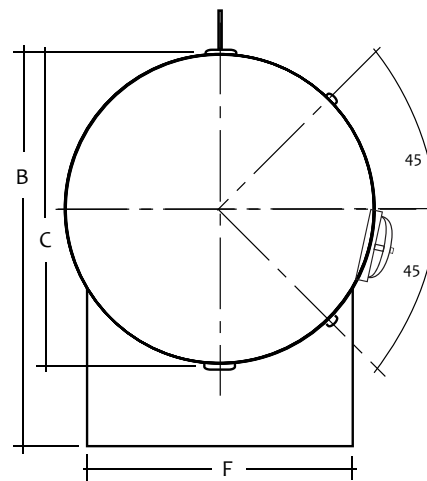
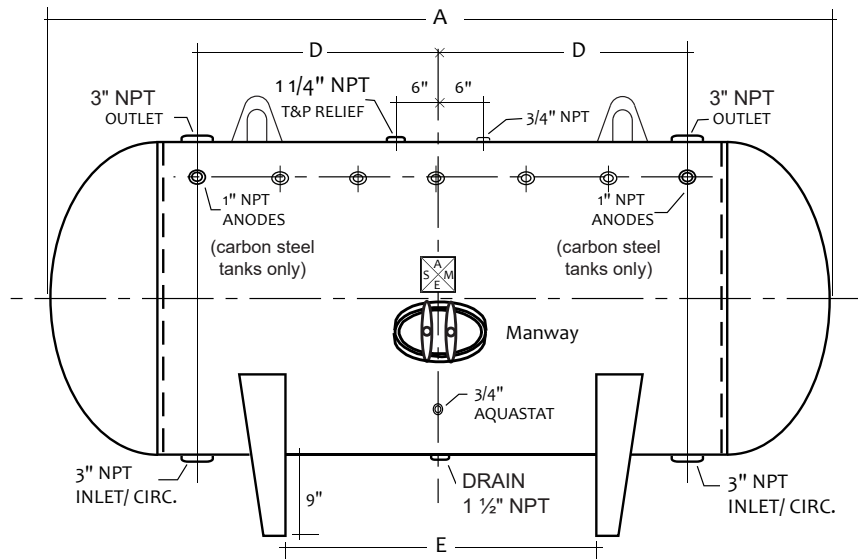

Customer Service and Product Support: 800.900.9276 • Fax 800.559.1583  
 Headquarters: 20 Industrial Way, Rochester, NH, USA 03867 • 603.335.6300 • Fax 603.335.3355  
 9 Brigden Gate, Halton Hills, Ontario, Canada L7G 0A3 • 905.203.0600 • Fax 905.636.0666  
[www.Laars.com](http://www.Laars.com)      Litho in U.S.A. © Laars Heating Systems 20-09 Document 4223F

# Tank, Horizontal Bare

STHGB72192    STH2B72192  
 STHDB72192    STH3B72192  
 STHEB72192



## Design

- STHGB Carbon Steel, Glass Lined  
Primed Painted Exterior  
Five-Year Tank Limited Warranty
- STHDB Carbon Steel, Double-Glass Lined  
Primed Painted Exterior  
Ten-Year Tank Limited Warranty
- STHEB Carbon Steel, Epoxy Lining  
Primed Painted Exterior  
One-Year Tank Limited Warranty
- STH2B Duplex Stainless Steel  
Twenty-Five-Year\* Tank Limited Warranty  
\*See warranty sheet for details
- STH3B 316L Stainless Steel  
Ten-Year Tank Limited Warranty

## Submittal Data

Date:

Project #:

Engineer:

Project Name:

Prepared By:

Location:

Bid Date:

Contractor:

Code	ASME Sec IV HLW
Design Pressure	125 psi
Parts Warranty	One Year, Limited
Supports	Saddles
Capacity	3147 Gallons
Nominal Capacity	3382 Gallons
Weight	4852 Lbs.

## Dimensions

Callout	Value	Description
A	192"	Overall Length
B	81"	Overall Height
C	72"	Diameter
D	72"	Circulation
E	121.5"	Supports
F	63"	Support Width

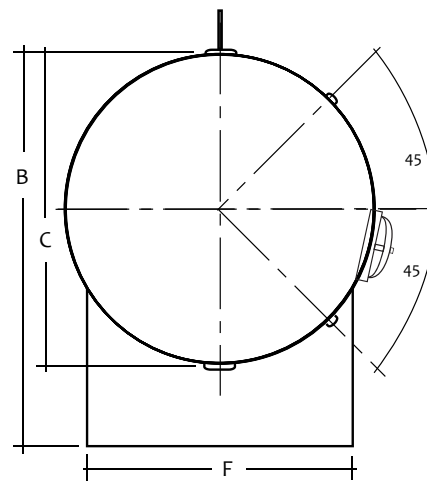
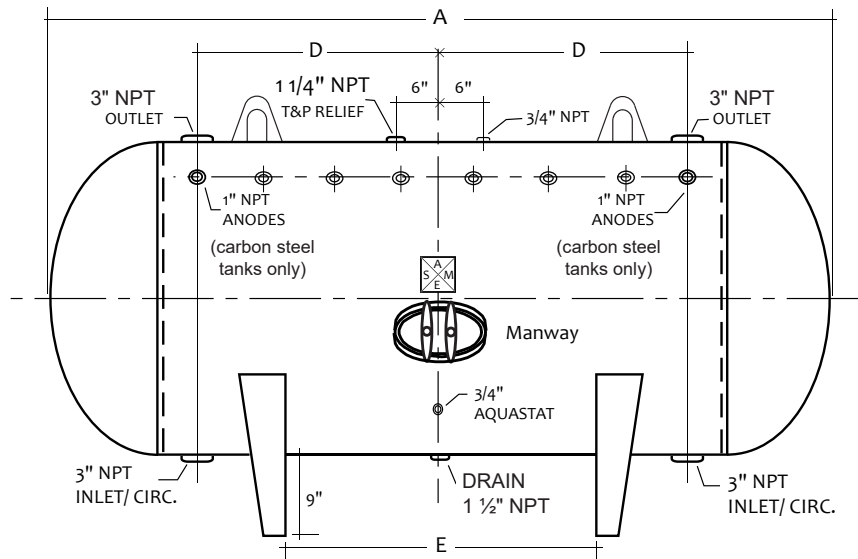

## Options

- 150 PSI Vessel
- Hand Hole
- Optional Fittings / Additional Notes:



Customer Service and Product Support: 800.900.9276 • Fax 800.559.1583  
 Headquarters: 20 Industrial Way, Rochester, NH, USA 03867 • 603.335.6300 • Fax 603.335.3355  
 9 Brigden Gate, Halton Hills, Ontario, Canada L7G 0A3 • 905.203.0600 • Fax 905.636.0666

[www.Laars.com](http://www.Laars.com)

Litho in U.S.A. © Laars Heating Systems 20-09 Document 4223F

# Tank, Horizontal Bare

STHGB72216    STH2B72216  
 STHDB72216    STH3B72216  
 STHEB72216



## Design

- STHGB Carbon Steel, Glass Lined  
Primed Painted Exterior  
Five-Year Tank Limited Warranty
- STHDB Carbon Steel, Double-Glass Lined  
Primed Painted Exterior  
Ten-Year Tank Limited Warranty
- STHEB Carbon Steel, Epoxy Lining  
Primed Painted Exterior  
One-Year Tank Limited Warranty
- STH2B Duplex Stainless Steel  
Twenty-Five-Year\* Tank Limited Warranty  
\*See warranty sheet for details
- STH3B 316L Stainless Steel  
Ten-Year Tank Limited Warranty

## Submittal Data

Date:

Project #:

Engineer:

Project Name:

Prepared By:

Location:

Bid Date:

Contractor:

Code	ASME Sec IV HLW
Design Pressure	125 psi
Parts Warranty	One Year, Limited
Supports	Saddles
Capacity	3567 Gallons
Nominal Capacity	3805 Gallons
Weight	5418 Lbs.

## Dimensions

Callout	Value	Description
A	216"	Overall Length
B	81"	Overall Height
C	72"	Diameter
D	84"	Circulation
E	145.5"	Supports
F	63"	Support Width

## Options

- 150 PSI Vessel
- Hand Hole
- Optional Fittings / Additional Notes:

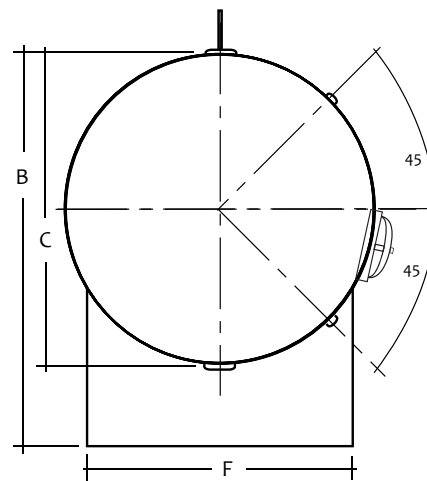
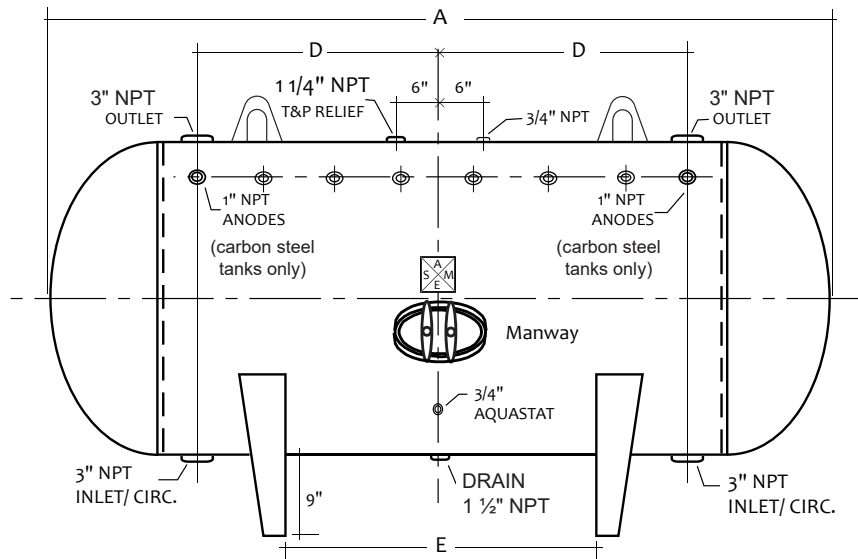

Customer Service and Product Support: 800.900.9276 • Fax 800.559.1583  
 Headquarters: 20 Industrial Way, Rochester, NH, USA 03867 • 603.335.6300 • Fax 603.335.3355  
 9 Brigden Gate, Halton Hills, Ontario, Canada L7G 0A3 • 905.203.0600 • Fax 905.636.0666

[www.Laars.com](http://www.Laars.com)

Litho in U.S.A. © Laars Heating Systems 20-09 Document 4223F

# Tank, Horizontal Bare

STHGB72250    STH2B72250  
 STHDB72250    STH3B72250  
 STHEB72250



## Design

- STHGB Carbon Steel, Glass Lined  
Primed Painted Exterior  
Five-Year Tank Limited Warranty
- STHDB Carbon Steel, Double-Glass Lined  
Primed Painted Exterior  
Ten-Year Tank Limited Warranty
- STHEB Carbon Steel, Epoxy Lining  
Primed Painted Exterior  
One-Year Tank Limited Warranty
- STH2B Duplex Stainless Steel  
Twenty-Five-Year\* Tank Limited Warranty  
\*See warranty sheet for details
- STH3B 316L Stainless Steel  
Ten-Year Tank Limited Warranty

## Submittal Data

Date:

Project #:

Engineer:

Project Name:

Prepared By:

Location:

Bid Date:

Contractor:

Code	ASME Sec IV HLW
Design Pressure	125 psi
Parts Warranty	One Year, Limited
Supports	Saddles
Capacity	4162 Gallons
Nominal Capacity	4404 Gallons
Weight	6144 Lbs.

## Dimensions

Callout	Value	Description
A	250"	Overall Length
B	81"	Overall Height
C	72"	Diameter
D	101"	Circulation
E	179.5"	Supports
F	63"	Support Width

## Options

- 150 PSI Vessel
- Hand Hole
- Optional Fittings / Additional Notes:

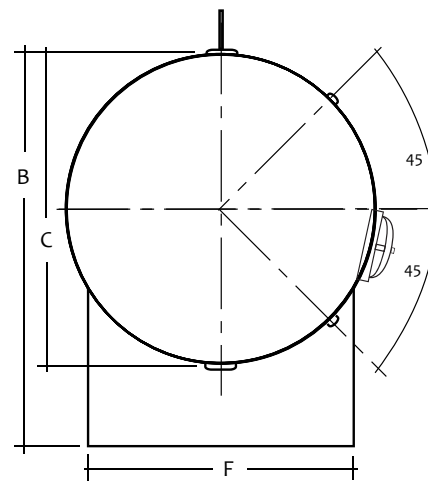
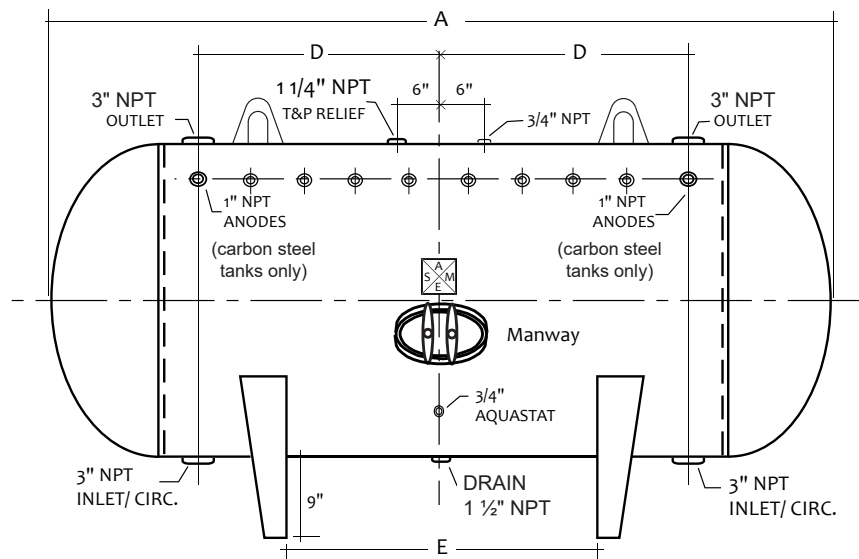

Customer Service and Product Support: 800.900.9276 • Fax 800.559.1583  
 Headquarters: 20 Industrial Way, Rochester, NH, USA 03867 • 603.335.6300 • Fax 603.335.3355  
 9 Brigden Gate, Halton Hills, Ontario, Canada L7G 0A3 • 905.203.0600 • Fax 905.636.0666  
[www.Laars.com](http://www.Laars.com)      Litho in U.S.A. © Laars Heating Systems 20-09 Document 4223F



# Tank, Horizontal Bare

STHGB84121    STH2B84121  
 STHDB84121    STH3B84121  
 STHEB84121



## Design

- STHGB Carbon Steel, Glass Lined  
Primed Painted Exterior  
Five-Year Tank Limited Warranty
- STHDB Carbon Steel, Double-Glass Lined  
Primed Painted Exterior  
Ten-Year Tank Limited Warranty
- STHEB Carbon Steel, Epoxy Lining  
Primed Painted Exterior  
One-Year Tank Limited Warranty
- STH2B Duplex Stainless Steel  
Twenty-Five-Year\* Tank Limited Warranty  
\*See warranty sheet for details
- STH3B 316L Stainless Steel  
Ten-Year Tank Limited Warranty

Date:

Project #:

Engineer:

Prepared By:

Bid Date:

## Submittal Data

Project Name:

Location:

Contractor:

Code	ASME Sec IV HLW
Design Pressure	125 psi
Parts Warranty	One Year, Limited
Supports	Saddles
Capacity	2500 Gallons
Nominal Capacity	2901 Gallons
Weight	4684 Lbs.

## Dimensions

Callout	Value	Description
A	121"	Overall Length
B	93"	Overall Height
C	84"	Diameter
D	32.5"	Circulation
E	38.5"	Supports
F	73"	Support Width

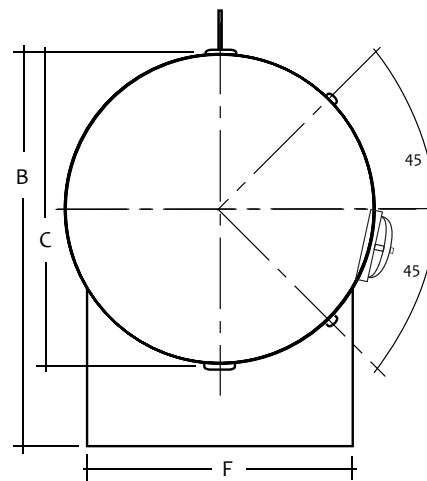
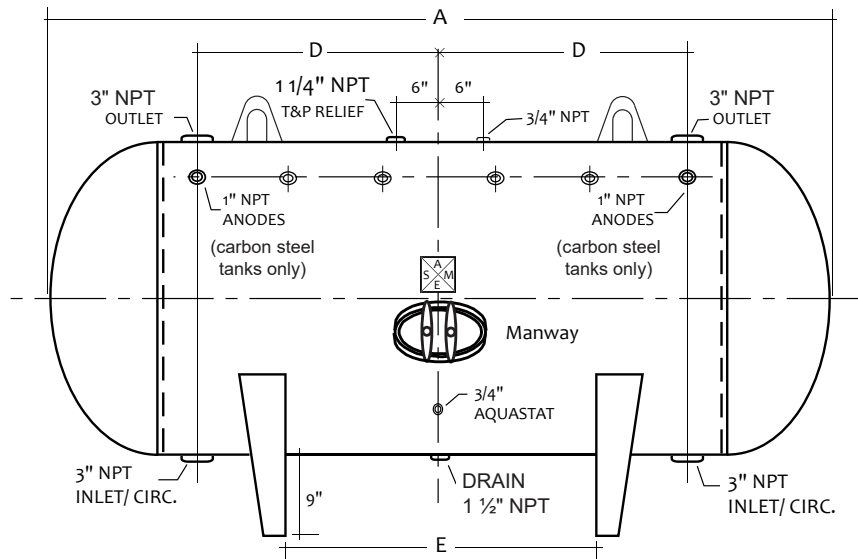

## Options

- 150 PSI Vessel
- Hand Hole
- Optional Fittings / Additional Notes:



**Customer Service and Product Support: 800.900.9276 • Fax 800.559.1583**  
**Headquarters: 20 Industrial Way, Rochester, NH, USA 03867 • 603.335.6300 • Fax 603.335.3355**  
 9 Brigden Gate, Halton Hills, Ontario, Canada L7G 0A3 • 905.203.0600 • Fax 905.636.0666  
[www.Laars.com](http://www.Laars.com)

# Tank, Horizontal Bare

STHGB84138    STH2B84138  
 STHDB84138    STH3B84138  
 STHEB84138



## Design

- STHGB Carbon Steel, Glass Lined  
Primed Painted Exterior  
Five-Year Tank Limited Warranty
- STHDB Carbon Steel, Double-Glass Lined  
Primed Painted Exterior  
Ten-Year Tank Limited Warranty
- STHEB Carbon Steel, Epoxy Lining  
Primed Painted Exterior  
One-Year Tank Limited Warranty
- STH2B Duplex Stainless Steel  
Twenty-Five-Year\* Tank Limited Warranty  
\*See warranty sheet for details
- STH3B 316L Stainless Steel  
Ten-Year Tank Limited Warranty

## Submittal Data

Date:

Project #:

Engineer:

Project Name:

Prepared By:

Location:

Bid Date:

Contractor:

Code	ASME Sec IV HLW
Design Pressure	125 psi
Parts Warranty	One Year, Limited
Supports	Saddles
Capacity	2915 Gallons
Nominal Capacity	3308 Gallons
Weight	5196 Lbs.

## Dimensions

Callout	Value	Description
A	138"	Overall Length
B	93"	Overall Height
C	84"	Diameter
D	41"	Circulation
E	55.5"	Supports
F	73"	Support Width

## Options

- 150 PSI Vessel
- Hand Hole
- Optional Fittings / Additional Notes:

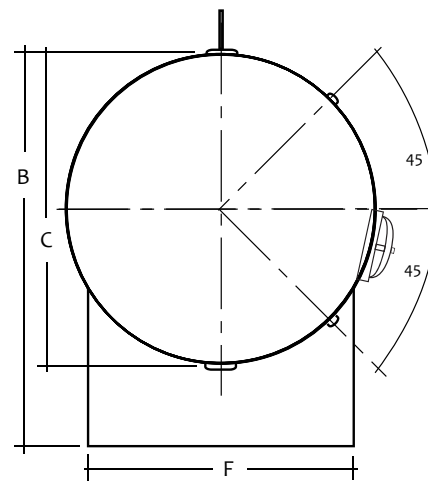
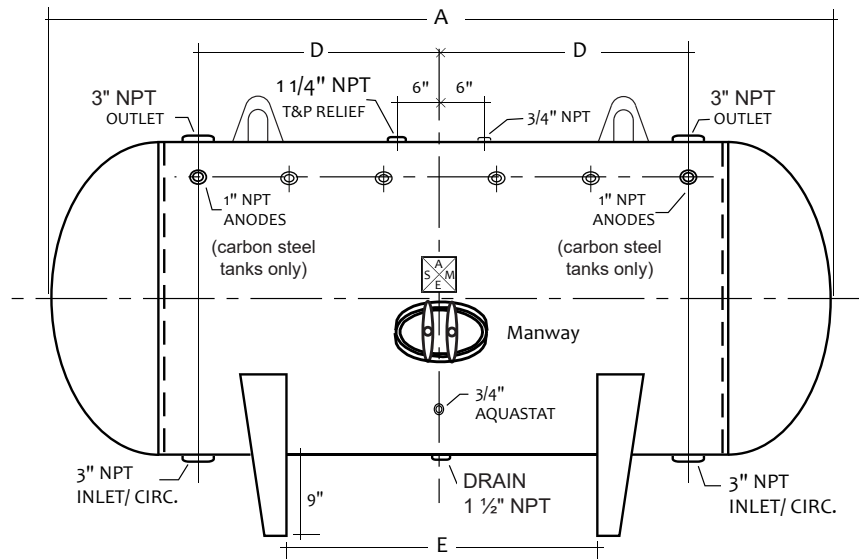

Customer Service and Product Support: 800.900.9276 • Fax 800.559.1583  
 Headquarters: 20 Industrial Way, Rochester, NH, USA 03867 • 603.335.6300 • Fax 603.335.3355  
 9 Brigden Gate, Halton Hills, Ontario, Canada L7G 0A3 • 905.203.0600 • Fax 905.636.0666  
[www.Laars.com](http://www.Laars.com)    Litho in U.S.A. © Laars Heating Systems 20-09 Document 4223F

# Tank, Horizontal Bare

STHGB84162    STH2B84162  
 STHDB84162    STH3B84162  
 STHEB84162



## Design

- STHGB Carbon Steel, Glass Lined  
Primed Painted Exterior  
Five-Year Tank Limited Warranty
- STHDB Carbon Steel, Double-Glass Lined  
Primed Painted Exterior  
Ten-Year Tank Limited Warranty
- STHEB Carbon Steel, Epoxy Lining  
Primed Painted Exterior  
One-Year Tank Limited Warranty
- STH2B Duplex Stainless Steel  
Twenty-Five-Year\* Tank Limited Warranty  
\*See warranty sheet for details
- STH3B 316L Stainless Steel  
Ten-Year Tank Limited Warranty

## Submittal Data

Date:

Project #:

Engineer:

Project Name:

Prepared By:

Location:

Bid Date:

Contractor:

Code	ASME Sec IV HLW
Design Pressure	125 psi
Parts Warranty	One Year, Limited
Supports	Saddles
Capacity	3480 Gallons
Nominal Capacity	3884 Gallons
Weight	5902 Lbs.

## Dimensions

Callout	Value	Description
A	162"	Overall Length
B	93"	Overall Height
C	84"	Diameter
D	53"	Circulation
E	79.5"	Supports
F	73"	Support Width

## Options

- 150 PSI Vessel
- Hand Hole
- Optional Fittings / Additional Notes:

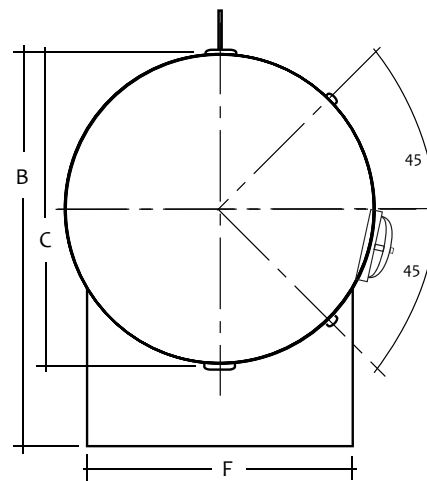
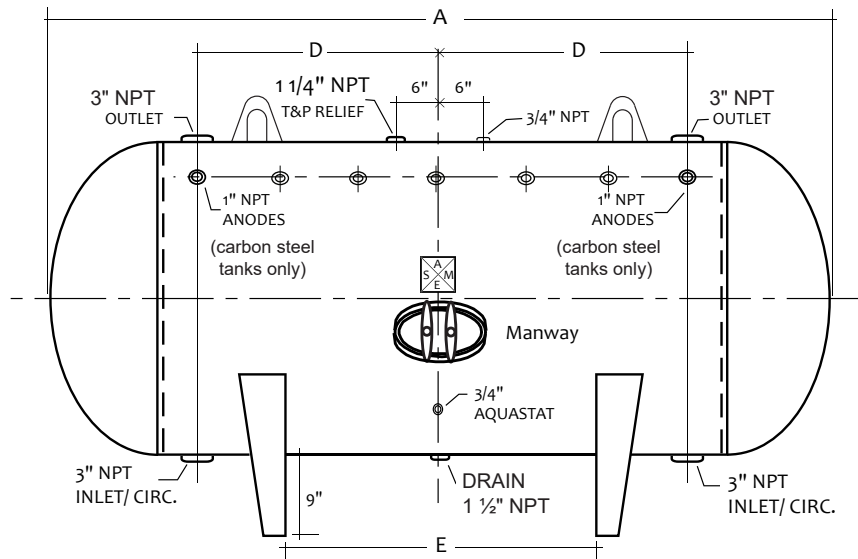

Customer Service and Product Support: 800.900.9276 • Fax 800.559.1583  
 Headquarters: 20 Industrial Way, Rochester, NH, USA 03867 • 603.335.6300 • Fax 603.335.3355  
 9 Brigden Gate, Halton Hills, Ontario, Canada L7G 0A3 • 905.203.0600 • Fax 905.636.0666  
[www.Laars.com](http://www.Laars.com)    Litho in U.S.A. © Laars Heating Systems 20-09 Document 4223F

# Tank, Horizontal Bare

STHGB84186    STH2B84186  
 STHDB84186    STH3B84186  
 STHEB84186



## Design

- STHGB Carbon Steel, Glass Lined  
Primed Painted Exterior  
Five-Year Tank Limited Warranty
- STHDB Carbon Steel, Double-Glass Lined  
Primed Painted Exterior  
Ten-Year Tank Limited Warranty
- STHEB Carbon Steel, Epoxy Lining  
Primed Painted Exterior  
One-Year Tank Limited Warranty
- STH2B Duplex Stainless Steel  
Twenty-Five-Year\* Tank Limited Warranty  
\*See warranty sheet for details
- STH3B 316L Stainless Steel  
Ten-Year Tank Limited Warranty

## Submittal Data

Date:

Project #:

Engineer:

Project Name:

Prepared By:

Location:

Bid Date:

Contractor:

Code	ASME Sec IV HLW
Design Pressure	125 psi
Parts Warranty	One Year, Limited
Supports	Saddles
Capacity	4045 Gallons
Nominal Capacity	4459 Gallons
Weight	6614 Lbs.

## Dimensions

Callout	Value	Description
A	186"	Overall Length
B	93"	Overall Height
C	84"	Diameter
D	65"	Circulation
E	103.5"	Supports
F	73"	Support Width

## Options

- 150 PSI Vessel
- Hand Hole
- Optional Fittings / Additional Notes:

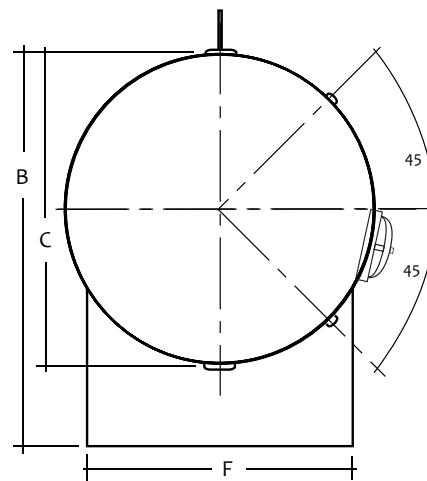
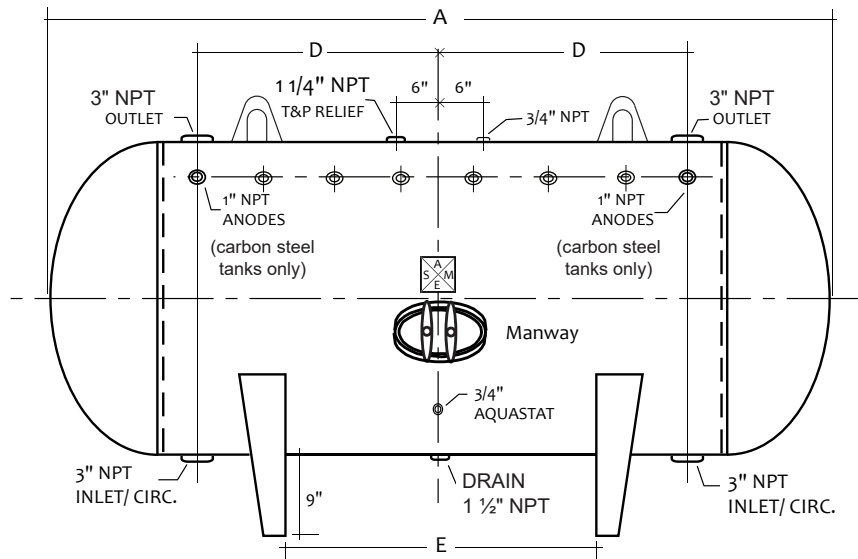

Customer Service and Product Support: 800.900.9276 • Fax 800.559.1583  
 Headquarters: 20 Industrial Way, Rochester, NH, USA 03867 • 603.335.6300 • Fax 603.335.3355  
 9 Brigden Gate, Halton Hills, Ontario, Canada L7G 0A3 • 905.203.0600 • Fax 905.636.0666

[www.Laars.com](http://www.Laars.com)

Litho in U.S.A. © Laars Heating Systems 20-09 Document 4223F

# Tank, Horizontal Bare

STHGB84210    STH2B84210  
 STHDB84210    STH3B84210  
 STHEB84210



## Design

- STHGB Carbon Steel, Glass Lined  
Primed Painted Exterior  
Five-Year Tank Limited Warranty
- STHDB Carbon Steel, Double-Glass Lined  
Primed Painted Exterior  
Ten-Year Tank Limited Warranty
- STHEB Carbon Steel, Epoxy Lining  
Primed Painted Exterior  
One-Year Tank Limited Warranty
- STH2B Duplex Stainless Steel  
Twenty-Five-Year\* Tank Limited Warranty  
\*See warranty sheet for details
- STH3B 316L Stainless Steel  
Ten-Year Tank Limited Warranty

## Submittal Data

Date:

Project #:

Engineer:

Project Name:

Prepared By:

Location:

Bid Date:

Contractor:

Code	ASME Sec IV HLW
Design Pressure	125 psi
Parts Warranty	One Year, Limited
Supports	Saddles
Capacity	4610 Gallons
Nominal Capacity	5038 Gallons
Weight	7327 Lbs.

## Dimensions

Callout	Value	Description
A	210"	Overall Length
B	93"	Overall Height
C	84"	Diameter
D	77"	Circulation
E	127.5"	Supports
F	73"	Support Width

## Options

- 150 PSI Vessel
- Hand Hole
- Optional Fittings / Additional Notes:

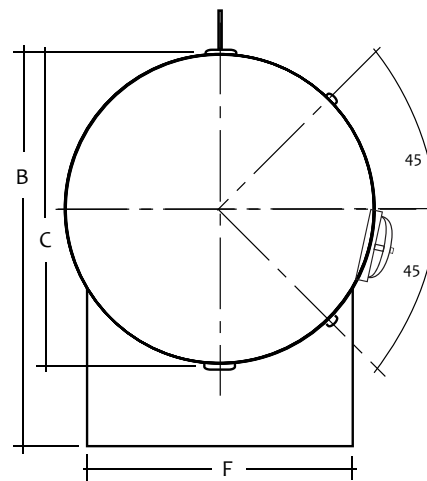
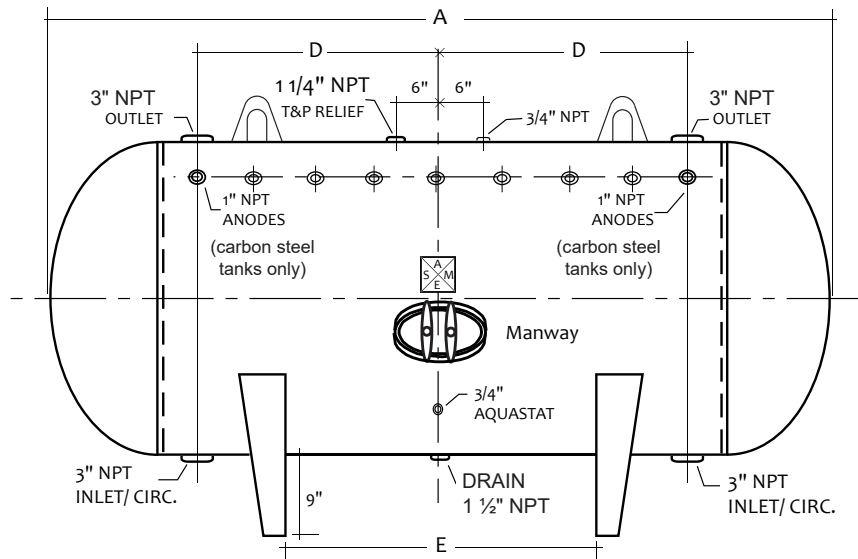

Customer Service and Product Support: 800.900.9276 • Fax 800.559.1583  
 Headquarters: 20 Industrial Way, Rochester, NH, USA 03867 • 603.335.6300 • Fax 603.335.3355  
 9 Brigden Gate, Halton Hills, Ontario, Canada L7G 0A3 • 905.203.0600 • Fax 905.636.0666  
[www.Laars.com](http://www.Laars.com)    Litho in U.S.A. © Laars Heating Systems 20-09 Document 4223F

# Tank, Horizontal Bare

STHGB84256    STH2B84256  
 STHDB84256    STH3B84256  
 STHEB84256



## Design

- STHGB Carbon Steel, Glass Lined  
Primed Painted Exterior  
Five-Year Tank Limited Warranty
- STHDB Carbon Steel, Double-Glass Lined  
Primed Painted Exterior  
Ten-Year Tank Limited Warranty
- STHEB Carbon Steel, Epoxy Lining  
Primed Painted Exterior  
One-Year Tank Limited Warranty
- STH2B Duplex Stainless Steel  
Twenty-Five-Year\* Tank Limited Warranty  
\*See warranty sheet for details
- STH3B 316L Stainless Steel  
Ten-Year Tank Limited Warranty

## Submittal Data

Date:

Project #:

Engineer:

Project Name:

Prepared By:

Location:

Bid Date:

Contractor:

Code	ASME Sec IV HLW
Design Pressure	125 psi
Parts Warranty	One Year, Limited
Supports	Saddles
Capacity	5695 Gallons
Nominal Capacity	6138 Gallons
Weight	8693 Lbs.

## Dimensions

Callout	Value	Description
A	256"	Overall Length
B	93"	Overall Height
C	84"	Diameter
D	100"	Circulation
E	173.5"	Supports
F	73"	Support Width

## Options

- 150 PSI Vessel
- Hand Hole
- Optional Fittings / Additional Notes:

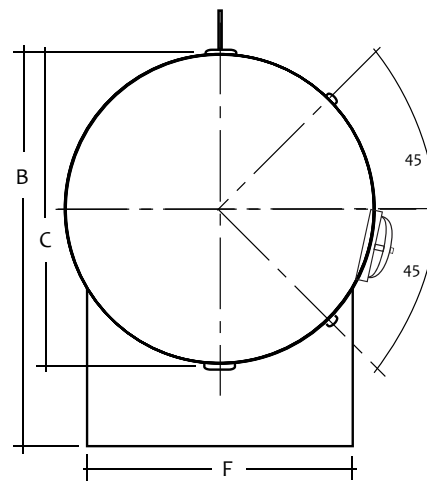
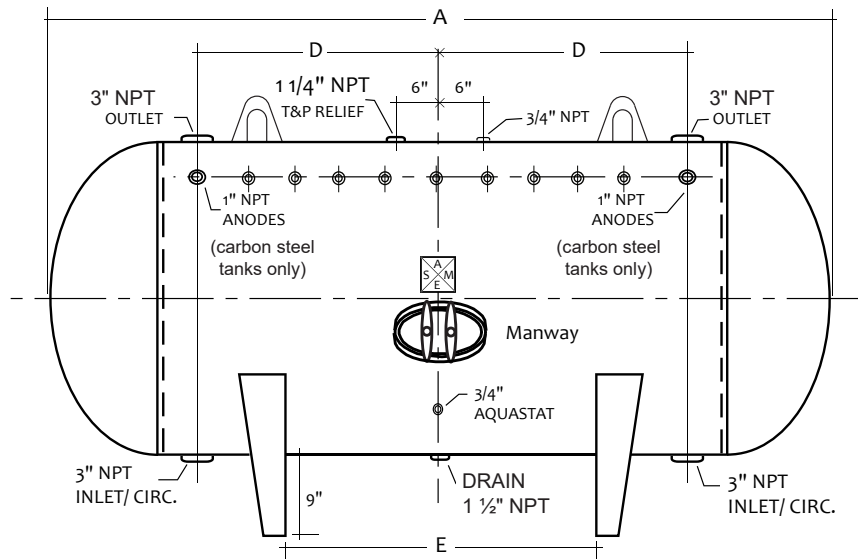

Customer Service and Product Support: 800.900.9276 • Fax 800.559.1583  
 Headquarters: 20 Industrial Way, Rochester, NH, USA 03867 • 603.335.6300 • Fax 603.335.3355  
 9 Brigden Gate, Halton Hills, Ontario, Canada L7G 0A3 • 905.203.0600 • Fax 905.636.0666  
[www.Laars.com](http://www.Laars.com)      Litho in U.S.A. © Laars Heating Systems 20-09 Document 4223F