

NEOTHERM[®] XTR

Condensing Boiler or
Volume Water Heater



- ✓ Laars Linc[®] Advanced Control
- ✓ 6 Models: 399-1500 MBH
- ✓ 96% Thermal Efficiency
- ✓ 10:1 Turndown
- ✓ 150 Equivalent Feet of Vent
- ✓ Low Pressure Drop Heat Exchanger

Commercial High Efficiency
XTR Ordinary Performance

LAARS[®] 
Heating Systems Company
Built to be the Best[®]

NEOTHERM® XTR

DESIGNED FOR VERSATILITY

Since our beginning as Laars Engineering in 1948, Laars has embodied innovation and advancement in heating technology. We have built upon our technology over the past seventy-five plus years to ensure Laars products meet the demands of today's discerning customer.

The Laars tradition continues in the NeoTherm XTR boiler and water heater design, striking the right balance of advanced technology, contractor focused features, and the robustness needed to perform year in and year out.



HIGH PERFORMANCE HEATING

- 96% thermal efficiency
- 10:1 turndown
- Robust stainless steel, low pressure drop heat exchanger
- Efficient dual-venturi combustion system



FLEXIBLE SYSTEM INTEGRATION

- Laars Linc® icon-driven touchscreen control
- VARI-PRIME® control logic
- Cascade up to 8 units
- BMS compatible



VERSATILE INSTALLATION OPTIONS

- Available in 399, 500, 650, 800, 999, and 1500 MBH sizes
- Up to 150 equivalent feet of vent
- Category II or IV venting
- Common vent multiple units
- Outdoor kit available
- Front access to major components supports closely-spaced multi-unit installations



WORLD CLASS SUPPORT

- Technical phone support – 1-800-900-9276
- Regional in-field service support
- Factory and regional hands-on training available
- Online training tools and videos
- Revit, MasterSpec, and RightSize DHW sizing tool



Check out our
Product Videos



BOILER OR VOLUME WATER HEATER

ENGINEERED FOR XTR-ORDINARY PERFORMANCE

The all new Laars NeoTherm XTR boiler and volume water heater delivers powerful performance and rugged reliability that you can count on. Under the hood is a next generation heat exchanger powered by the Laars X-Trac™ Dual Venturi Combustion System that delivers superior operation, year in and year out - whether its for replacement work or a new install.

A top connection piping layout and front access to major components allow for easier installation of multiple boilers or locations with minimal clearances.

Bringing this all together, is the powerful Laars Linc® control system that manages the simplest to most complex application through an intuitive to use, yet powerful feature set.

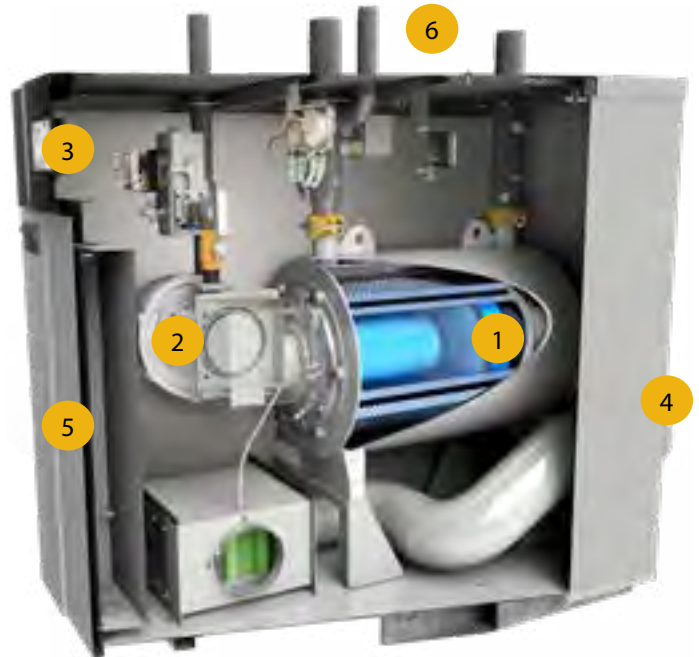

- 1** Stainless-Steel, Low-Pressure Drop, Water Tube Heat Exchanger
 - Smaller pumps required vs. legacy designs, reducing installation costs and minimizing electrical use
 - Stainless steel construction, ideal for long life condensing operation
- 2** Laars X-Trac™ Combustion System with 10:1 Turndown
- 3** Powerful Laars Linc® Touchscreen Control Interface
- 4** Flexible Venting Options:
 - Exhaust vent connection adapts to stainless, polypropylene and CPVC
 - Common vent multiple units
 - 150 ft of equivalent vent
- 5** Easy Access Top, Front, And Side Panels
 - Major components can be accessed from the front of the boiler
- 6** Water and Gas Piping Easily Accessible from Top of Unit



Rebates Available!
Don't forget to submit for your rebate today!

Find Rebates &
Tax credits at
LAARS.COM



LAARS LINC[®]

Powerful control logic is easily managed via icon driven, touch screen technology. The result is an intuitive to use control system with the intelligence to manage installations from the simple to the complex.

ADVANCED EASE OF USE FUNCTIONALITY:

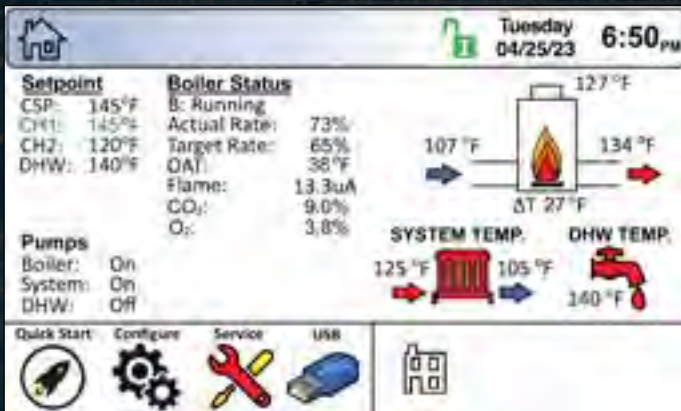

- **HOME SCREEN BOILER STATUS:** The home screen shows the operational status of the boiler; all set points, status of each pump, and boiler run status.
- **QUICK START CONFIGURATOR:** Simply touch the "Quick Start" icon on the home screen to access the most commonly-used parameters for systems that don't require advanced set up.
- **USB DATA CONNECTION:** The USB connection allows for easy transfer of parameter sets from one boiler to another and for the boiler's history data to be transferred to a USB memory device.
- **MULTIPLE PUMP CONTROL:** System pump, boiler pump and domestic water pump operation, each with time delay.
- **VARI-PRIME[®] PUMP CONTROL:** Controls a variable speed boiler pump to maintain a fixed, user-selectable, boiler temperature rise - maximizing total installed efficiency.
- **LAARS LINC CONTROL-TO-DISPLAY HANDSHAKE:** If for any reason a display or control board needs to be replaced, the parameter set is automatically transferred from the remaining display or control board to the replaced component. Parameters are stored on both the display and control to auto populate either one!
- **INTELLIGENT REDUNDANCY:** Laars Linc cascade logic includes a built-in redundancy; via either a lag unit's internal setpoint, or a configurable redundant leader. A bank of boilers will continue to operate even if the leader control goes down, keeping buildings warm and hot water flowing!
- **AUTO CONFIGURING CASCADE:** Up to 8 units can be automatically configured by simply connecting the controls and selecting the lead boiler. The intelligence of Laars Linc takes over to auto configure the remaining follower boilers. No need to register each follower!
- **BacNET MSTP AND MODBUS RTU ON BOARD**

LAARS X-TRAC™ Combustion Technology

The key to Laars X-Trac™ high performance combustion system lies within two independently controlled, air and gas injection ports that result in a wide, responsive control range. When full capacity is needed the dual air flow paths and gas injection ports open wide resulting in maximum output. However, when reduced outputs are required, the high range input air and gas injection paths close allowing for precise control at the lower turndown levels. This is all managed via a responsive pneumatic feedback system to the gas valve, ensuring accurate control across the entire 10:1 operational range.

VARI-PRIME® Boiler Pump Flow Control

Laars Vari-Prime flow control allows the NeoTherm XTR boiler to control a variable speed boiler pump to maintain a fixed, user-selectable, boiler temperature rise - maximizing total installed efficiency. Boiler pumps are often sized for the maximum flow that a boiler needs, but boilers rarely operate at maximum capacity. A pump's power consumption can drop by as much as 50% with only a 20% reduction in speed. The payback for the variable speed pump, when installed with a Vari-Prime equipped NeoTherm, setup can be realized in as little as one year!

Typical Pump Power Savings via Vari-Prime

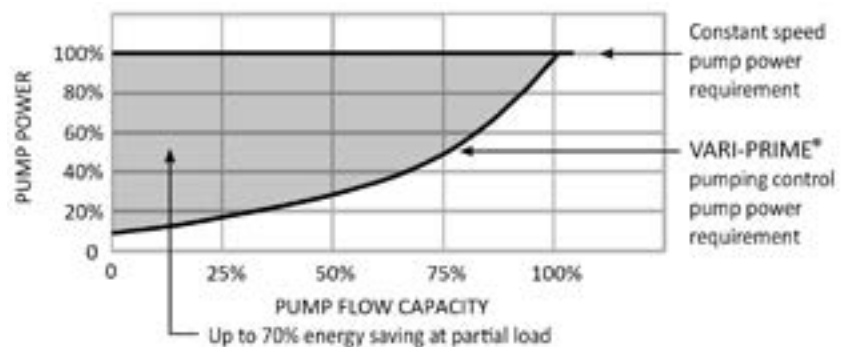

NeoTherm® XTR Venting Versatility

The NeoTherm XTR has you covered for all your venting challenges!

- 150 equivalent feet of air intake or exhaust vent length each
- Common vent multiple units*
- Material selections of PVC, CPVC, Polypropylene, or Stainless Steel
- Horizontal or vertical orientations
- Unbalanced vent vs. air intake lengths
- Intake air and exhaust from different pressure zones, i.e. different sides of building or one vertical leg and one horizontal leg, or a mixture of both



*Common vent sizing to be done by third party using flow and pressure data provided by Laars

SIZING DATA

Model	Min Input Rate		Max Input Rate		Min Output Rate		Max Output Rate		AHRI Certified			Product Weight		Shipping Weight	
									Thermal Efficiency		Combustion Efficiency				
	MBH	kw	MBH	kw	MBH	kw	MBH	kw	Boiler (%)	VWH (%)	Boiler (%)	lbs	kg	lbs	kg
399	39.9	11.7	399	117	38.6	11.3	386	113	96.7	98%	98.5	391	178	508	231
500	50	14.7	500	147	48.3	14.2	483	142	96.6	97%	98.4	401	182	518	235
650	65	19	650	191	62.7	18.4	627	184	96.5	97%	98.2	471	214	597	271
800	80	23.4	800	235	77.1	22.6	771	226	96.4	97%	98.0	492	224	618	281
999	99.9	29.3	999	293	96.2	28.2	962	282	96.3	97%	97.7	542	246	679	309
1500	150	44	1500	440	144.0	42.2	1440	422	96.0	99%	97.0	620	282	757	344

BOILER WATER FLOW REQUIREMENTS

Model	Temperature Rise (°F)									
	20		30		40		50		60	
	Flow	H/L	Flow	H/L	Flow	H/L	Flow	H/L	Flow	H/L
	gpm	ft	gpm	ft	gpm	ft	gpm	ft	gpm	ft
399	38	10.8	26	4.8	19	2.7	15	1.8	13	1.2
500	48	12.0	32	5.3	24	2.9	19	1.9	16	1.3
650	62	12.2	42	5.4	31	3.0	25	1.9	21	1.3
800	77	13.3	51	5.9	38	3.3	31	2.2	26	1.5
999	96	15.0	64	6.8	48	3.9	38	2.5	32	1.8
1500	144	35.2	96	15.7	72	8.8	58	5.7	48	4.0

Model	Temperature Rise (°C)									
	11		17		22		28		33	
	Flow	H/L	Flow	H/L	Flow	H/L	Flow	H/L	Flow	H/L
	lpm	m	lpm	m	lpm	m	lpm	m	lpm	m
399	145	3.3	97	1.5	72	0.8	58	0.5	48	0.4
500	182	3.7	121	1.6	91	0.9	73	0.6	61	0.4
650	236	3.7	157	1.6	118	0.9	94	0.6	79	0.4
800	291	4.1	194	1.8	145	1.0	116	0.7	97	0.5
999	363	4.6	242	2.1	182	1.2	145	0.8	121	0.5
1500	545	10.7	363	4.8	273	2.7	218	1.7	182	1.2

WATER HEATER WATER FLOW REQUIREMENTS

Model	Water Hardness 5 - 12 gpg			Water Hardness 12 - 15 gpg		
	Flow	H/L	Delta-T	Flow	H/L	Delta-T
	gpm	ft	°F	gpm	ft	°F
399	31	7.0	25	41	12.3	20
500	37	7.0	25	49	12.6	20
650	49	7.5	25	66	13.4	20
800	61	8.5	25	82	15.1	20
999	74	8.9	25	98	15.7	20
1500	80	10.8	36	106	19.2	27

Model	Water Hardness 5 - 12 gpg			Water Hardness 12 - 15 gpg		
	Flow	H/L	Delta-T	Flow	H/L	Delta-T
	lpm	m	°C	lpm	m	°C
399	116	2.1	14	155	3.7	11
500	139	2.1	14	186	3.8	11
650	186	2.3	14	248	4.1	11
800	232	2.6	14	310	4.6	11
999	279	2.7	14	372	4.8	11
1500	302	3.3	20	403	5.9	15

WATER HEATER RECOVERY DATA

Model	Water Hardness 5 - 12 gpg																	
	40°F	22°C	50°F	28°C	60°F	33°C	70°F	39°C	80°F	44°C	90°F	50°C	100°F	56°C	120°F	67°C	140°F	78°C
	gph	lph	gph	lph	gph	lph	gph	lph	gph	lph	gph	lph	gph	lph	gph	lph	gph	lph
399	1149	450	919	3480	766	2900	657	2486	575	2175	511	1933	460	1740	383	1450	328	1243
500	1440	5451	1152	4361	960	3634	823	3115	720	2725	640	2423	576	2180	480	1817	411	1557
650	1872	7086	1498	5669	1248	4724	1070	4049	936	3543	832	3149	749	2835	624	2362	535	2025
800	2304	8722	1843	6977	1536	5814	1317	4984	1152	4361	1024	3876	922	3489	768	2907	658	2492
999	2877	10891	2302	8713	1918	7261	1644	6223	1439	5446	1279	4840	1151	4356	959	3630	822	3112
1500	4320	16353	3456	13082	2880	10902	2469	9345	2160	8176	1920	7268	1728	6541	1440	5451	1234	4672

VENTING DATA

Model	Air Intake			Vent			
	Diameter (in)	Min. Equivalent Length (ft)	Max. Equivalent Length (ft)	Category IV Diameter (in)	Category IV Min. Equivalent Length (ft)	Category IV Max. Equivalent Length (ft)	Typical* Category II Diameter (in)
399	4	0	150	4	10	150	12
500	4	0	150	4	10	150	12
650	6	0	150	6	10	150	12
800	6	0	150	6	10	150	12
999	6	0	150	6	10	150	12
1500	8	0	150	8	10	150	12

Equivalent Length: Add 5 feet for each 90° elbow up to the first 6. If more than 6 are needed in either the vent or air intake, or any 45° elbows are required, reference the installation manual.

DIMENSIONAL DATA

Model	Dimensions											
	A		B		C		D		E		Gas Conn.	Water Conn.
	(in)	(cm)	(in)	(cm)	(in)	(cm)	(in)	(cm)	(in)	(cm)		
399	47 ¼	120	41 ½	105	23 ¼	59	12	31	5	13	1	2
500	47 ¼	120	41 ½	105	24 ½	62	13 ½	34	5	13	1	2
650	54 ¼	138	48 ½	123	31 ¼	79	17 ¾	45	3 ¼	8	1 ¼	2
800	54 ¼	138	48 ½	123	34	86	20 ¾	53	3 ¼	8	1 ¼	2
999	57 ¾	147	52	132	35	89	25 ½	65	4	10	1 ½	2 ½
1500	66 ¾	169	61	155	42 ½	108	33	84	4	10	1 ½	2 ½

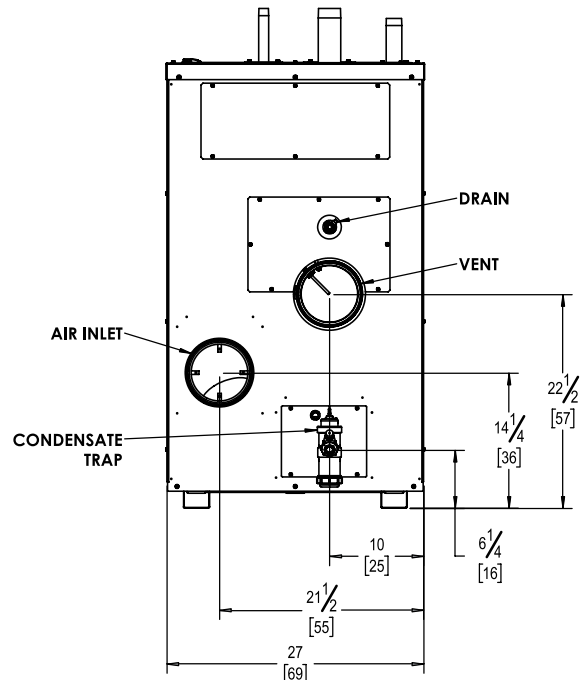
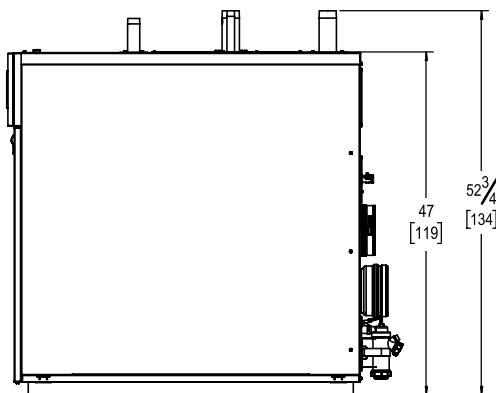
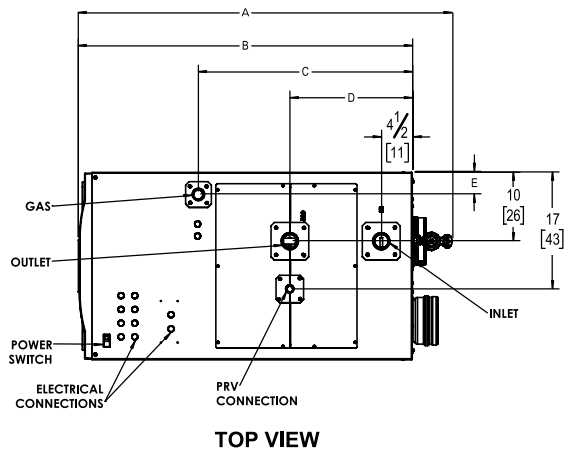



WWW.LAARS.COM



Browse Laars
NeoTherm XTR



Customer Service and Product Support: 800.900.9276 • Fax 800.559.1583
Headquarters: 20 Industrial Way, Rochester, NH 03867 • 603.335.6300 • Fax 603.335.3355
9 Brigden Gate, Halton Hills, Ontario, Canada, L7G 0A3 • 905.203.0600 • Fax 905.636.0666
www.LAARS.com