

# Turbo Ultra High Efficiency Commercial Gas Water Heater

## Features

- **ENERGY STAR<sup>®</sup> Certified.**
  - **Thermal Efficiency up to 97%**—Ultra High Efficiency results in less fuel consumption and greater hot water recovery.
- **Modulating Down-Fired Premix Power Burner**—A self compensating negative regulation system automatically increases or decreases fuel flow when a change in combustion air is detected. This provides the range for optimum combustion and efficiency with up to 6:1 Turn Down Ratio.
  - **High Altitude SKUs Available**—For installs between 2000-7800 ft. (610-2,377m) above sea level.
- **Three-Pass Fire Tube Heat Exchanger System**—Keeps the hot combustion gases moving at a high velocity. Turbo flues within the heat exchanger create superior conduction paths for heat transfer and turbulate the combustion gases to heat water faster and more efficiently.
- **Advanced Controls**—Intelligent proven design combines temperature control, diagnostic codes, and system ignition functions with a digital LCD display.
  - **BMS Integration**—Modbus & BACnet<sup>®</sup> compatible via gateway kit.
- **Enamel Glass with Microban<sup>®</sup>**—An exclusively engineered enamel formula that provides superior tank protection from the corrosive effects of water; and with Microban<sup>®</sup> antimicrobial product protection to help prevent the growth of bacteria, mold and mildew on the surface of the tank lining.
- **Protective Powered Anodes**—Two anode rods provide added protection against corrosion for long-term, trouble-free service.
- **Venting Versatility**—The Turbo Ultra High Efficiency can vent vertically or horizontally with 4" or 6" (102mm or 152mm) PVC, CPVC, Polypropylene, Stainless Steel, or ABS vent pipe, and is approved for direct vent closed combustion applications, or those applications that require inside air for combustion. The Turbo Ultra High Efficiency is also approved for unbalanced venting, which means the air intake pipe doesn't have to be vented the same distance as the exhaust. Common vent kits available.



Photo is of UFT120 0400

MICROBAN<sup>®</sup>



### 3 or 5-Year Limited Tank Warranties / 1-Year Limited Warranty on Component Parts.

For more information on warranty, please visit [www.laars.com](http://www.laars.com)

For products installed in USA, Canada, and Puerto Rico. See complete copy of the warranty included with the heater for limitations.

Microban<sup>®</sup> antimicrobial product protection helps prevent the growth of bacteria, mold and mildew that may affect the product. The built-in antimicrobial properties do not protect users or others from disease-causing organisms. Microban<sup>®</sup> is a registered trademark of Microban Products Company.

# Turbo Ultra High Efficiency

## Commercial Gas Water Heater

### Additional Details

- **Ultra Quiet Operation.**
- **Complies with the latest ultra-low NOx requirement (14 ng/J NOx limit for natural gas and 77ppm NOx limit for liquid propane).**
- **ASME Construction Standard on All Models.**
- **Zero Inch Clearance.**
- **Hand Hole Cleanout.**
- **T&P Relief Valve—Installed.**
- **1" (25mm) NPT Side Connection for Space Heating.**
- **Low Restrictive Brass Drain Valve—Durable tamper proof design.**
- **Hot Surface Ignition—For improved operational dependability and durability.**
- **Sanitizing Capability—Temperature setting up to 181°F (83°C).**
- **E.C.O.—A manual reset Energy Cut Off (E.C.O) shuts off all gas in the event of an overheat condition.**
- **Submerged Combustion Chamber—Minimizes radiant heat loss for better efficiency.**

### Optional Equipment Features:

BACnet®/Modbus Gateway Kit: ..... 415-56278-00  
 Optional Condensate Neutralizer Kit: ..... A2123609  
 Common Vent Exhaust Kit - Polypropylene, 2 units:..... 415-56703-01  
 Common Vent Exhaust Kit - Polypropylene, 3 units:..... 415-56703-02

### NATURAL AND LIQUID PROPANE GAS

These water heaters meet or exceed all or portions of (where applicable the minimum efficiency requirements of ASHRAE Standard 90.1 (latest edition).

Model Number	Rated Nominal Volume		Input		Therm. Eff.	Model Number	Rated Nominal Volume		Input		Therm. Eff.
	U.S. Gal.	Imp. Gal.	BTU/Hr. Input		%		Liters	kW/Hr. Input		%	
★ UFT120 0400 A13NCA	125	104	399,999		97.0	★ UFT120 0400 A13NCA	473		117.2		97.0
★ UFT120 0500 A13NCA	125	104	500,000		96.0	★ UFT120 0500 A13NCA	473		146.5		96.0

Model Number	A Floor to Top of Heater in.	B Jacket Dia. in.	C Floor to Hot Water Conn. in.	D Floor to Cold Water Conn. in.	E Floor to Gas Conn. in.	F Floor to Top of Exhaust Conn. in.	G Floor to T&P Conn. in.	H Floor to Air Intake Conn. in.	J Floor to Return Conn. in.	K Depth in.	Water Conn. Dia. in.	Air Intake/Exhaust Conn. Dia. in.	Gas Conn. Dia. in.	Relief Valve Conn. in.	Approx. Shipping Weight lbs.
★ UFT120 0400 A13NCA	78½	32	62¾	117/16	74 1/8	12	61 11/16	74 3/8	36 5/16	37	2	4	1½	1	1,100
★ UFT120 0500 A13NCA	78½	32	62¾	117/16	74 1/8	12	61 11/16	74 3/8	36 5/16	37	2	4	1½	1	1,100

Model Number	A Floor to Top of Heater mm.	B Jacket Dia. mm.	C Floor to Hot Water Conn. mm.	D Floor to Cold Water Conn. mm.	E Floor to Gas Conn. mm.	F Floor to Top of Exhaust Conn. mm.	G Floor to T&P Conn. mm.	H Floor to Air Intake Conn. mm.	J Floor to Return Conn. mm.	K Depth mm.	Water Conn. Dia. mm.	Air Intake/Exhaust Conn. Dia. mm.	Gas Conn. Dia. mm.	Relief Valve Conn. mm.	Approx. Shipping Weight kgs.
★ UFT120 0400 A13NCA	1994	813	1595	291	1890	305	1567	1890	922	940	51	102	38	25	500
★ UFT120 0500 A13NCA	1994	813	1595	291	1890	305	1567	1890	922	940	51	102	38	25	500

For models placed at 2000-7800 ft (610-2377m) altitude, change character 11 to "B"

For propane models, change character 14 to "P"

For models with 5-year warranty, change character 13 to "5"

All models are built with ASME construction

All models comply with the latest ultra-low NOx requirements of 14 ng/J or less for natural gas and 77ppm NOx or less for liquid propane.

14.0" (356mm) w.c. maximum static, 3.5" (89mm) w.c. minimum running (NG) & 8" (203mm) w.c. minimum running (LP).

The water heater must be wired to 120VAC, 60Hz, 15A power supply.

★ = ENERGY STAR® Qualified.



# Turbo Ultra High Efficiency

## Commercial Gas Water Heater

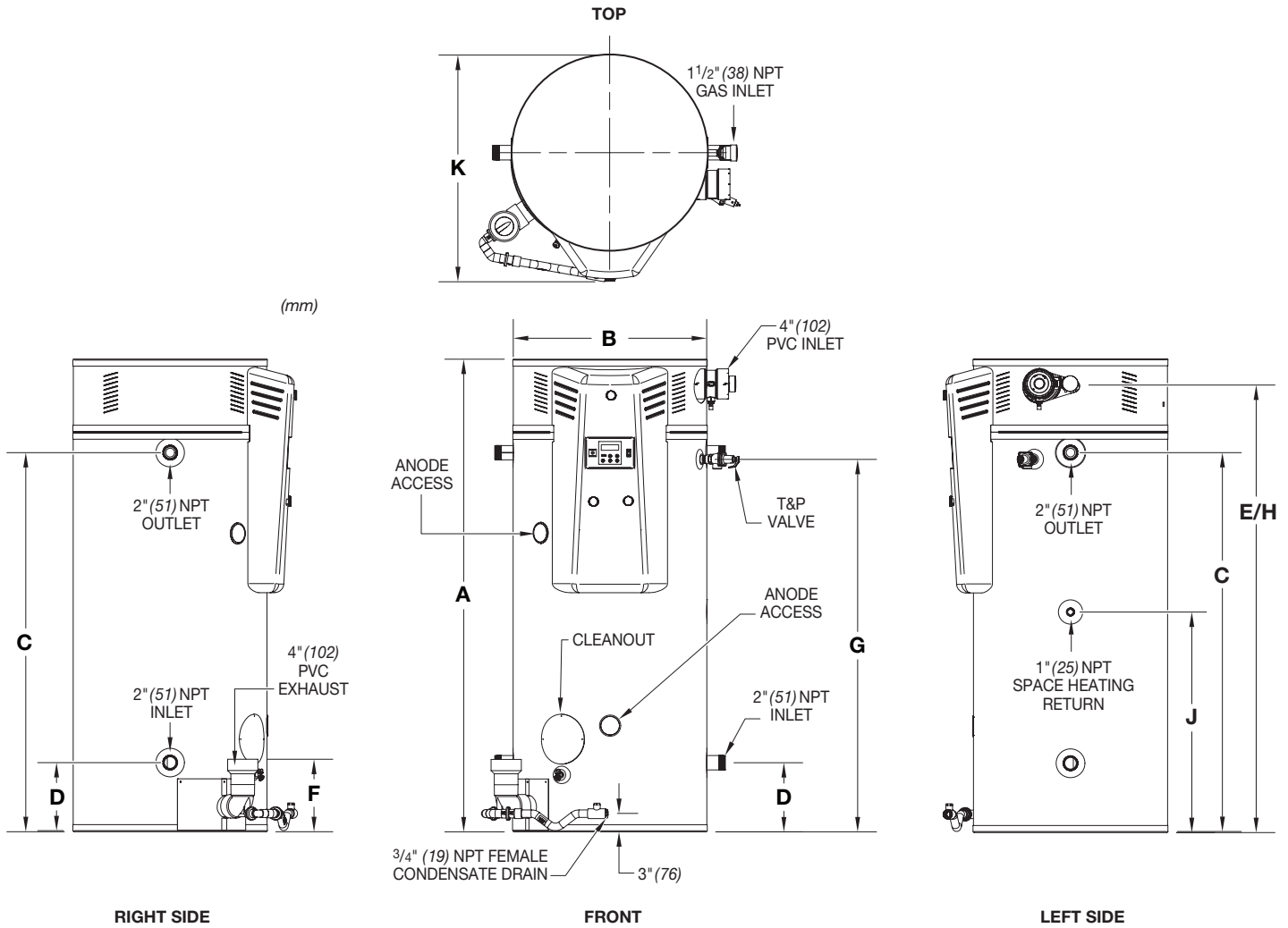

4 in. (102mm.) Vent Pipe	UFT120 0400 399,999 BTU/Hr.		UFT120 0500 500,000 BTU/Hr.	
	Power Vent	Power Direct Vent	Power Vent	Power Direct Vent
Max. Intake Length	N/A	50 ft. (15.24m.)	N/A	50 ft. (15.24m.)
Max. Exhaust Length	100 ft. (30.5m.)	50 ft. (15.24m.)	100 ft. (30.5m.)	50 ft. (15.24m.)

  

6 in. (152mm.) Vent Pipe	UFT120 0400 399,999 BTU/Hr.		UFT120 0500 500,000 BTU/Hr.	
	Power Vent	Power Direct Vent	Power Vent	Power Direct Vent
Max. Intake Length	N/A	120 ft. (36.6m.)	N/A	120 ft. (36.6m.)
Max. Exhaust Length	240 ft. (73.15m.)	120 ft. (36.6m.)	240 ft. (73.15m.)	120 ft. (36.6m.)

Recovery Data																								
Model Number	GPH Recovery at Degree Rise*													LPH Recovery at Degree Rise*										
	30°F	40°F	50°F	60°F	70°F	80°F	90°F	100°F	110°F	120°F	130°F	140°F	17°C	22°C	28°C	33°C	39°C	44°C	50°C	56°C	61°C	67°C	72°C	78°C
UFT120 0400	1568	1176	941	784	672	588	523	470	428	392	362	336	5934	4451	3561	2967	2543	2225	1978	1780	1618	1484	1369	1272
UFT120 0500	1939	1455	1164	970	831	727	646	582	529	485	448	416	7341	5506	4405	3671	3146	2753	2447	2202	2002	1835	1694	1573

\* Based on manufacturer's rated recovery efficiency.

# Turbo Ultra High Efficiency Commercial Gas Water Heater

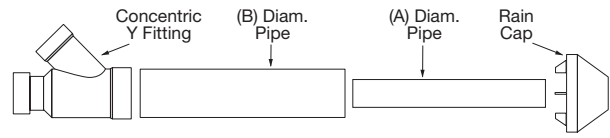
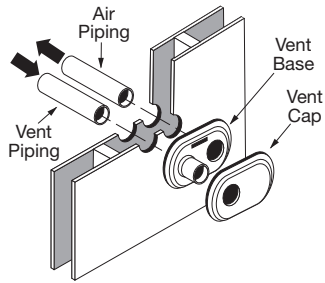

4" Concentric Vent Kits Part Identification		
Concentric Vent Size	(A)	(B)
4 in. (102mm)	4.5 in. (114mm)	6.6 in. (168mm)

Low Profile Termination Kit Model Numbers				
Description	Pipe O.D.	Hole Spacing (ctr to ctr)	IPEX System (1738 or 636)	IPEX Part Number
4" (102mm) Low Profile	4.5" (114mm) Low Profile	5.6" (142mm)	636	196986
4" (102mm) Low Profile	4.5" (114mm) Low Profile	5.6" (142mm)	1738	397086

Appliance Numbers Approved for Concentric Termination Kits				
Model	Description	Part Number	IPEX System (1738 or 636)	IPEX Part Number
UFT120 (0400,0500)	4" (102mm) Concentric Termination	—	636	196021 (PVC), 197021 (CPVC)
UFT120 (0400,0500)	4" (102mm) Concentric Termination	—	1738	397021

## Sample Specification

The water heater shall be a Laars model number UFT-\_\_\_\_\_ with a rated storage capacity of not less than \_\_\_\_\_ gallons/ liters, a minimum gas input of \_\_\_\_\_ BTU/Hr., a minimum recovery of \_\_\_\_\_ GPH/LPH at 100°F (56°C) temperature rise, and a Thermal Efficiency Rating of \_\_\_\_%. It shall be design certified by UL for 181°F (83°C) application, either with or without a separate storage tank. The tank shall be lined with Vitraglas® vitreous enamel with Microban® antimicrobial technology and shall have a bolted hand hole cleanout. The tank shall have two powered anode rods. The heater shall be insulated with Non-CFC foam. This water heater shall be equipped with an electronic ignition system and an ASME rated T&P relief valve. This water heater shall have a premix closed combustion system for venting 4" (102mm), or 6" (152mm) PVC, CPVC, Polypropylene, Stainless Steel, or ABS vent pipe. Common venting options with approved kits. This water heater shall be equipped with BMS integration capabilities with appropriate kit. The water heater shall be factory assembled and tested. The water heater shall be approved for zero inch clearance to combustibles. A digital LCD display shall be integrated into the front and be an adjustable electronic thermostat to any temperature up to 181°F. A recycling Energy Cut Off (E.C.O.) shuts off all gas in the event of an overheat condition. The entire installation shall be made in compliance with state and local codes and ordinances.

## GENERAL:

All gas water heaters are certified at 300 PSI test pressure (2068 kPa) and 150 PSI working pressure (1034 kPa). All models design-certified by UL to ANSI standard Z21.10.3, for up to 181°F (83°C) application as an Automatic Storage Heater. As an Automatic Storage Heater, all models are complete, self-contained water heating systems. It needs no separate storage tank, pump, wiring or elaborate piping network. When equipped with a mixing valve, all models can be stored at a sanitizing temperature of 181°F (83°C) and supply lower temperature general purpose hot water simultaneously.

*Dimensions and specifications subject to change without notice in accordance with our policy of continuous product improvement.*



**Customer Service and Product Support: 800.900.9276 • Fax 800.559.1583**  
**Headquarters: 20 Industrial Way, Rochester, NH, USA 03867 • 603.335.6300 • Fax 603.335.3355**  
**9 Brigden Gate, Halton Hills, Ontario, Canada L7G 0A3 • 905.203.0600 • Fax 905.636.0666 • www.Laars.com**  
 ©Laars Heating Systems • ©2026, Bradford White Corporation, USA. All rights reserved.