



# HIGH EFFICIENCY COMMERCIAL GAS WATER HEATER INSTALLATION & OPERATION MANUAL WITH TROUBLESHOOTING GUIDE

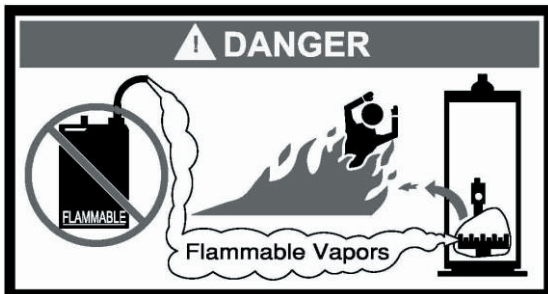
## LUHE120T Model



### **WARNING**

If the information in these instructions are not followed exactly, a fire or explosion may result causing property damage, personal injury, or death.

- Do NOT store or use gasoline or other flammable vapors and liquids in the vicinity of this or any other appliance.
- **WHAT TO DO IF YOU SMELL GAS**
  - Do NOT try to light any appliance.
  - Do NOT touch any electrical switch; Do NOT use any phone in your building.
  - Immediately call your gas supplier from a neighbor's phone. Follow the gas supplier's instructions.
  - If you cannot reach your gas supplier, call the fire department.
- For customer comfort, safety, and convenience, it is recommended this water heater be installed and serviced by a plumbing professional.



As required by the state of California Proposition 65.

**SAVE THESE INSTRUCTIONS AND KEEP FOR FUTURE REFERENCE**

# SECTION I: IMPORTANT INFORMATION

## READ CAREFULLY

This gas-fired water heater is design certified by CSA International under the American National Standard, Z21.10.3 (as indicated on the rating plate) and CAN/CGA 4.3-M (as indicated on the rating plate) available from CSA Standards Association, 5060 Spectrum Way, Mississauga, Ontario, CANADA L4W 5N6.

This water heater must be installed in accordance with local codes. In the absence of local codes, it must be installed in compliance with the National Fuel Gas Code (ANSI Z223.1-Latest Edition), or in Canada CAN/CGA B149.1 Natural Gas Installation Code (Latest Edition) or CAN/CGA B149.2 Propane Installation Code (Latest Edition).

The following terms are used throughout this manual to bring attention to the presence of hazards at various risk levels, or to important information concerning product life.

### **DANGER**

Indicates an imminently hazardous situation, which, if not avoided, will result in death, serious injury or substantial property damage.

### **CAUTION**

Indicates potentially hazardous situation, which, if not avoided, may result in moderate or minor injury or property damage.

### **WARNING**

Indicates a potentially hazardous situation, which, if not avoided, could result in death, serious injury or substantial property damage.

### **NOTICE**

Indicates special instructions on installation, operation or maintenance, which are important but not related to personal injury hazards.

## NOTICE

This water heater has a limited warranty. The warranty for this water heater is valid only if the water heater has been installed, maintained, and operated in accordance with these instructions.

## TABLE OF CONTENTS

<b>SECTION I: IMPORTANT INFORMATION</b> .....	<b>2</b>	<b>SECTION VII: GAS CONNECTIONS</b> .....	<b>38</b>
<b>SECTION II: SPECIFICATIONS</b> .....	<b>5</b>	<b>SECTION VIII: ELECTRICAL CONNECTIONS</b> .....	<b>40</b>
<b>SECTION III: GENERAL INFORMATION</b> .....	<b>6</b>	<b>SECTION IX: OPERATING INSTRUCTIONS</b> .....	<b>43</b>
<b>SECTION IV: INSTALLATION INSTRUCTIONS</b> .....	<b>9</b>	<b>SECTION X: MAINTENANCE</b> .....	<b>50</b>
<b>SECTION V: WATER CONNECTIONS</b> .....	<b>15</b>	<b>SECTION XI: DIAGNOSTIC AND</b>	
<b>SECTION VI: VENTING</b> .....	<b>17</b>	<b>TROUBLESHOOTING GUIDE</b> .....	<b>55</b>

## DANGER

**DO NOT** store or use gasoline or other flammable, combustible, or corrosive vapors and/or liquids in the vicinity of this or any other appliance.

**DO NOT** install any damaged venting system components. If damage is evident then please contact the supplier where the water heater was purchased, or the manufacturer listed on the rating plate for replacement parts.

Use only vent terminals provided or factory authorized terminals for venting this water heater.

This water heater is equipped with an adjustable thermostat to control water temperature. Hot water temperatures required for automatic dishwasher and laundry use can cause scald burns resulting in serious personal injury and/or death. The temperature at which injury occurs varies with the person's age and the time of exposure. The slower response time of disabled persons and elderly increases the hazards to them. **NEVER** allow small children to use a hot water tap, or to draw their own bath water. **NEVER** leave a child or disabled person unattended in a bathtub or shower.

Failure to properly install the vent and air intake (if applicable) system could result in property damage, personal injury, or death.

## WARNING

Improper installation, adjustments, alteration, service, or maintenance can cause property damage, personal injury, or loss of life. Failure to follow all instructions in the proper order can cause personal injury or death. Read and understand all instructions, including all those provided with the appliance before installing, starting-up, operating, servicing, or maintaining this appliance. Keep this manual and literature in legible condition with this water heater for reference by owner and service technician.

This water heater requires regular maintenance and service to operate safely. Follow the instructions contained in this manual.

Installation, maintenance, and service must be performed only by a qualified, skilled, and knowledgeable installer or service provider.

Installation is **NOT** complete unless a temperature and pressure relief valve is installed into the proper location at the top of this water heater.

It is the responsibility of the installing contractor to see that all controls are correctly installed and are properly operating when the installation is complete.

This water heater is suitable for installation on combustible flooring. **DO NOT** install water heater directly on carpeting.

**DO NOT** operate this water heater without first being certain it is filled with water.

**DO NOT** tamper with or alter the water heater and/or controls.

**DO NOT** operate water heater with jumpered or absent controls or safety devices.

**DO NOT** operate water heater if any external part has been under water. Immediately call a qualified service agency to inspect the appliance and to replace any part of the control system, including gas controls, that has been under water.

**DO NOT** attempt to use this water heater with any gas other than the type listed on the rating plate. **DO NOT** attempt to convert this water heater for use with a gas other than the type for which it is equipped. Failure to use the proper gas can create an unsafe condition resulting in property damage, personal injury, or death. Consult your local gas supplier or gas company if there are any questions.

**DO NOT** operate this water heater if the input rate exceeds the rate shown on the water heater rating plate.

This water heater contains very hot water under high pressure. **DO NOT** unscrew any pipe fittings or attempt to disconnect any components of this water heater without assuring the water is cool and is **NOT** under pressure. Always wear protective clothing and equipment when installing, starting up, or servicing this water heater to prevent scald injuries. **DO NOT** rely on the temperature gauges to determine the temperature. **DO NOT** touch any components unless they are cool.

This water heater **must** be properly vented and connected to an approved vent system in good condition. **DO NOT** operate water heater with the absence of an approved vent system. A clean and unobstructed vent system is necessary, to allow noxious fumes that could cause injury or loss of life, to vent safely and will contribute toward maintaining the water heater's efficiency.

**DO NOT** use this appliance if any external part to the tank has been submerged in water. You should contact a qualified service technician to inspect the appliance and to replace any part of the control system including the combination gas control which has been submerged in water. See the Gas Connections section of this manual before servicing or replacing a water heater that has had any external part to the tank submerged in water.

## **WARNING**

This water heater needs fresh air for safe operation and must be installed so there are provisions for adequate combustion and ventilation air. Insufficient air supply will cause a recirculation of combustion products resulting in contamination that may be hazardous to life. This will result in carboning or sooting of the combustion chamber, burners, and flue tubes and creates a risk of asphyxiation.

This water heater requires its own separate venting system. **DO NOT** connect the exhaust vent into an existing vent pipe or chimney.

Flammable items, pressurized containers, or any other potential fire hazardous articles must **NEVER** be placed on or adjacent to the water heater. Open containers of flammable material should **NOT** be stored or used in the same room with this water heater.

Insulation blankets are not required for this water heater. This water heater meets or exceeds the ASHRAE/IES 90.1b (latest edition) standards with respect to insulation and standby loss requirements.

Hydrogen gas can be produced in an operating water heater that has not had water drawn from the tank for a long period of time (generally two weeks or more). **HYDROGEN GAS IS EXTREMELY FLAMMABLE.** To prevent the possibility of injury under these conditions, we recommend a hot water faucet to be open for several minutes before you use any electrical appliance which is connected to the hot water system. If hydrogen is present, there will be unusual sounds such as air escaping through the pipes as hot water begins to flow. **DO NOT** smoke or have open flame near the faucet at the time it is open.

## **WARNING**

Prior to connecting the gas supply line to a gas fired water heater, ensure that the gas supply line does **NOT** have moisture/water or dirt/scale inside the gas line. Commonly this check is done at the lowest point in the gas distribution system prior to gas burning appliances.

## **WARNING**

Liquefied petroleum gases/propane gas is heavier than air and will remain at floor level if there is a leak. Basements, crawl spaces, closets and areas below ground level will serve as pockets for accumulation of leaking gas. Before lighting, smell all around the appliance area for gas. Be sure to smell next to the floor.

### **IF YOU SMELL GAS:**

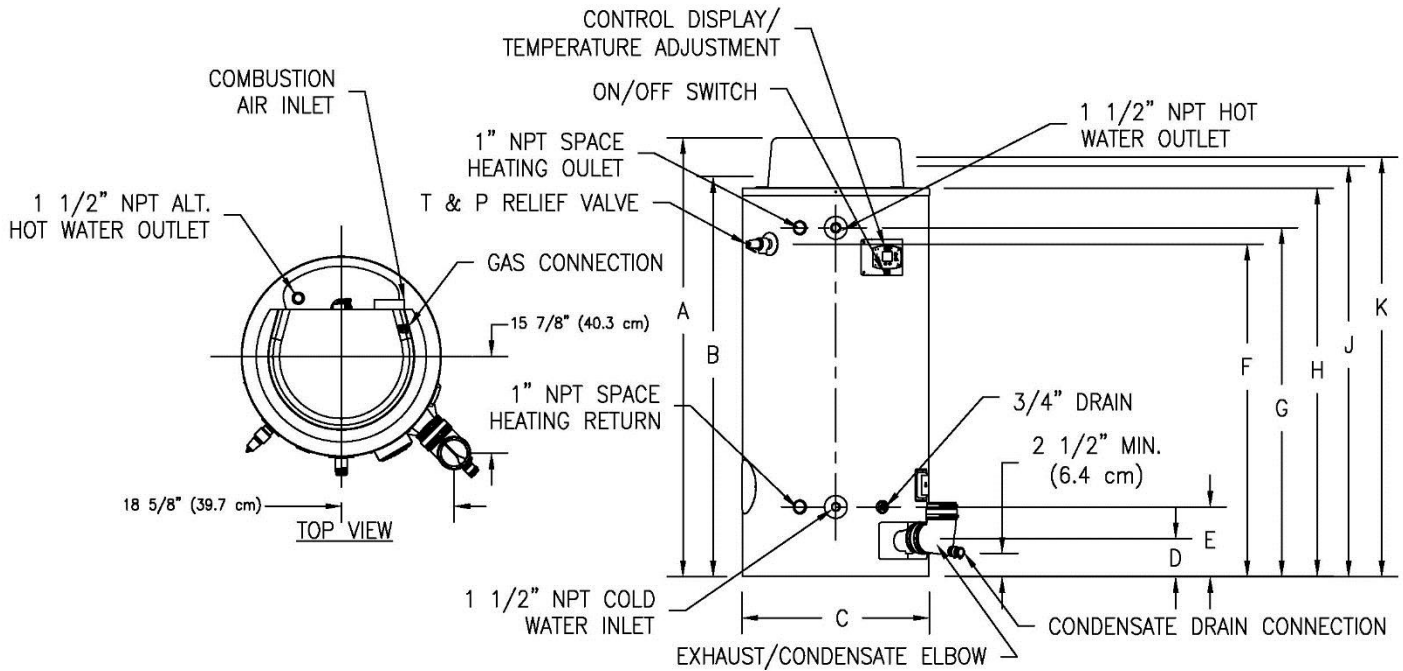
- **DO NOT** try to light any appliance.
- **DO NOT** touch any electric switch; **DO NOT** use any telephone in your building.
- Immediately call your gas supplier from a telephone in another building. Follow the gas supplier's instructions.
- If you cannot reach your gas supplier, call the fire department.

**DO NOT OPERATE THE APPLIANCE UNTIL THE LEAKAGE IS CORRECTED!**

### **NSF Compliance**

To comply with NSF (National Sanitation Foundation) requirements, this water heater must be sealed to the floor with sealant, in a smooth and easily cleanable way.

## SECTION II: SPECIFICATIONS



**Figure 1 – Dimensional Layout**

**Table 1 – Specifications**

			DIMENSIONS (INCHES)							
Model No.	Input Rate BTU/h	Storage Capacity U.S. Gallons	A Height	B Floor to Alt. Hot Water Outlet	C Dia.	D Floor to Vent Outlet	E Floor to Inlet Water Conn.	F Floor to T&P Valve Conn.	G Floor to Hot Outlet Water Conn.	H Floor to Top of Heater
120T400	399,999	119	77 1/8	70 3/8	33	6 3/4	12 1/4	58 1/2	61 1/4	68 1/4
120T500	499,999	119	77 1/8	70 3/8	33	6 3/4	12 1/4	58 1/2	61 1/4	68 1/4
Model No.	Input Rate BTU/h	Storage Capacity U.S. Gallons	J Floor to Air Intake	K Floor to Gas Conn.	Front Water Conn. Dia.	Space Heating Conn. Dia.	Gas Conn. Dia.	Relief Valve Open	Shipping Wt. (LBS)	
120T400	399,999	119	71	73 3/4	1 1/2	1	1	1	1120	
120T500	499,999	119	71	74 7/8	1 1/2	1	1	1	1135	
			DIMENSIONS (MILLIMETERS)							
Model No.	Input Rate KW	Storage Capacity Liter	A Height	B Floor to Alt. Hot Water Outlet	C Dia.	D Floor to Vent Outlet	E Floor to Inlet Water Conn.	F Floor to T&P Valve Conn.	G Floor to Hot Outlet Water Conn.	H Floor to Top of Heater
120T400	117.22	450	1959	1787	838	171	311	1486	1556	1733
120T500	146.54	450	1959	1787	838	171	311	1486	1556	1733
Model No.	Input Rate KW	Storage Capacity Liter	J Floor to Air Intake	K Floor to Gas Conn.	Front Water Conn. Dia.	Space Heating Conn. Dia.	Gas Conn. Dia.	Relief Valve Open	Shipping Wt. (kgs)	
120T400	117.22	450	1803	1873	38	25	25	25	508	
120T500	146.54	450	1803	1902	38	25	25	25	515	

---

## SECTION III: GENERAL INFORMATION

---

This water heater contains the following features:

### Main Power On/Off Switch

The front panel of this water heater has an ON/OFF switch, which has markings to indicate whether the main power to the water heater is turned on or off.

### Combustion System

This water heater is equipped with a self-compensating negative pressure pre-mix combustion system. As the blower operates, air is drawn in through the air intake and into a venturi, which pulls gas from the gas valve. The gas and air are then mixed in the combustion blower and sent through the transition tube into the burner. The Direct Spark Ignition (DSI) System then ignites the gas/air fuel mixture to produce flue products (combustion). The flame sensor signals the ignition control board (described below) that a flame is present.

### Integrated Control

The Integrated Control System consists of a control board and a digital water heater display. The digital water heater display is on the top front of the water heater for setting and displaying the temperature setpoint and monitoring the status of the water heater. Pressing the temperature UP and DOWN buttons changes the temperature setpoint. The temperature format may be displayed in degrees F or degrees C. The water heater display will show diagnostic codes in the event the water heater needs servicing. The temperature readings of the tank sensor can be monitored in Service Mode. The display can show up to 10 previous error codes in Service Mode to further aid in servicing the water heater.

The single control board has plug in wiring harnesses to reduce the chance of mis-wiring. The control board controls the combustion blower, ignition timings, and gas valve to run the combustion system in order to maintain the desired tank temperature. The sequence of operations is described in detail in the Diagnostic Section (page 55).

### Adjustable Thermostat

This water heater is equipped with an adjustable thermostat as part of the Integrated Control System to control water temperature. Hot water temperatures required for automatic dishwasher and laundry use can cause scald burns resulting in serious personal injury and/or death.

The temperature may be adjusted from about 100°F (38°C) to about 180°F (82°C). The thermostat was adjusted to 100°F (38°C) before the water heater was shipped from the factory. It is recommended that lower temperatures be used to avoid the risk of scalding. Refer to the scald warnings and the section on scalding in Section V: Water Connections (page 15). It is further recommended, in all cases, that the water temperature be set for the lowest temperature that satisfies your hot water requirements for the installation. This will also provide the most energy efficient operation of the water heater and minimizes scale formation.

Setting the water heater temperature at 120°F (49°C) will reduce the risk of scalds. Some states require setting lower temperatures for specific installations.

The top immersion well of the single sensor control contains a redundant sensor for the high limit (energy cutoff). The high limit circuit interrupts the main burner gas flow, should the water temperature exceed approximately 207°F (97.2°C). Error code "80" will be shown on the water heater control display if the high limit temperature has been exceeded. Should the high limit switch activate, it must be manually reset. This should **only** be done by a qualified service technician after the cause of overheating has been corrected.

Contact your qualified installing contractor, service provider, or the manufacturer listed on the rating plate if continued high limit operation occurs.

### Service Panels

The service panels are located behind the service panel access covers, which are located around the exhaust elbow side of the water heater. These panels contain a pressure switch that monitors the pressure in the exhaust pipe in case the vent system becomes blocked. An exhaust high limit switch is used to monitor the ambient temperature of the exhaust collector. This is a manually resettable switch. If this switch continues to trip, please contact an authorized service agency.

### Latches

The latches allow easy access for servicing the water heater from the top. Open the three latches and lift the surround up for servicing. No tools are required to obtain access to the top of the water heater. Replace the surround and re-latch when the service has been completed.

## Temperature and Pressure Relief Valve

### **WARNING**

Keep clear of the combination temperature and pressure relief valve discharge line outlet. The discharge may be hot enough to cause scald injury. The water is under pressure and may splash.

For protection against excessive temperatures and pressure, install temperature and pressure protective equipment required by local codes; **not** less than a combination temperature and pressure relief valve certified by a nationally recognized testing laboratory that maintains periodic inspection of production of listed equipment or materials as meeting the requirements of the Standard for *Relief Valves and Automatic Gas Shutoff Devices for Hot Water Supply Systems*, ANSI Z21.22 and the Standard *CAN1-4.4 Temperature, Pressure, Temperature and Pressure Relief Valves and Vacuum Relief Valves*. The combination temperature and pressure relief valve must be marked with a maximum set pressure that does **NOT** exceed the maximum working pressure of the water heater. The combination temperature and pressure relief valve rating must **NOT** be less than the hourly rating of the water heater.

Install the combination temperature and pressure relief valve into the opening provided and marked for this purpose on the water heater.

**Note:** Some models may already be equipped or supplied with an installed combination temperature and pressure relief valve. Verify that the combination temperature and pressure relief valve is in compliance with local codes. If the combination temperature and pressure relief valve does not comply with local codes, replace it with one that does. Follow the installation instructions on page 11.

Install a discharge line so that water discharged from the combination temperature and pressure relief valve will exit within 6 in (15.2 cm) above, or any distance below the structural floor and **cannot** contact any live electrical part. The discharge line is to be installed to allow for complete drainage of both the combination temperature and pressure relief valve and the discharge line where it will **NOT** damage property. The discharge opening must **NOT** be subjected to blockage or freezing. **DO NOT** thread, plug or cap the discharge line. It is recommended that a minimum clearance of 4 in (10.2 cm) be provided on the side of the water heater for servicing and maintenance of the combination temperature and pressure relief valve.

**DO NOT place a valve between the combination temperature and pressure relief valve and the tank.**

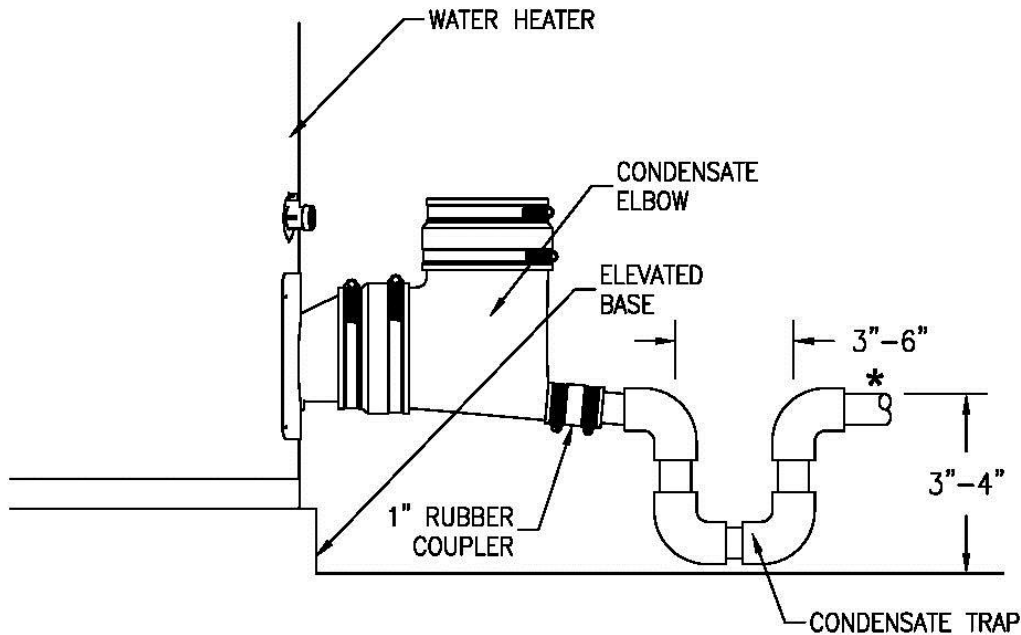
## Condensate Drain

The water heater should either be raised several inches above the floor on a concrete slab or use a low-profile condensate pump to allow free drainage of condensate from the elbow drain fitting. This water heater is a condensing type unit and requires a drain to be located in close proximity to allow the condensate to drain safely. The condensate drains from the unit at the field installed exhaust condensate elbow located near the bottom of the unit. Using 1" PVC create a drain trap, as shown in Figure 2, which connects to the condensate elbow using the supplied rubber coupler.

Also use 1" PVC from the drain trap to the drain. Make sure the condensate drains line slopes down, away from the water heater at least 1/8 in per foot toward the drain. The condensate drain pipe must **NOT** be routed through an area subject to below freezing temperatures. The condensate build-up will block the exhaust outlet, which will cause improper operation. Refer to Figure 2 for the proper connection of an elbow to the drain outlet and a condensate trap.

### **CAUTION**

Failure to properly install the condensate drain as directed above, as well as shown in Figure 2, may result in damage and/or cause improper operation of the water heater. Any damage resulting from failure to install the condensate drain as directed will **NOT** be covered by the warranty.



**Figure 2 – Condensate Elbow with Trap**

\*Outlet of condensate trap must not be higher than outlet of condensate elbow

### Condensate Neutralization

The condensate draining from the water heaters covered in this manual have PH levels between 4.3 and 5.0. Install a commercially available neutralizing kit if required by local code.

**NOTE:** Lower PH levels are acidic. Do **NOT** connect a metal drain line, such as copper, to the water heater for this reason.

### Cleanout

These models are equipped with a cleanout opening to aid in removal of hard water deposits from the tank bottom. If this water heater operates under hard water conditions, the following should be performed at least every 3 months: Turn OFF the water supply and drain the water heater. Remove the cleanout jacket cover and tank cover. When cleaning the tank, care must be taken to avoid trying to break deposits loose as this could damage the glass lining and shorten the life of the water heater. After cleaning, inspect gasket and reuse or replace, re-install the cleanout tank cover and jacket cover, and refill with water. Refer to Section X: Maintenance (page 50) for the procedures for filling and draining the water heater.

### Powered Anode System

The powered anode system provides corrosion protection to the tank by supplying a low voltage current to the titanium anode rods and then periodically comparing this current with the potential between the anode rod and tank wall to make corrections. The powered anode system is designed to extend the tank life without requiring anode rod replacement. The powered anode system consists of titanium powered anode rods and a powered anode control module located on the control panel. More details on the powered anode system are in Section X: Maintenance (page 50).

### Dishwashing Machine Requirements

All dishwashing machines meeting the National Sanitation Foundation requirements are designed to operate with water flow pressures between 15 and 25 lbs/in<sup>2</sup>. Flow pressures above 25 lbs/in<sup>2</sup>, or below 15 lbs/in<sup>2</sup>, will result in improperly sanitized dishes.

The National Sanitation Foundation also recommends circulation of 180°F (82°C) water. Where this is done, the circulation should be very gentle so that it does not cause any unnecessary turbulence inside the water heater. The circulation should be just enough to provide 180°F (82°C) water at the point of take-off to the dishwashing machine. Adjust flow by means of the valve in the circulation line.



## SECTION IV: INSTALLATION INSTRUCTIONS

### **WARNING**

**INSTALLATION OF THIS WATER HEATER REQUIRES ABILITY EQUIVALENT TO THAT OF A LICENSED TRADESMAN IN THE FIELD INVOLVED. PLUMBING, AIR SUPPLY, VENTING, GAS SUPPLY AND ELECTRICAL WORK ARE REQUIRED.**

**DO NOT ATTEMPT TO LIGHT ANY GAS APPLIANCE IF YOU ARE NOT CERTAIN OF THE FOLLOWING:**

- Liquefied petroleum gases/propane gas and natural gas have an odorant added by the gas supplier that aids in detection of the gas.
  - Most people recognize this odor as a “sulfur” or “rotten egg” smell.
  - Other conditions, such as “odorant fade” can cause the odorant to diminish in intensity, or “fade,” and not be as readily detectable.
  - If you have a diminished sense of smell or are in any way unsure of the presence of gas, immediately contact your gas supplier from a telephone in another building.
  - Gas detectors are available. Contact your gas supplier or plumbing professional for more information.
- Liquefied petroleum gases/propane gas is heavier than air and will remain at floor level if there is a leak. Basements, crawl spaces, closets, and areas below ground level will serve as pockets for accumulation of leaking gas. Before lighting, smell all around the appliance area for gas. Be sure to smell next to the floor.

**IF YOU SMELL GAS:**

- **DO NOT** try to light any appliance.
- **DO NOT** touch any electric switch; **DO NOT** use any telephone in your building.
- Immediately call your gas supplier from a telephone in another building. Follow the gas supplier’s instructions.
- If you cannot reach your gas supplier, call the fire department.

**DO NOT OPERATE THE APPLIANCE UNTIL THE LEAKAGE IS CORRECTED!**

### **WARNING**

This water heater **must** be located in an area where leakage of the tank, water line connections, or the combination temperature and pressure relief valve will **not** result in damage to the area adjacent to the water heater or to lower floors of the structure. When such locations cannot be avoided, a suitable drain pan must be installed under the water heater. The drain pan depth must be suitable for draining and collecting water and have a minimum diameter of at least 4 in (10.2 cm) or greater measured from the jacket of the water heater. The drain pan, as described above, can be purchased from your plumbing professional. The drain pan must be piped to an adequate drain. The piping must be at least 3/4 in (2 cm) in diameter and pitched for proper drainage.

Anode rods have been installed in the tank head of the water heater to extend tank life. The removal of these anodes, except for inspection and/or replacement, will nullify the warranty. In areas where water is unusually active, an odor may occur at the hot water faucet due to a reaction between the anode and the impurities in the water. If this should happen, alternative anodes may be purchased from the supplier that installed this water heater. This will minimize the odor while protecting the tank. Additionally, the water heater should be flushed with appropriate dissolvers to eliminate any bacteria.

**Note: For California installation this water heater must be braced, anchored, or strapped to avoid falling or moving during an earthquake. See instructions for correct installation procedures. Instructions may be obtained from the DSA Headquarters Office: 1102 Q Street, Suite 5100, Sacramento CA 95811.**

**THIS WATER HEATER *MUST* BE INSTALLED INDOORS OUT OF THE WIND AND WEATHER. THIS WATER HEATER *MUST NOT* BE INSTALLED IN ANY LOCATION WHERE GASOLINE OR FLAMMABLE VAPORS ARE LIKELY TO BE PRESENT, UNLESS THE INSTALLATION IS SUCH TO ELIMINATE THE PROBABLE IGNITION OF GASOLINE OR FLAMMABLE VAPORS.**

## Unpacking/Inspection

1. Inspect carefully for any signs of damage.
2. Any claims for damage or shortage in shipment must be filed immediately with the shipper and noted on the Bill of Lading.

## NOTICE

The vent terminal that is supplied with this water heater are stored at the top in the Combustion Assembly Compartment. The condensate elbow and rubber couplers are secured to the bottom of the crating.

## Locating the Water Heater

1. Locate the water heater in front of final position before removing the crate.
2. Locate so that venting connections will be short and direct.
3. This water heater is suitable for installation on combustible floor. Do **NOT** install this water heater directly on carpeting. If the water heater is to be installed on carpeting, it must be installed on top of a metal or wood panel extending beyond the full width and depth of the appliance by at least three 3 in (7.6 cm) in any direction or, if the appliance is to be installed in an alcove or closet, the entire floor must be covered by the panel.
4. For basement installation, provide a solid, level, and elevated base such as concrete or other suitable pad to raise the water heater at least 3 in (7.6 cm) to provide a slope of 1/4 in/ft (.635 cm/m) for the condensate line to a suitable drain.
5. Minimum clearance to combustible material is 0 in (0 cm) for the Top, Sides, and Rear of this water heater. However, it is recommended that **at least 18 in (45.7 cm) from the Top, 24 in (61 cm) from the Front, 4 in (10.2 cm) for the Left Side and Rear, and 12 in (30.5 cm) from the Right Side Exhaust Elbow of the water heater be provided for servicing.** Clearance for servicing may be reduced down to minimum clearance to combustible material, but service time and effort may be greatly increased.

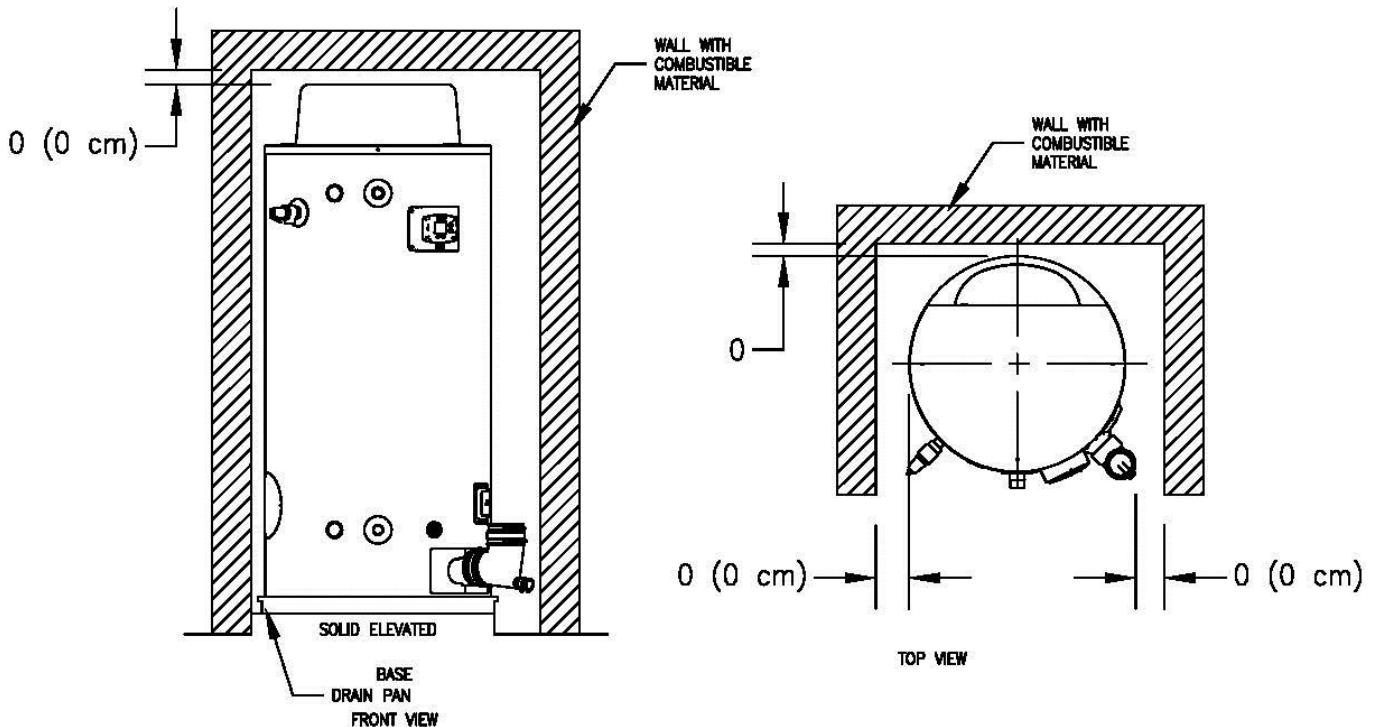
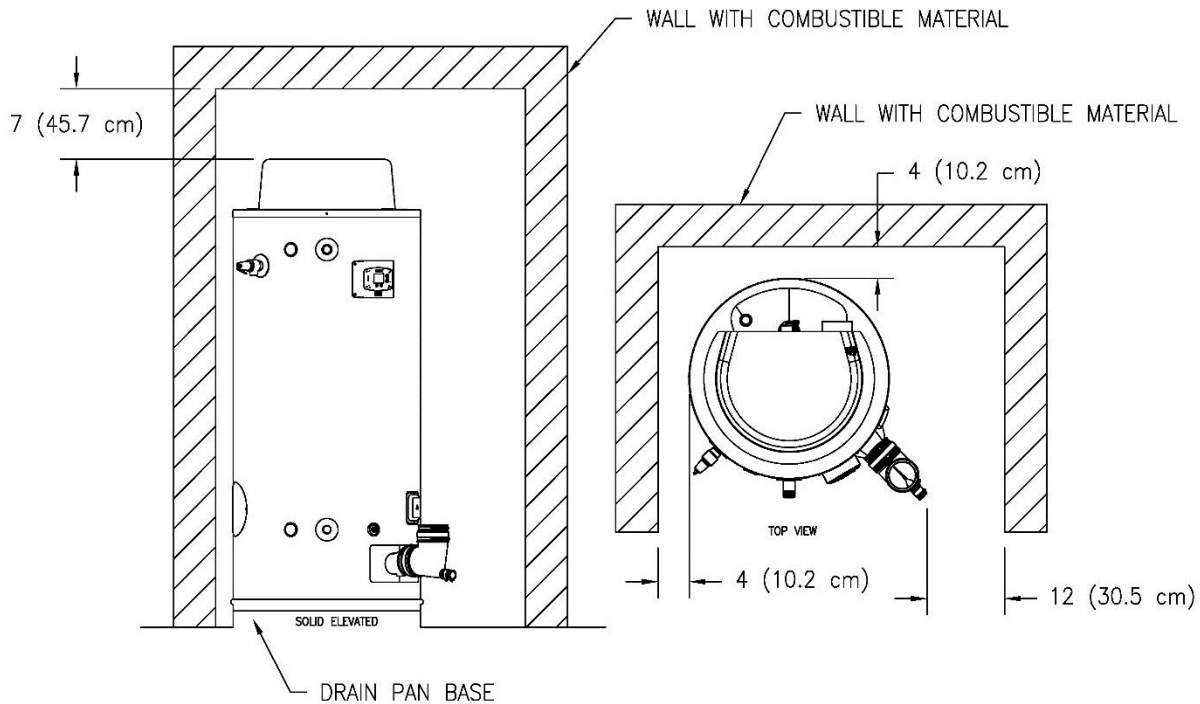


Figure 3a – Minimum Clearance to Combustible Material



**Figure 3b – Recommended Minimum Clearances for Service Access**

### Removing the Crate

1. Remove all banding and pry off crate sides carefully so as to not damage the water heater.
2. Carefully roll/lift the water heater from the crate base.

### ⚠ CAUTION

**DO NOT** drop water heater. **DO NOT** bump water heater jacket against floor.

**DO NOT** bump exhaust vent pipe against crate or other objects. This will damage the heater and cause it to be inoperable or create nuisance problems.

### Moving the Water Heater to a Permanent Position

1. Move the water heater to permanent position by sliding or walking.
2. Place drain pan underneath the water heater.

### Installing Temperature and Pressure Relief Valve (if not already installed)

### ⚠ DANGER

Temperature setting should **NOT** exceed a safe temperature at fixtures. See water temperature control warning in Section V: Water Connections. If higher preheat temperatures are necessary to obtain adequate booster output, add an ASSE approved mixing device for hot water supplied to fixtures.

### ⚠ WARNING

Temperature and pressure relief valve discharge piping **must** be piped near floor to eliminate potential of severe burns. **DO NOT** pipe in any area where freezing could occur. **DO NOT** install any shut-off valves, plugs, or caps to the temperature and pressure relief valve or piping.

### ⚠ CAUTION

If the building cold water supply has a back-flow preventer, check valve, or water meter with check valve, provisions for thermal expansion of water in the hot water system **must** be provided.

## Location

### **WARNING**

**KEEP APPLIANCE AREA CLEAR AND FREE OF COMBUSTIBLE MATERIALS, GASOLINE, AND OTHER FLAMMABLE VAPORS AND LIQUIDS.**

This water heater **must** be located in an area where the general public does **NOT** have access to set temperatures.

### **Air Requirements**

1. Do **NOT** obstruct the flow of combustion and ventilating air.
2. For safe operation, adequate air is needed for combustion and ventilation. Sooting may result in serious damage to the water heater and risk of fire or explosion. It can also create a risk of asphyxiation. Such a condition often will result in a yellow, luminous burner flame, causing carboning or sooting of the combustion chamber, burner, and flue tubes.

### **Mechanical Exhausting of Room Air**

Where an exhaust fan is installed in the same room with this water heater and combustion air is drawn from inside the room, sufficient openings for air **must** be provided in the walls.

### **CAUTION**

Undersized openings will cause air to be drawn into the room through the water heater's venting system, causing poor combustion that may be hazardous to life. **Sooting may result in serious damage to the water heater and risk of fire or explosion, which can also create a risk of asphyxiation.** Refer to local codes and /or National Fuel Gas Code for proper air opening sizing.

### **Unconfined Space**

1. In buildings of conventional frame, brick, or stone construction, unconfined spaces may provide adequate air for combustion and ventilation.
2. If the unconfined space is within a building of tight construction (buildings using the following construction: weather stripping, heavy insulation, caulking, vapor barrier, etc.), air for combustion and ventilation **must** be obtained from outdoors. This may be accomplished by piping air directly to the water heater from outside or providing opening or ducts in the wall. The installation instructions for confined spaces in tightly constructed buildings **must** be followed to ensure adequate air supply.

### **Confined Space (Spaces having less than 50 ft<sup>3</sup>/1000 BTU/hr (4.8 m<sup>3</sup>/kW))**

1. When drawing combustion air from inside a conventionally constructed building to a confined space, such a space shall be provided with two permanent openings.
  - The top opening is to be located within 12 in (30 cm) of the enclosure top and the bottom opening within 12 in (30 cm) of the enclosure bottom.
  - Each opening shall have a free area of at least 1 square inch per 1000 BTU per hour (2200 mm<sup>2</sup>/kW) of the total input of all appliances in the enclosure, but not less than 100 in<sup>2</sup>.
2. If the confined space is within a building of tight construction, air for combustion and ventilation must be obtained from outdoors. This may be accomplished by piping air directly to the water heater from outside or providing opening or ducts in the wall. When directly communicating with the outdoors through vertical ducts, two permanent openings, located in the above manner, shall be provided.
  - Each opening shall have a free area of not less than 1 square inch per 4000 BTU per hour (550 mm<sup>2</sup>/kW) of the total input of all appliances in the enclosure.
  - If horizontal ducts are used, each opening shall have a free area of not less than 1 square inch per 2000 BTU hour (1100 mm<sup>2</sup>/kW) of the total input of all appliances in the enclosure.
3. If the water heater is installed as a direct vent (outside air piped directly to the water heater), then additional openings, other than the opening for the air intake, are not required. However, adequate ventilation air must be provided in all cases to prevent increased room temperature.

### **Chemical Vapor Corrosion**

Corrosion of the flue ways and vent system will occur if air for combustion contains certain chemical vapors. Such corrosion may result in poor combustion and create a risk of asphyxiation, as well as reducing the life of the water heater. Spray can propellants, cleaning solvents, refrigerator and air conditioning refrigerants, swimming pool chemicals, calcium and sodium chloride, waxes and process chemicals are corrosive. Products of this sort should **NOT** be stored near the water heater or outside by the air intake (if applicable).

## Typical Installation Illustrations

### CAUTION

If the building cold water supply has a back-flow preventer, check valve, or water meter with check valve provisions for thermal expansion of water in the hot water system **must** be provided.

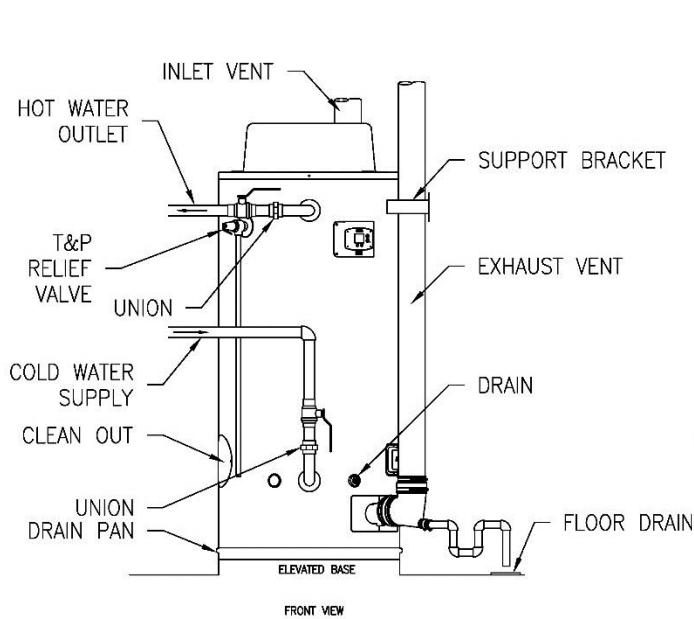


Figure 4 – Typical Front Inlet Connection

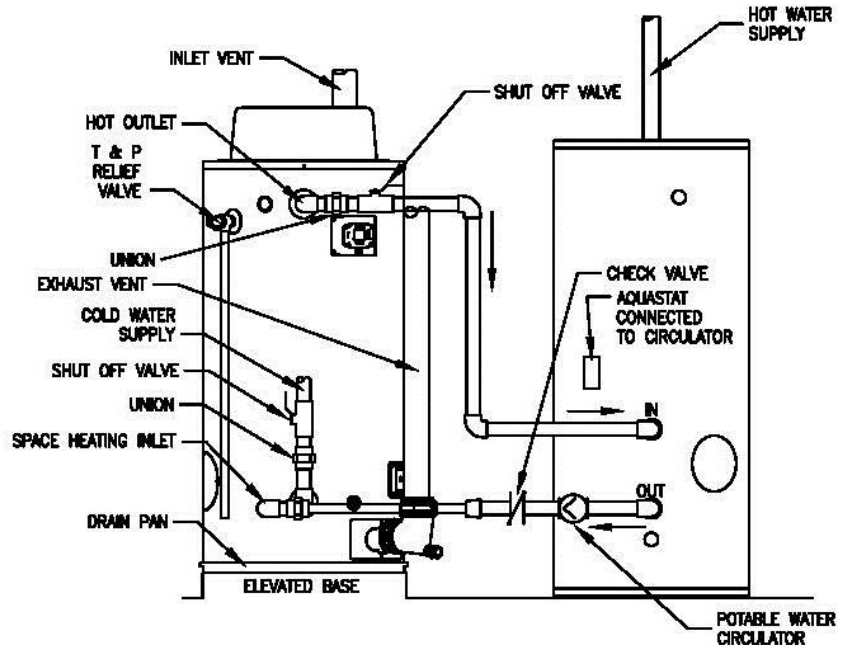


Figure 5 – Typical Front Inlet Connect with Storage Heater

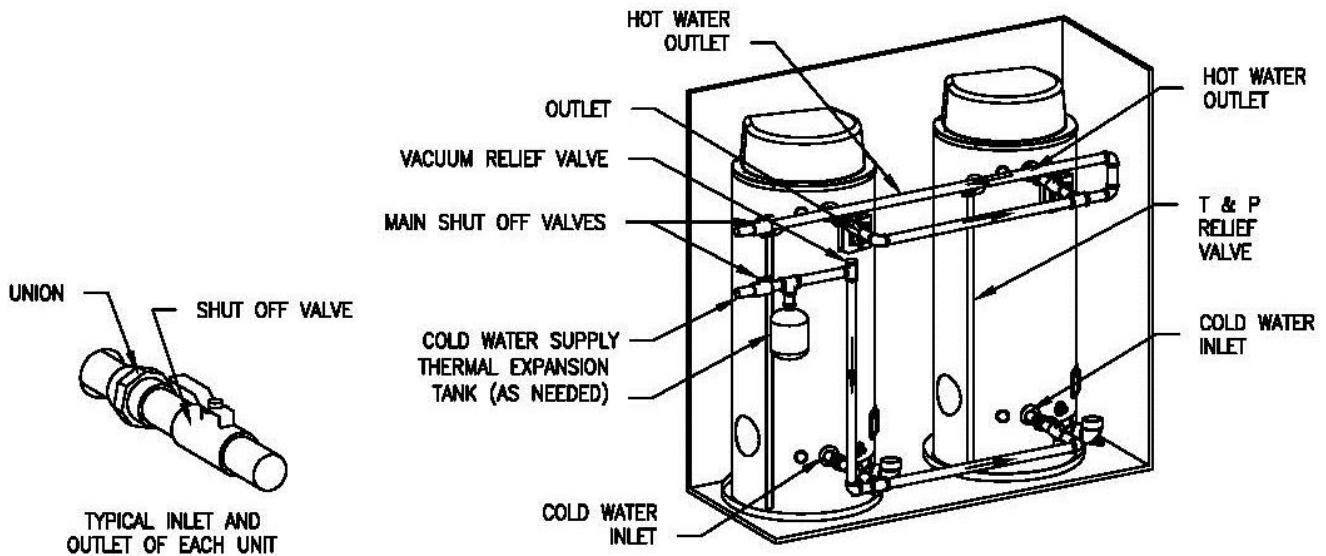


Figure 6 – Typical Two Water Heater Connection

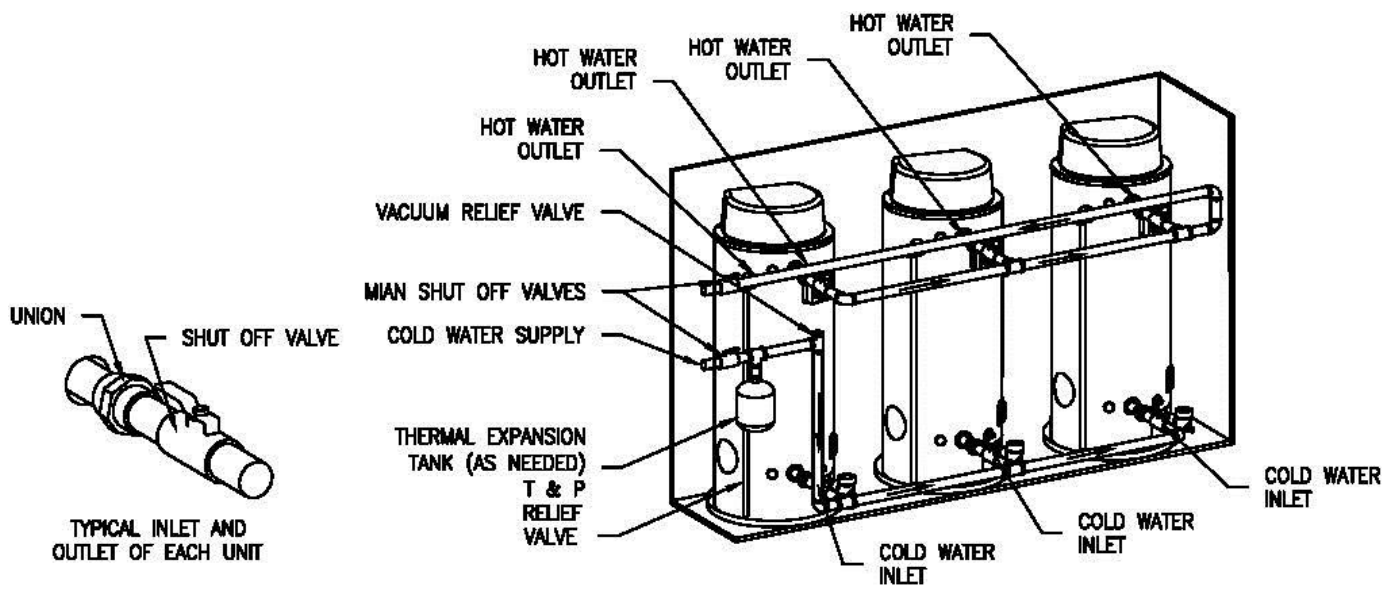


Figure 7 – Typical Three Water Heater Connection

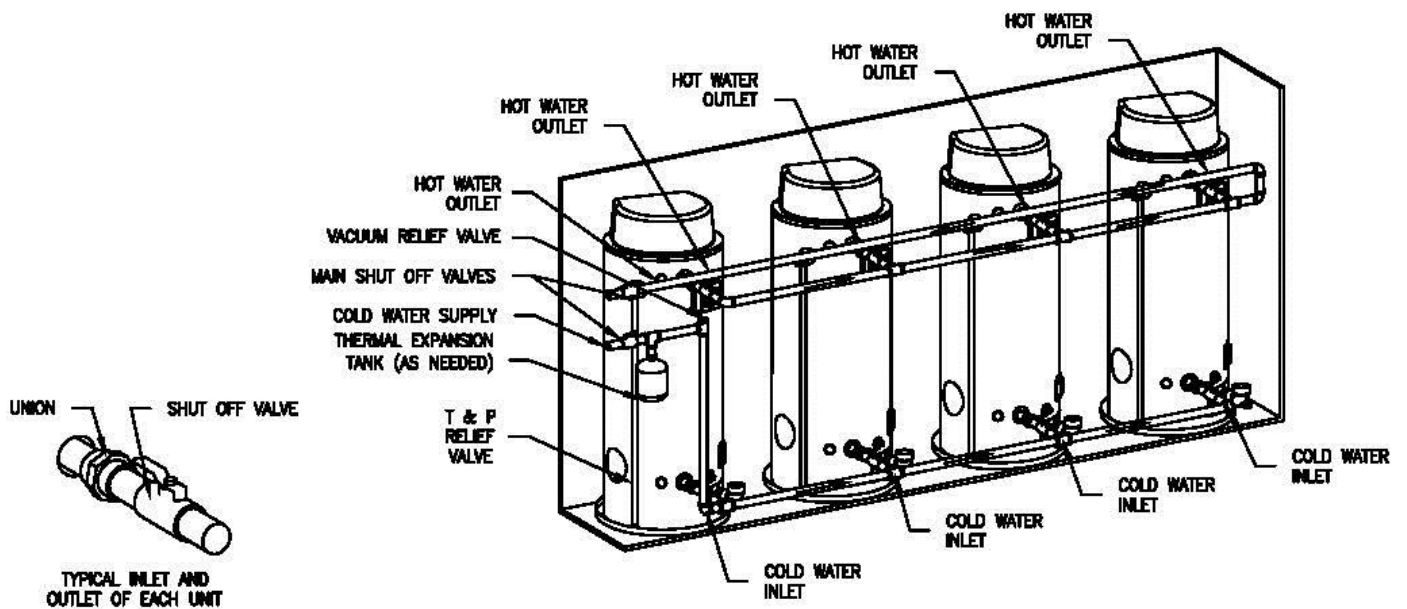


Figure 8 – Typical Four Water Heater Connection

**Note:** This drawing shows a suggested piping configuration and other devices; check with local codes and ordinances for additional requirements.

## SECTION V: WATER CONNECTIONS

### WARNING

Failure to install and maintain a new, listed temperature and pressure relief valve will release the manufacturer from any claim which might result from excessive temperature and pressures.

Hydrogen gas can be produced in an operating water heater that has not had water drawn from the tank for a long period of time (generally two weeks or more). **HYDROGEN GAS IS EXTREMELY FLAMMABLE.** To prevent the possibility of injury under these conditions, we recommend a hot water faucet to be open for several minutes before you use any electrical appliance, which is connected to the hot water system. If hydrogen is present, there will be an unusual sound such as air escaping through the pipes as hot water begins to flow. **DO NOT** smoke or have open flame near the faucet at the time it is open.

Keep clear of the combination temperature and pressure relief valve discharge line outlet. The discharge may be hot enough to cause scald injury. The water is under pressure and may splash.

### CAUTION

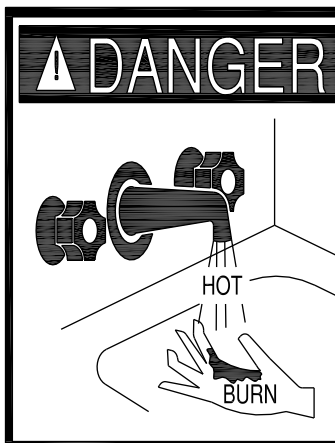
If sweat fittings are to be used, **DO NOT** apply heat to the nipples in front or side of the water heater. Sweat the tubing to the adapter before fitting the adapter to the water connections. It is imperative that heat is not applied to the nipples containing a plastic liner.

### Instructions for Connections

1. Before proceeding with the installation, **CLOSE** the main water supply valve. After shutting **OFF** the main water supply, open a faucet to relieve the water line pressure to prevent any water from leaking out of the pipes while making the water connections to the water heater. The **COLD** water inlet and **HOT** water outlet are identified on the water heater. Make the proper plumbing connections between the water heater and the plumbing system to the house. Install a shut-off valve in the cold water supply line.
2. If this water heater is installed in a closed water supply system, such as the one having a back-flow preventer in the cold water supply, provisions must be made to control thermal expansion. Do **NOT** operate this water heater in a closed system without provisions for controlling thermal expansion. Warranties do **NOT** cover damages from thermal expansion, such as pressure bulges and/or deformities. Your water supplier or local plumbing inspector should be contacted on how to control this situation.
3. After installation of the water lines, **OPEN** the main water supply valve and fill the water heater. While the water heater is filling, open several hot water faucets to allow air to escape from the water system. When a steady stream of water flows through the faucets, close them and check all water connections for possible leaks.
4. **NEVER** operate the water heater without first being certain it is filled with water.

### Scalding

This water heater can deliver scalding temperature water at any faucet in the system. Be careful whenever using hot water to avoid scalding injury. Certain appliances such as dishwashers and automatic clothes washers may require increased temperature water. By setting the thermostat on this water heater to obtain the increased temperature water required by these appliances, you might create the potential for scald injury. To protect against injury, you should install an ASSE approved mixing valve in the water system. This valve will reduce the point of discharge temperature by mixing cold and hot water in branch supply lines. Such valves are available from the manufacturer of this water heater or a local plumbing supplier. The following chart details the relationship of water temperature and time in regard to scald injury and may be used as a guide in determining the safest water temperature for your applications.

	<p>Water temperature over 125°F (52°C) can cause severe burns instantly or death from scalds.</p> <p>Children, disabled, and elderly are at highest risk of being scalded.</p> <p>Review this instruction manual before setting temperature at water heater.</p> <p>Feel water before bathing or showering.</p> <p>Temperature limiting valves are available, contact local plumbing supplier.</p>
--	--

The following chart details the relationship of water temperature and time in regard to scald injury and may be used as a guide in determining the safest water temperature for your applications.

**Table 2 – Approximate Time/Temperature Scald Chart**

<b>APPROXIMATE TIME/TEMPERATURE RELATIONSHIPS IN SCALDS</b>	
120°F (49°C)	More than 5 minutes
125°F (52°C)	1½ to 2 minutes
130°F (54°C)	About 30 seconds
135°F (57°C)	About 10 seconds
140°F (60°C)	Less than 5 seconds
145°F (63°C)	Less than 3 seconds
150°F (66°C)	About 1½ seconds
155°F (68°C)	About 1 second

**Alternate Space Heating Water Connections**

**⚠ DANGER**

Toxic chemicals, such as those used for boiler treatment, **must NOT** be introduced into potable water used for space heating.

This water heater **must NOT** be connected to an existing heating system or component(s) previously used with a non-potable water heating appliance.

All piping components connected to this water heater for space heating applications **must** be suitable for use with potable water.

This water heater has combination water/space heating connections and is **NOT** intended to be used in space heating only applications.

**⚠ WARNING**

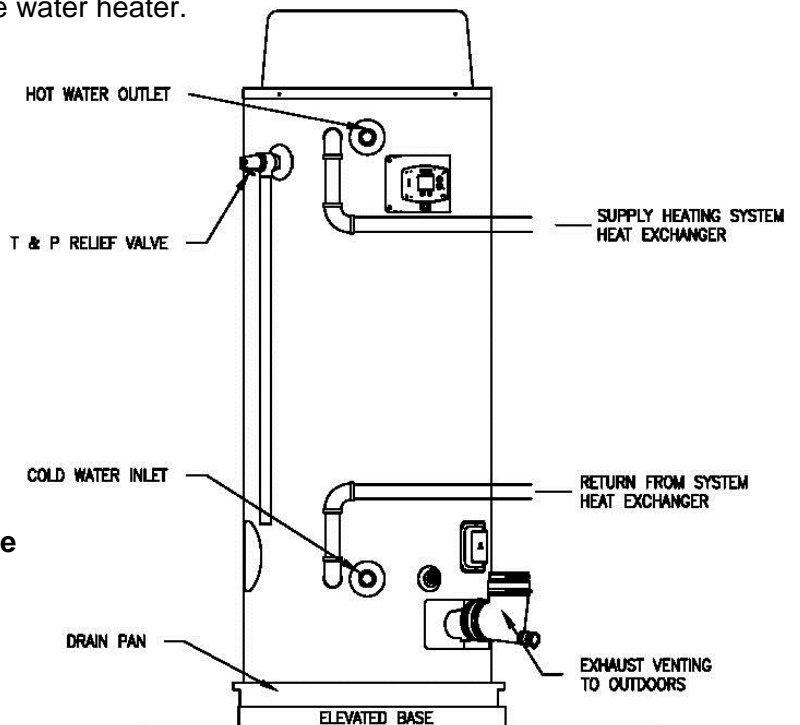
When the system requires water for space heating at temperatures higher than required for other uses, a means such as an ASSE approved mixing valve should be installed to temper the water for those uses in order to reduce scald hazard potential.

Failure to properly pipe this water heater may result in improper operation and damage to the water heater or structure.

Oxygen contamination of this water heater will cause corrosion of iron and steel components and can lead to water heater failure.

Connect the system supply and return piping to the water heater.

Refer to Figure 9 and Figure 10 for installation examples. Maintain a minimum 1/2 in (1.3 cm) clearance from hot water piping to combustible materials.



**Figure 9 – Alternate Space Heating Connections**



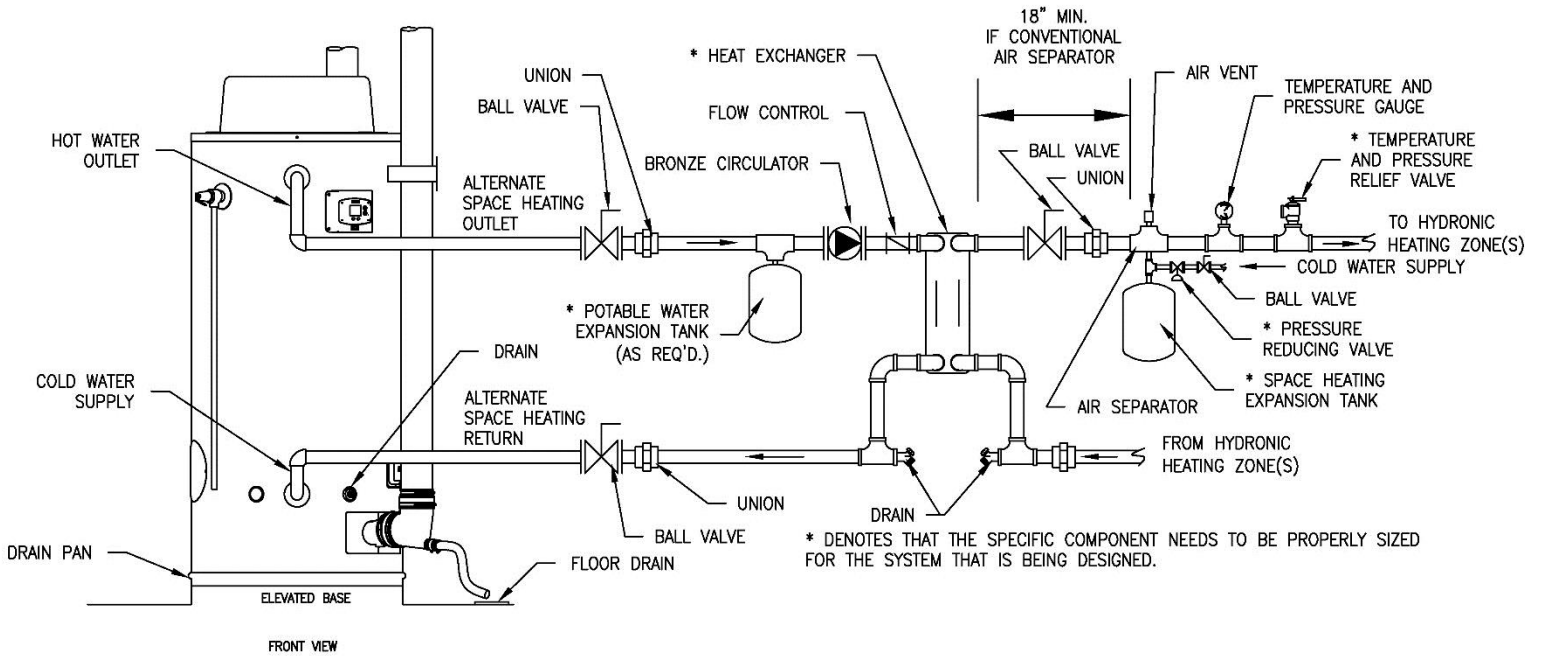


Figure 10 – Typical Plumbing Schematic for Zoned Heating

## SECTION VI: VENTING

### ⚠ WARNING

The vent system must be properly installed. Failure to properly install the vent system could result in property damage, personal injury, or death.

**DO NOT** install damaged venting system components. If damage is evident, contact the supplier where the water heater was purchased, or the manufacturer listed on the rating plate for replacement parts.

Use **only** the vent terminals provided or factory authorized terminals for venting this water heater.

The water heater requires its own separate venting system. **DO NOT** connect the exhaust vent into an existing vent pipe or chimney.

All of the exhaust venting connections must be leak checked with a soap solution upon initial startup of the water heater. Any leaks must be repaired before continuing operation of the water heater.

**DO NOT** terminate the venting where noise from the exhaust or intake will be objectionable. This includes locations close to or across from windows and doors. Avoid anchoring the vent and intake pipes directly to framed walls, floors, or ceilings unless rubber isolation pipe hangers are used. This prevents any vibrations from being transmitted into the living spaces.

**DO NOT** exceed the venting distances or the number of elbows listed in this manual. Exceeding the maximum venting distances may cause the water heater to malfunction or cause an unsafe condition.

**DO NOT** operate this water heater until the venting installation is complete and the piping completed. Failure to complete installation before operation can result in property damage, personal injury, or death.

### ⚠ WARNING

**Risk of carbon monoxide poisoning or fire due to joint separation or pipe breakage.**

This water heater **must** be properly vented and connected to an approved vent system in good condition. **DO NOT** operate the water heater with the absence of an approved vent system. A clean and unobstructed vent system is necessary to allow noxious fumes that could cause injury or loss of life to vent safely and will contribute toward maintaining the water heater's efficiency. The acceptance of the venting system is dependent upon full compliance with these installation instructions.

For installations in Canada, the venting system **must not** pass through fire rated separations.

The venting system **must** be free to expand and contract. This venting system **must** be supported in accordance with these instructions.

## NOTICE

For installations in Canada, field supplied vent piping must comply with CAN/CGA B149.1 (latest edition) and be certified to the Standard for Type BH, Class II, 65°C, Gas Venting Systems, ULC S636. Components of this listed system shall not be interchanged with other vent systems or unlisted pipe/fittings. All components and specified primers and cements of the certified vent system must be from a single system manufacturer and not intermixed with other system manufacturer's vent system parts. The supplied vent connector and vent termination are certified under ULC S636 and are also certified as part of the water heater. Refer to the following tables for approved venting materials, primers, and cements. All approved primers and cements are to be used within their marked time limitations.

### Approved Venting Materials

#### For installations in the US only

- DWV PVC Sch. 40 (ASTM D-2665)
- PVC Sch. 40 (ASTM-D1785)
- CPVC Sch. 40 (ASTM-F441, ASTM-D2846)
- PVC and CPVC (UL 1738, ULC S636)
- ABS Sch. 40 DWV (ASTM D2661)
- Polypropylene (UL 1738, ULC S636)
- Stainless Steel (UL 1738, ULC S636)

#### For installations in CANADA

- ULC S636 approved PVC for flue gas venting rated Class II, 65°C
- ULC S636 approved CPVC for flue gas venting rated Class II, 65°C
- ULC S636 approved Polypropylene for flue gas venting rated Class II, 65°C
- Stainless Steel (ULC S636)

### Approved Primers and Cements

#### For installations in the US only

- PVC and CPVC Primer (ASTM-F656)
- PVC Cement (ASTM D-2564)
- CPVC Cement (ASTM F493)
- ABS Primer and Cement (ASTM D-2235)

#### For installations in CANADA

- ULC S636 approved Primer and Cement for flue gas venting rated Class II, 65°C

## NOTICE

Use of cellular core PVC (ASTM F891), cellular core CPVC, or Radel® (polyphenosulfone) in non-metallic venting systems is prohibited and covering non-metallic venting with thermal insulation is prohibited.

## NOTICE

Before beginning installation of any vent pipe, read the vent pipe manufacturer's installation instructions.

**DO NOT** install the water heater in any location where the ambient temperature may fall below freezing. Water heater must be protected from freezing downdrafts during shutdown periods.

Provide protection of the building materials from degradation by flue gases from the exhaust vent terminal.

This water heater has a certified category IV, per latest ANSI Z 21.10.3-2019.CSA 4.3-2019 revision. Refer to the latest edition of the National Fuel Gas Code (ANSI Z223.1-latest edition), or in Canada, the Natural Gas and Propane installation Code (B149.1-00 latest edition).

## CAUTION

Check to make sure flue gases **DO NOT** recirculate into the air intake terminal when using direct venting. If the water heater is having service issues, flue recirculation may be a contributing factor. Even when the minimum vent terminal separation distances are followed, recirculation may still occur depending upon the location outside the building, the distance from other buildings, proximity to corners, weather conditions, wind patterns, and snow depth. Periodically check to make sure that flue recirculation is not occurring. Signs of flue gas recirculation include frosted or frozen intake terminals, condensate in the intake terminal and venting system, oxidation or white chalk material on the flame sensor or spark rod. Correction to flue recirculation may involve angling the intake away from the exhaust terminal, increasing the distance between them, relocating the air intake to another side of the building, or using inside air for combustion. Check to be sure the intake and exhaust terminals are not obstructed, especially during periods of below freezing weather.

All intake and exhaust venting components **must** have the same diameter size. **DO NOT** use a different size on the intake and exhaust venting. For 4 in (10.2 cm) venting, use the supplied 4 in (10.2 cm) vent terminals. For 3 in (7.6 cm) and 6 in (15.2 cm) venting, see the venting terminal section.

## CAUTION

Be sure the condensate runs freely to a drain and does not accumulate inside the water heater. In cold climates, precautions may need to be taken to ensure that the condensate drain does **NOT** freeze. Make sure a condensate trap or drain loop is installed to prevent flue gases from being discharged into the room. Refer to the Venting section of this Installation and Operation Manual for complete instructions on venting and condensate drainage.

High levels of dust and debris such as road and construction dust, insects, and tree pollen may clog the burner resulting in poor performance and damage to the water heater. Avoid air intake locations where debris can be created such as exhaust ventilation hoods, gravel parking lots, and near outdoor lights near vent terminals that attract bugs. For these installations, an air intake filter kit, is available as an accessory service part from the installer of this water heater. The air intake filter kit is **NOT** designed to filter out airborne contaminants or chemicals that may damage the water heater.

## CAUTION

The vent shall terminate a minimum of 12 in (30 cm) above expected snowfall level to prevent blockage of vent termination.

The horizontal centerline of the exhaust vent terminal (if applicable) **must NOT** be located lower than the horizontal centerline of the air intake terminal if vented through the same wall.

A service drain loop must be installed in the drain tubing to serve as a condensate trap to prevent flue gases from escaping into the room.

**DO NOT** position the air intake above the exhaust terminal.

**NEVER** locate the air intake where exhaust gases can be introduced.

## WARNING

To avoid damage or injury, there must be no materials stored against the water heater or vent-air intake system, and proper care must be taken to avoid unnecessary contact (especially by children) with the water heater and vent-air intake system. **UNDER NO CIRCUMSTANCES SHOULD FLAMMABLE MATERIALS, SUCH AS GASOLINE OR PAINT THINNER BE USED OR STORED IN THE VICINITY OF THIS WATER HEATER, VENT-AIR INTAKE SYSTEM OR IN ANY LOCATION FROM WHICH FUMES COULD REACH THE WATER HEATER OR VENT-AIR INTAKE SYSTEM.**

## Venting

The venting instructions must be followed to avoid poor combustion or recirculation of flue gases. Such conditions cause sooting or risks of fire and asphyxiation.

This water heater can be installed as either a power direct vent system or power vent system (air from inside). If it is installed as a power direct vent system, then the air intake and the exhaust vent are piped to the outside. If a power vent system is used, then combustion air is drawn from inside and only the exhaust is piped to the outside. Determine which system is best for your application and install as described in the following sections.

### Vent Intake/Exhaust Terminals

This water heater is supplied with a 4 in (10.2 cm) diameter screened intake elbow and exhaust coupling referred to as the 'air intake terminal' and the 'exhaust vent terminal.' These 4 in (10.2 cm) supplied vent terminals can be used with 4 in (10.2 cm) venting.

When venting with 6 in (15.2 cm) venting is desired, please discard 4 in (10.2 cm) vent terminals and use field supplied 6 in (15.2 cm) fittings instead.

It is recommended to use a screen with square openings of 1/4"x1/4" cut to a 7 1/2 in (19 cm) diameter circle. Then insert the screen into the field supplied intake/exhaust terminals.

When venting with 3 in (7.6 cm) venting is desired, please discard 4 in (10.2 cm) vent terminals and use field supplied 3 in (7.6 cm) fittings instead.

It is recommended to use a galvanized screen with square openings of 1/4"x1/4" cut to a 4 1/2 in (11.5 cm) diameter circle. Then insert the screen into the field supplied intake/exhaust terminals.

### Power Direct Vent Installation

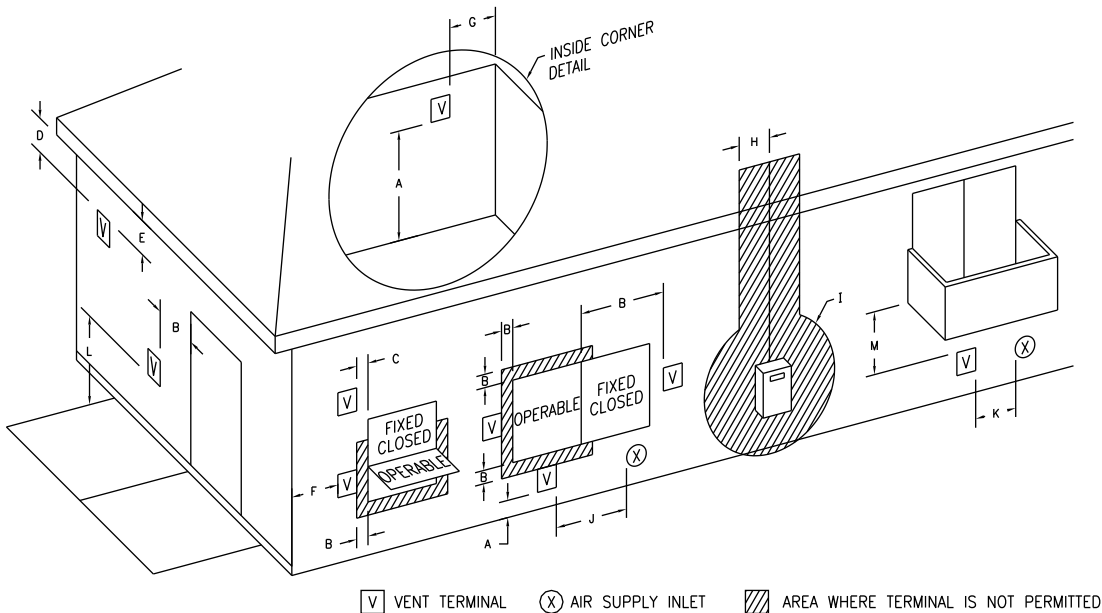
Venting may be run horizontally through an outside wall or vertically through a roof through using either 4 in (10.2 cm), 3 in (7.6 cm), or 6 in (15.2 cm) diameter pipe. This water heater is supplied with a screened intake elbow and exhaust coupling referred to as the 'air intake terminal' and the 'exhaust vent terminal.'

### Power Direct Vent Terminal Location

Plan the vent system layout so that proper clearances are maintained from plumbing and wiring. Before the vent is installed, determine the vent pipe termination location as shown in Figure 11.

## NOTICE

The air intake and exhaust terminals may be located on separate outside walls or one terminal may exit the roof while the other is through the wall. The total combined equivalent vent length must be within the limits specified in the venting tables and the intake length **CANNOT** exceed the exhaust by more than 30 ft (9.2 m). The minimum recommended vent separation distance between the intake and exhaust terminals is 36 in (91.5 cm). Local conditions may require a need for greater vent separation distances.



**Figure 11a – Vent Terminal Clearances (Other than Direct Vent or Powered Direct Vent Installations) (Power Vent, exhaust only)**

	Canadian Installations <sup>1</sup>	US Installations <sup>2</sup>		Canadian Installations <sup>1</sup>	US Installations <sup>2</sup>
<b>A=</b>	Clearance above grade, veranda, porch, deck or balcony	12 inches (30 cm)	<b>H=</b>	Clearance to each side of center line extended above meter/regulator assembly	3 feet (91 cm) within a height 15 feet (4.6 m) above the meter/regulator assembly
<b>B=</b>	Clearance to window or door that may be opened	6 in (15cm) for appliances ≤10,000 Btuh (3kW); 12 in (30 cm) for appliances >10,000 Btuh (3kW) and ≤100,000 Btuh (30kW); 36 in (91 cm) for appliances >100,000 Btuh (30 kW)	<b>I=</b>	Clearance to service regulator vent outlet or oil tank vent	36 inches (91 cm)
<b>C=</b>	Clearance to permanently closed window	*b	<b>J=</b>	Clearance to non-mechanical air supply inlet to building or the combustion air inlet to any other appliance	6 in (15cm) for appliances ≤10,000 Btuh (3kW); 12 in (30 cm) for appliances >10,000 Btuh (3kW) and ≤100,000 Btuh (30kW); 36 in (91 cm) for appliances >100,000 Btuh (30 kW)
<b>D=</b>	Vertical clearance to ventilated soffit located above the terminal within a horizontal distance of 2 feet (61 cm) from the center line of the terminal	*b	<b>K=</b>	Clearance to a mechanical air supply inlet	6 feet (1.83 m)
<b>E=</b>	Clearance to unventilated soffit	*b	<b>L=</b>	Clearance above paved sidewalk or paved driveway located on public property	7 feet (2.13 m) †
<b>F=</b>	Clearance to outside corner	*b	<b>M=</b>	Clearance under a veranda, porch, deck, or balcony	12 inches (30 cm) ‡
<b>G=</b>	Clearance to inside corner	36 inches (91 cm) *a			7 feet (2.13 m) †

<sup>1</sup> In accordance with the current CAN/CGA-B149 *Installation Codes*.

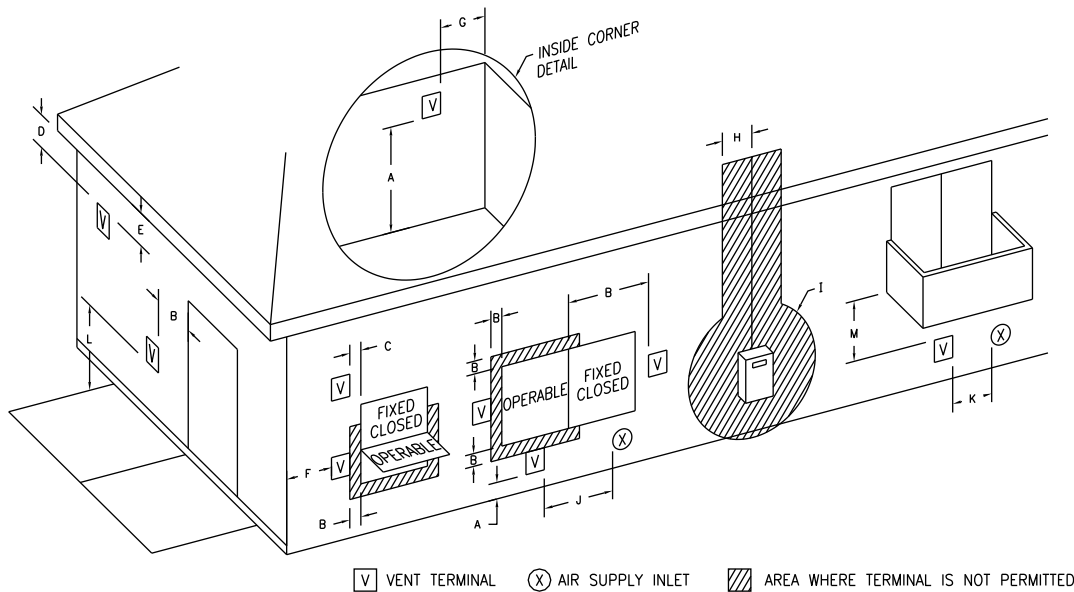
<sup>2</sup> In accordance with the current ANSI Z223.1-(Latest Edition)/NFPA 54 *National Fuel Gas Code*.

† A vent shall not terminate directly above a sidewalk or paved driveway that is located between two single-family dwellings and serves both dwellings.

‡ Permitted only if a veranda, porch, deck or balcony is fully open on a minimum of two sides beneath the floor.

\*a) A minimum clearance value determined by testing in accordance with section 2.20.

\*b) "Clearance in accordance with local installation codes and the requirements of the gas supplier".



**Figure 11b – Direct Vent and Powered Direct Vent Terminal Clearances  
(Power Direct Vent, intake and exhaust)**

	Canadian Installations <sup>1</sup>	US Installations <sup>2</sup>		Canadian Installations <sup>1</sup>	US Installations <sup>2</sup>
<b>A=</b>	Clearance above grade, veranda, porch, deck or balcony	12 inches (30 cm)		12 inches (30 cm)	
<b>B=</b>	Clearance to window or door that may be opened	6 in (15cm) for appliances ≤10,000 Btuh (3kW); 12 in (30 cm) for appliances >10,000 Btuh (3kW) and ≤100,000 Btuh (30kW); 36 in (91 cm) for appliances >100,000 Btuh (30 kW)		6 in (15 cm) for appliances ≤10,000 Btuh (3 kW); 9 in (23 cm) for appliances >10,000 Btuh (3 kW) and ≤ 50,000 Btuh (15 kW); 12 in (30 cm) for appliances >50,000 Btuh (15 kW)	
<b>C=</b>	Clearance to permanently closed window	*b		*b	
<b>D=</b>	Vertical clearance to ventilated soffit located above the terminal within a horizontal distance of 2 feet (61 cm) from the center line of the terminal	12 inches (30 cm) *a		12 inches (30 cm) *a	
<b>E=</b>	Clearance to unventilated soffit	12 inches (30 cm) *a		12 inches (30 cm) *a	
<b>F=</b>	Clearance to outside corner	*b		*b	
<b>G=</b>	Clearance to inside corner	36 inches (91 cm) *a		36 inches (91 cm) *a	
<b>H=</b>	Clearance to each side of center line extended above meter/regulator assembly				
<b>I=</b>	Clearance to service regulator vent outlet or oil tank vent			36 inches (91 cm)	*b
<b>J=</b>	Clearance to non-mechanical air supply inlet to building or the combustion air inlet to any other appliance			6 in (15cm) for appliances ≤10,000 Btuh (3kW); 12 in (30 cm) for appliances >10,000 Btuh (3kW) and ≤100,000 Btuh (30kW); 36 in (91 cm) for appliances >100,000 Btuh (30 kW)	6 in (15 cm) for appliances ≤10,000 Btuh (3 kW); 9 in (23 cm) for appliances >10,000 Btuh (3 kW) and ≤ 50,000 Btuh (15 kW); 12 in (30 cm) for appliances >50,000 Btuh (15 kW)
<b>K=</b>	Clearance to a mechanical air supply inlet			6 feet (1.83 m)	3 feet (91 cm) above if within 10 feet (3.1 m) horizontally
<b>L=</b>	Clearance above paved sidewalk or paved driveway located on public property			7 feet (2.13 m) †	*b
<b>M=</b>	Clearance under a veranda, porch, deck, or balcony			12 inches (30 cm) ‡	12 inches (30 cm) ‡

<sup>1</sup> In accordance with the current CAN/CGA-B149 *Installation Codes*.

<sup>2</sup> In accordance with the current ANSI Z223.1-(Latest Edition)/NFPA 54 *National Fuel Gas Code*.

† A vent shall not terminate directly above a sidewalk or paved driveway that is located between two single-family dwellings and serves both dwellings.

‡ Permitted only if a veranda, porch, deck or balcony is fully open on a minimum of two sides beneath the floor.

\*a) A minimum clearance value determined by testing in accordance with section 2.20.

\*b) "Clearance in accordance with local installation codes and the requirements of the gas supplier".

The vent system must terminate so that proper clearances are maintained as cited in local codes or the latest edition of the National Fuel Gas Code, ANSI Z223.1:

1. Do not terminate near soffit vents or crawl space or other area where condensate or vapor could create a nuisance or hazard or cause property damage.
2. Do not terminate the exhaust vent terminal where condensate or vapor could cause damage or could be detrimental to the operation of regulators, relief valves, or other equipment.
3. Do not terminate the exhaust vent terminal over public area or walkways where condensate or vapor can cause nuisance or hazard.
4. The vent shall terminate a minimum of 12 inches above expected snowfall level to prevent blockage of vent termination.
5. The manufacturer requires the centerline distances between the air intake and exhaust vent terminals to be a minimum of 36 inches apart and the exhaust terminal must extend 6 inches past the air intake terminal.

Vent pipes serving power vented appliances are classified by building codes as “vent connectors.” Required clearances from combustible materials must be provided in accordance with information in this manual under Locating the Water Heater and Clearances, and with National Fuel Gas Code and local codes.

<b>Clearance to combustibles for all venting pipes and terminals</b>	
<b><u>For installations in the US</u></b> 0” minimum	<b><u>For installations in the CANADA</u></b> Refer to vent pipe and terminal manufacturer’s installation instructions for clearances to combustibles.
<b>DO NOT</b> place insulation or other materials in the required clearance spaces between the venting to combustible material unless otherwise specified.	

### Horizontal Installation

In a horizontal application, it is important that condensate **NOT** be allowed to buildup in the exhaust vent pipe. To prevent this from happening, the pipe should be installed with a slight upward slope, so the condensate will run back toward the water heater. The vent system **must** be supported every 5 ft (1.5 m) of vertical run and every 3 ft (.92 m) of horizontal run of vent pipe length.

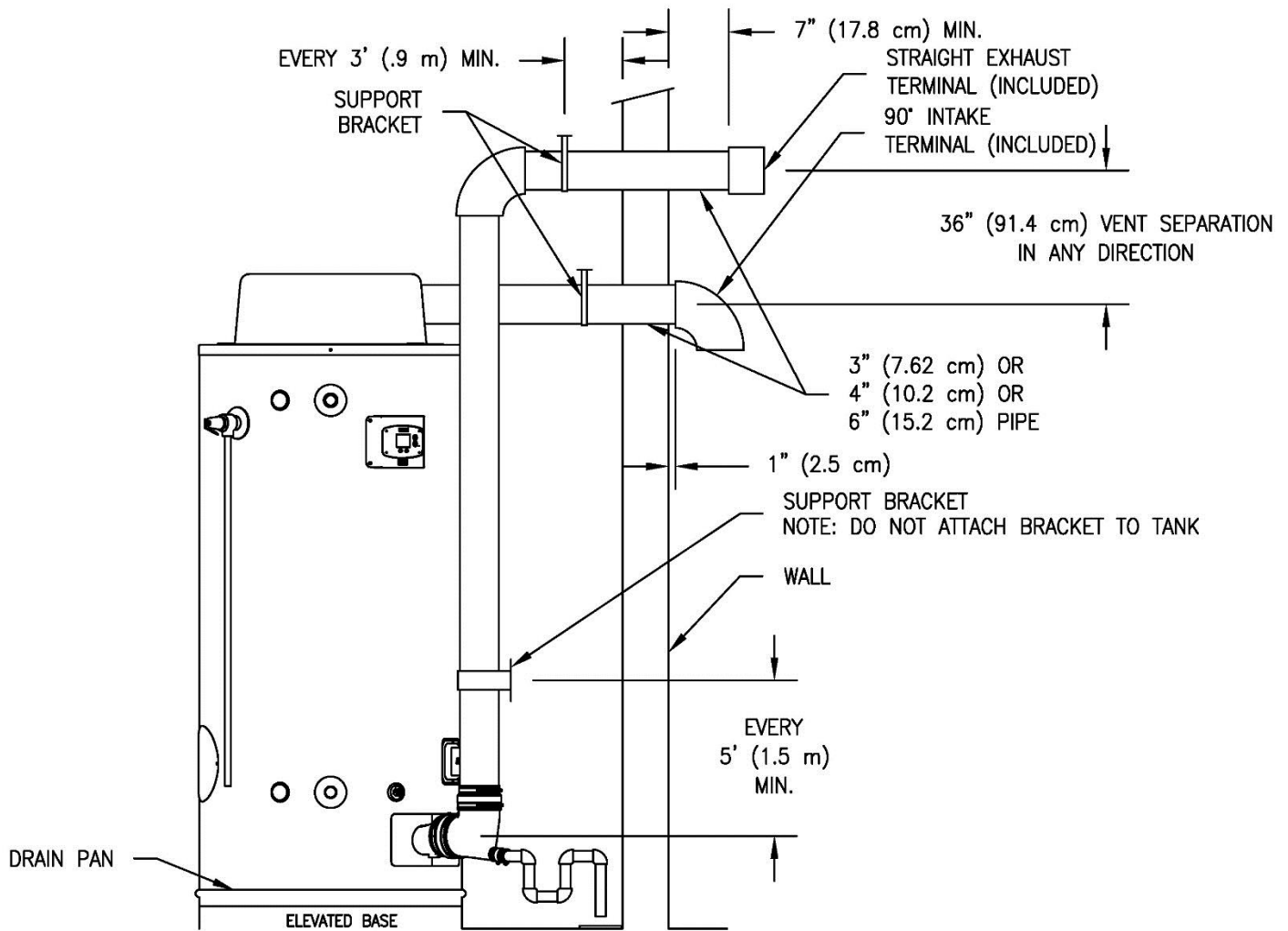
 **CAUTION**

Failure to properly support the vent piping with hangers and clamps may result in damage to the water heater or venting system.

Stress levels in the pipe and fittings can be significantly increased by improper installation. If rigid pipe clamps are used to hold the pipe in place, or if the pipe cannot move freely through a wall penetration, the pipe may be directly stressed, or high thermal stresses may be formed when the pipe heats up and expands. Install accordingly to minimize such stresses.

Follow the following procedure for power direct venting through the wall:

1. Cut two 4 ½ in (11.4 cm) diameter holes for 4 in (10.2 cm) diameter pipe, two 3 ½ in (8.9 cm) diameter holes for 3 in (7.6 cm) diameter pipe, or two 6 5/8 in (16.9 cm) diameter holes for 6 in (15.2 cm) diameter pipe in the wall. The centerline hole distances **must** be at least 36 in (91.4 cm) apart in the location where the exhaust vent and air intake terminals will exit the outside wall, if vented on the same wall.
2. Use the proper cement to secure the exhaust vent and air intake terminals provided with the water heater to the pipes. The distance between the back edge of the exhaust vent terminal and the exterior wall (see Figure 12) must be 6 in (15.2 cm) more for the exhaust vent terminal than the air intake terminal. Use the proper cement or sealant and assembly procedures to secure the vent connector joints between the terminal and the blower outlet. Provide support brackets for every 3 ft (.92 m) of horizontal vent beyond the intake terminal.



**Figure 12 – Typical Horizontal Power Direct Vent System**

### Vertical Installation

Vertical venting system **must** be supported every 5 ft (1.5 m) of vertical run and every 3 ft (.92 m) of horizontal run of vent pipe length.

## ⚠ CAUTION

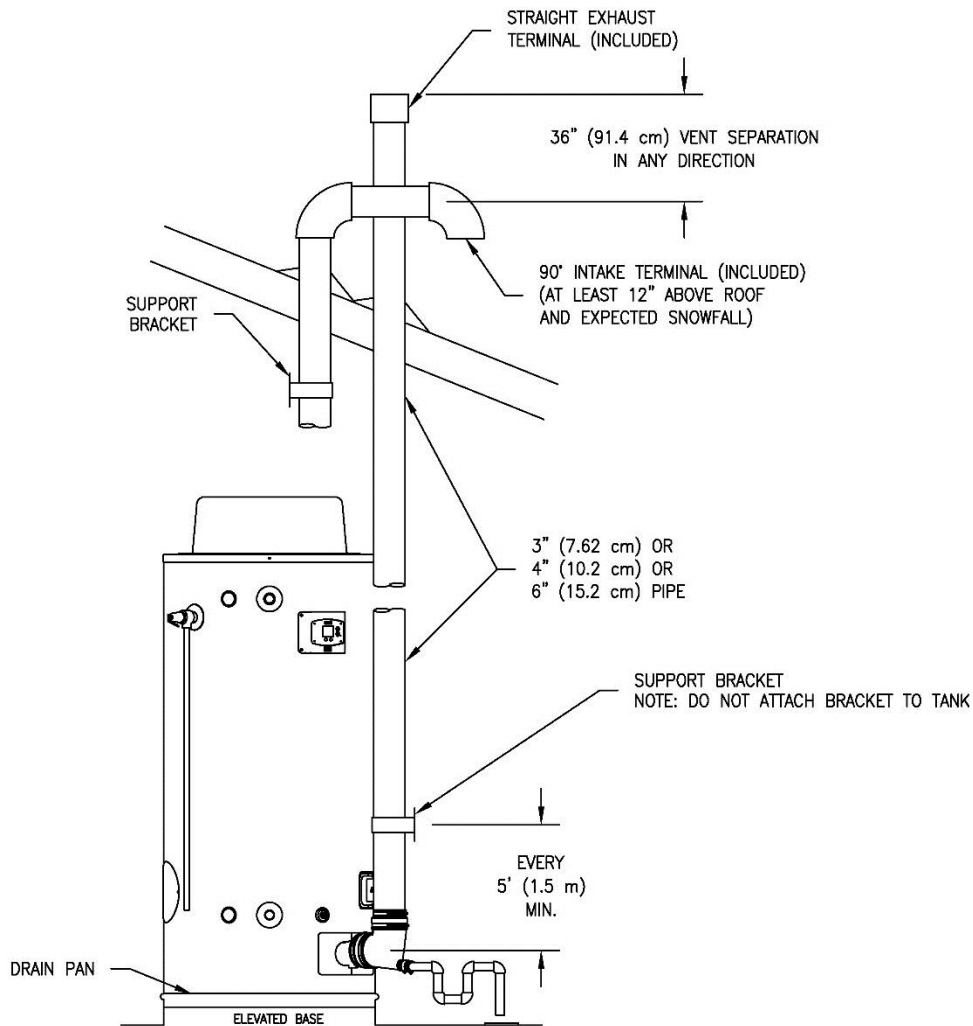
Failure to properly support the vent piping with hangers and clamps may result in damage to the water heater or venting system.

Stress levels in the pipe and fittings can be significantly increased by improper installation. If rigid pipe clamps are used to hold the pipe in place or if the pipe cannot move freely through a wall penetration, the pipe may be directly stressed, or high thermal stresses may be formed when the pipe heats up and expands. Install accordingly to minimize such stresses.

Follow the following procedure for direct venting through the roof:

1. Cut the necessary holes through the roof and ceiling. Cut two 4 ½ in (11.4 cm) diameter holes for 4 in (10.2 cm) diameter pipe, two 3 ½ in (8.9 cm) diameter holes for 3 in (7.6 cm) diameter pipe, or 6 5/8 in (16.9 cm) diameter holes for 6 in (15.2 cm) diameter pipe in the ceiling and roof.
2. Install the exhaust vent and air intake plastic pipes as shown in Figure 13. Make sure that the installation meets the local codes and/or The National Fuel Gas Code ANSI Z223.1 (Latest Edition) or CGA/CAN B149 Installation Code.

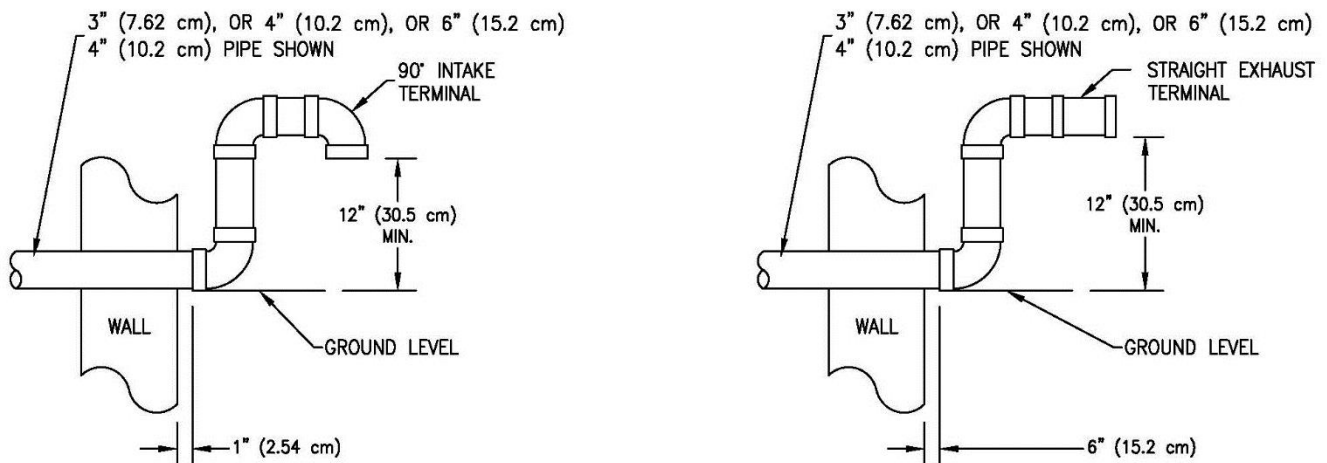




**Figure 13 – Typical Vertical Power Direct Vent System Installation**  
(Intake and exhaust terminals may be on different outside walls)

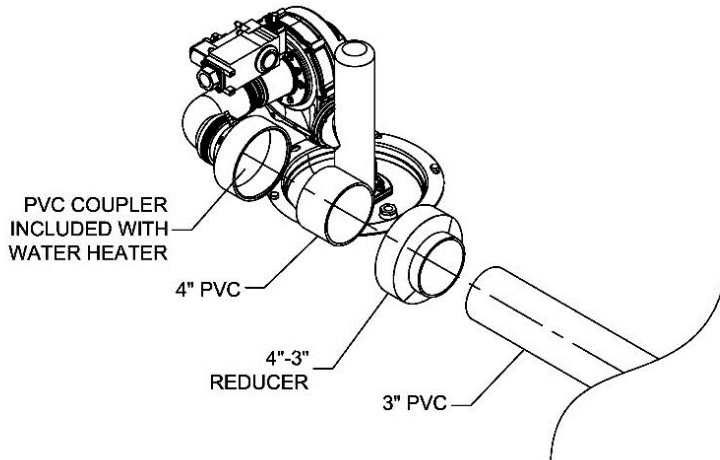
### Through the Wall Venting with Low Ground Clearance

When venting cannot exit through the wall at a height greater than or equal to 12 in (30.5 cm) (and above expected snow level) from the ground, then the installation **must** be modified as shown below (see Figure 14). Refer to Table 3 (page 27) for maximum venting lengths using 4 in (10.2 cm), or 6 in (15.2 cm) diameter plastic pipe. When using low ground clearance venting there still needs to be 36 in (91.5 cm) of vent separation between intake and exhaust vent terminations.



**Figure 14 – Vent Terminal (Low Ground Clearance)**

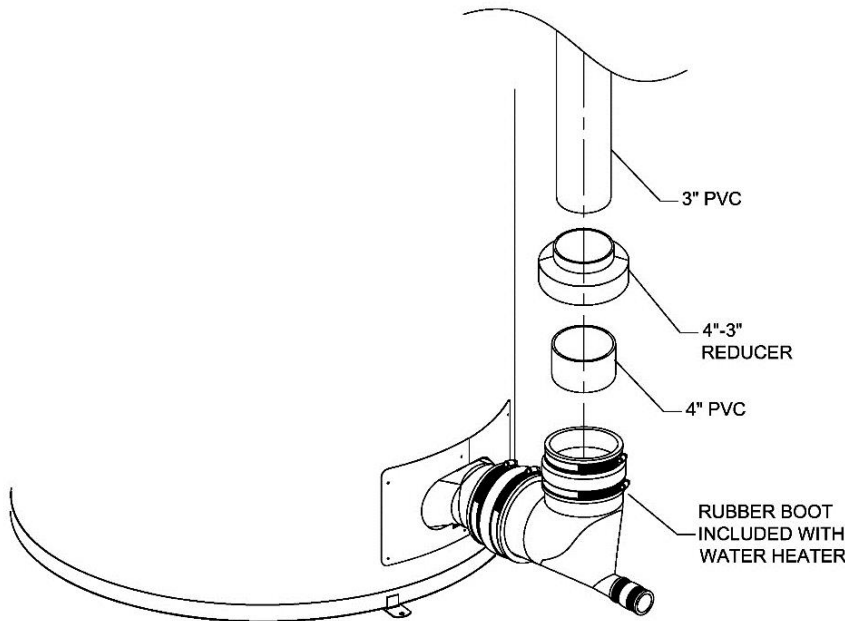
### 3 inch Venting Installation



**IMPORTANT**  
All of the venting connections **must be** leak checked with a soap and water solution upon initial start-up of the water heater. Any leaks **must be** repaired before continuing operation of the water heater.

3" INTAKE VENTING INSTALL  
Top of Tank

Figure 15 – 3"  
Venting Installation



3" EXHAUST VENTING INSTALL  
Bottom of Tank

**Note:** Use a 4" (10.1 cm) to 3" (7.6 cm) reducer and exit the building wall with 3" (7.6 cm) vent pipe using a 3" (7.6 cm) 90° vent terminal. Two 45° elbows are equivalent to one 90° elbow.

**⚠ WARNING**  
USE 4" CONNECTORS THAT WERE SUPPLIED WITH THE HEATER BEFORE REDUCING DOWN TO 3".

## Maximum Vent Length

**Table 3 – Power Direct Vent and Power Vent Maximum Vent Length  
(Combined Maximum Length for Intake and Exhaust)**

	120T4003N(A) 399,999 BTU/hr		120T5003N(A) 499,000 BTU/hr	
<b>3 in. Vent Pipe</b>	<b>Power Direct Vent</b>	<b>Power Vent</b>	<b>Power Direct Vent</b>	<b>Power Vent</b>
Max. Intake Length	65 ft.	N/A	65 ft.	N/A
Max. Exhaust Length	65 ft.	65 ft.	65 ft.	65 ft.
<b>4 in. Vent Pipe</b>	<b>Power Direct Vent</b>	<b>Power Vent</b>	<b>Power Direct Vent</b>	<b>Power Vent</b>
Max. Intake Length	100 ft.	N/A	100 ft.	N/A
Max. Exhaust Length	100 ft.	100 ft.	100 ft.	100 ft.
<b>6 in. Vent Pipe</b>	<b>Power Direct Vent</b>	<b>Power Vent</b>	<b>Power Direct Vent</b>	<b>Power Vent</b>
Max. Intake Length	120 ft.	N/A	120 ft.	N/A
Max. Exhaust Length	120 ft.	120 ft.	120 ft.	120 ft.

### SI UNIT Equivalent

	120T4003N(A) 399,999 BTU/hr		120T5003N(A) 499,000 BTU/hr	
<b>3 in. Vent Pipe</b>	<b>Power Direct Vent</b>	<b>Power Vent</b>	<b>Power Direct Vent</b>	<b>Power Vent</b>
Max. Intake Length	19.8 m	N/A	19.8 m	N/A
Max. Exhaust Length	19.8 m	19.8 m	19.8 m	19.8 m
<b>4 in. Vent Pipe</b>	<b>Power Direct Vent</b>	<b>Power Vent</b>	<b>Power Direct Vent</b>	<b>Power Vent</b>
Max. Intake Length	30.5 m	N/A	30.5 m	N/A
Max. Exhaust Length	30.5 m	30.5 m	30.5 m	30.5 m
<b>6 in. Vent Pipe</b>	<b>Power Direct Vent</b>	<b>Power Vent</b>	<b>Power Direct Vent</b>	<b>Power Vent</b>
Max. Intake Length	36.6 m	N/A	36.6 m	N/A
Max. Exhaust Length	36.6 m	36.6 m	36.6 m	36.6 m

**Note:** The venting distance shown in the charts above is the combined maximum distance for the intake and exhaust pipe and elbows. The intake and exhaust vent terminals may be in different locations (i.e., different walls or one wall, one roof) provided that the intake equivalent venting distance does not exceed the exhaust by more than 30 ft (9.2 m).

### Determining Required Vent Length

1. Determine the total length of straight vent pipe (in feet) required for both the intake and the exhaust.
2. Add 5 ft (1.52 m) of venting for every 90° elbow.
3. Add 2 ½ ft (.76 m) of venting for every 45° elbow.
4. **Total vent length CANNOT exceed maximum vent length in Table 3.**
5. **Air intake CANNOT exceed exhaust by more than 30 ft (9.2 m) in any venting situation.**

### Example of Total Power Direct Vent Length for 120T400:

A 4 in (10.2 cm) venting system has a total of six 90° elbows and a total straight pipe length of 65 ft (19.8 m) (includes both intake and exhaust pipe). Equivalent vent length for elbows: 6 x 5 ft = 30 ft (9.2 m). **Total equivalent vent distance = 65 ft (19.8 m) + 30 ft (9.2 m) = 95 ft (29 m) total equivalent vent length. This is below the maximum allowed distance of 200 feet for this model using 4 in (10.2 cm) vent.**

## NOTICE

**DO NOT** include the 4 in (10.2 cm) condensate elbow or vent terminals in determining maximum vent length.

## Power Vent Installation

Power venting is where the indoor air is used, and the exhaust is vented to the outside. Venting may be run horizontally through an outside wall or vertically through a roof through using either 4 in (10.2 cm), 3 in (7.6 cm), or 6 in (15.2 cm) diameter pipe.

## Power Vent Terminal Location

Refer to the “Direct Vent Terminal Location” section previously mentioned to determine the proper exhaust vent location. Plan the vent system layout so that proper clearances are maintained from plumbing and wiring. Vent pipes serving power vented appliances are classified by building codes as vent connectors. Required clearances from combustible materials must be provided in accordance with information in this manual under Locating the Water Heater, Clearances, and with the National Fuel Gas Code and local codes.

### Clearance to combustibles for all venting pipes and terminals

#### For installations in the US

0” minimum

#### For installations in CANADA

Refer to vent pipe and terminal manufacturer’s installation instructions for clearances to combustibles.

**DO NOT** place insulation or other materials in the required clearance spaces between the venting to combustible material unless otherwise specified.

## Horizontal Installation

In a horizontal application, it is important that condensate not be allowed to buildup in the exhaust vent pipe. To prevent this from happening, the pipe should be installed with a slight upward slope of 1/4 in. per ft. The vent system **must be** supported every 5 ft (1.5 m) of vertical run and every 3 ft (.92 m) of horizontal run of vent pipe length.

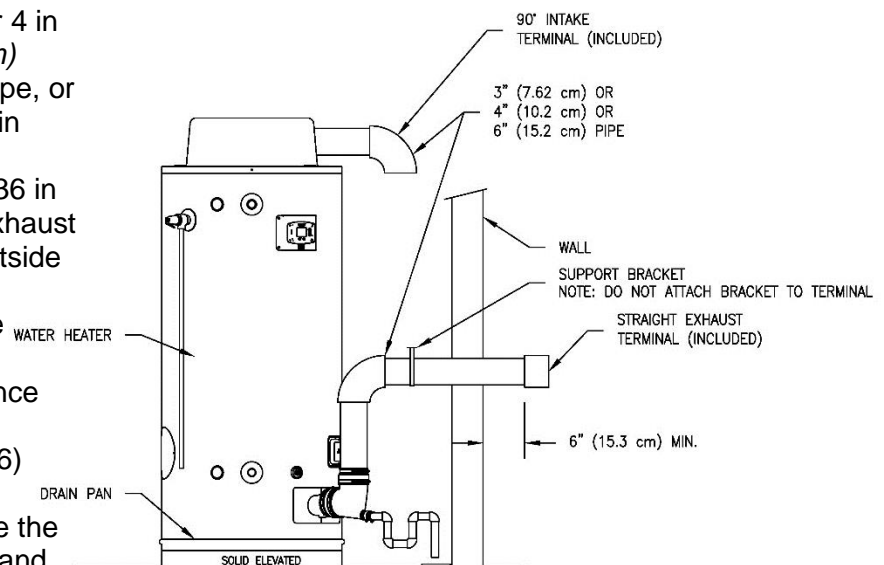
## CAUTION

Failure to properly support the vent piping with hangers and clamps may result in damage to the water heater or venting system.

Stress levels in the pipe and fittings can be significantly increased by improper installation. If rigid pipe clamps are used to hold the pipe in place, or if the pipe cannot move freely through a wall penetration, the pipe may be directly stressed, or high thermal stresses may be formed when the pipe heats up and expands. Install accordingly to minimize such stresses.

Follow the procedure below to vent through the wall:

1. Cut two 4 ½ in (11.5 cm) diameter holes for 4 in (10.2 cm) diameter pipe, two 3 ½ in (8.9 cm) diameter holes for 3 in (7.6 cm) diameter pipe, or two 6 5/8 in (16.9 cm) diameter holes for 6 in (15.2 cm) diameter pipe in the wall. The centerline hole distances **must** be at least 36 in (91.4 cm) apart in the location where the exhaust vent and air intake terminals will exit the outside wall, if vented on the same wall.
2. Use the proper cement or sealant to secure the exhaust vent terminal provided with the water heater to the plastic pipes. The distance between the back edge of the exhaust vent terminal and the exterior wall (see Figure 16) must be 6 in (15.2 cm). Use the proper cement and assembly procedures to secure the vent connector joints between the terminal and the blower outlet. Provide support brackets for every 3 ft (.92 m) of horizontal vent.



**Figure 16 – Typical Horizontal Power Vent System**

## Vertical Installation

Vertical venting **must be** supported every 5 ft (1.5 m) of vertical run and every 3 ft (.92 m) of horizontal run of vent pipe length.

Stress levels in the pipe and fittings can be significantly increased by improper installation. If rigid pipe clamps are used to hold the pipe in place or if the pipe cannot move freely through a wall penetration, the pipe may be directly stressed, or high thermal stresses may be formed when the pipe heats up and expands. Install accordingly to minimize such stresses.

### CAUTION

Failure to properly support the vent piping with hangers and clamps may result in damage to the water heater or venting system.

Follow the procedure below to vent through the roof:

1. Cut the necessary holes through the roof and ceiling. Cut one 4 ½ in (11.5 cm) diameter hole for 4 in (10.2 cm) diameter pipe, one 3 ½ in (8.9 cm) diameter holes for 3 in (7.6 cm) diameter pipe, or one 6 5/8 in (16.9 cm) for 6 in (15.2 cm) diameter pipe.
2. Install the exhaust vent and air intake plastic pipes as shown in Figure 17. Make sure that the installation meets the local codes and/or The National Fuel Gas Code ANSI Z223.1 (Latest Edition) or CGA/CAN B149 Installation Code.

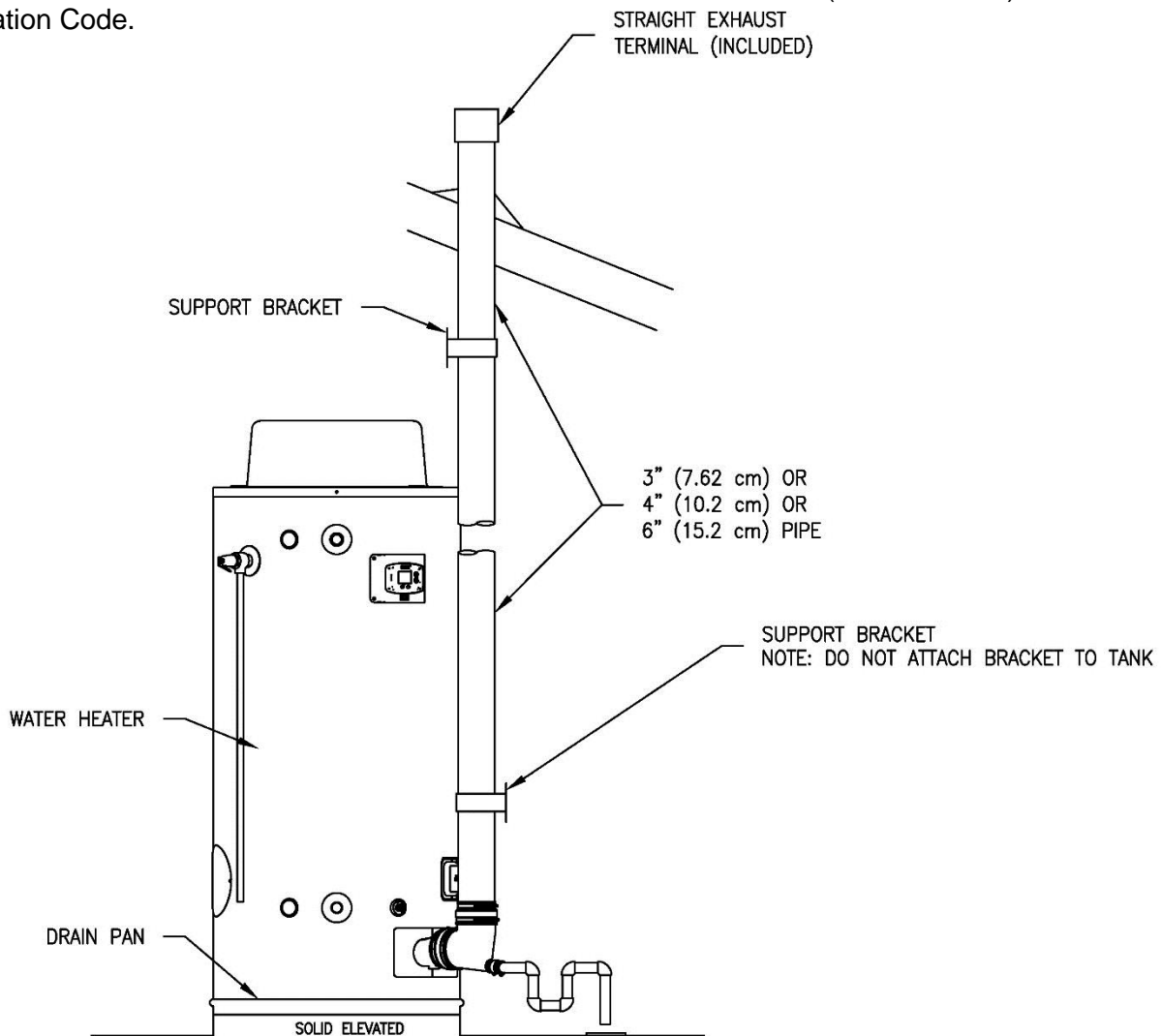


Figure 17 – Typical Vertical Power Vent System Installation

## Through the Wall Venting with Low Ground Clearance

When venting cannot exit through the wall at a height greater than or equal to 12 in (30 cm) from the ground and 12 in (30 cm) above expected snowfall, then the installation must be modified as shown below (see Figure 18). Refer to Table 3 (page 27) for maximum venting lengths using 4 in (10.2 cm) or 6 in (15.2 cm) diameter plastic pipe.

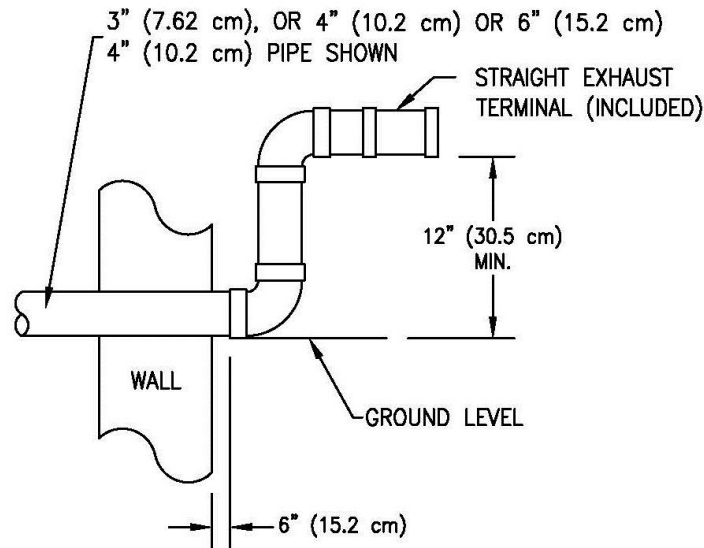


Figure 18 – Vent Terminal (Low Ground Clearance)

## Maximum Vent Length Determination

Reference Table 3 on page 27 for Maximum Vent Length Tables.

### Determining Required Vent Length

1. Determine the total length of straight vent pipe (in feet) required.
2. Add 5 ft (1.5 m) of venting for every 90° elbow.
3. Add 2 ½ ft (.76 m) of venting for every 45° elbow.
4. **Total vent length cannot exceed maximum vent length in Table 3.**

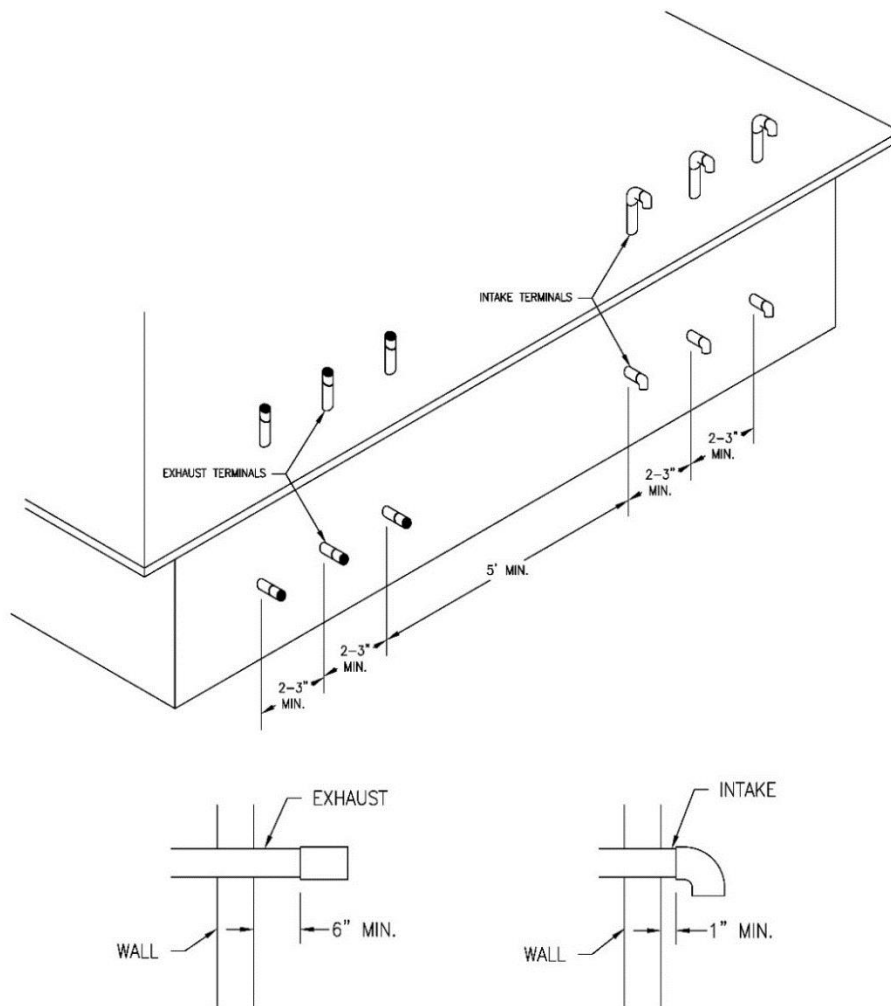
### Example Of Total Vent Length For 120T400 With A Power Vented Installation

A 3 in (7.6 cm) venting system has a total of six 90° elbows and a total straight pipe length of 35 ft (10.7 m).  
Equivalent vent length for elbows: 6 x 5 feet = 30 feet (9.2 m).

**Total equivalent vent distance = 35 feet + 30 feet = 65 feet (19.8 m) total equivalent vent length. This is below/equal to the maximum allowed distance of 65 feet (19.8 m) for this model using 3" vent.**

## NOTICE

**DO NOT** include the 3 in (7.6 cm) condensate elbow or vent terminals in determining maximum vent length.



**Figure 19 – Multiple Intake/Exhaust Terminal Separation Distances**

**Note:** When installing multiple intake/exhaust terminals on the same wall of a building, the nearest intake terminal must be at least 5 ft (1.5 m) from the nearest exhaust terminal. Spacing requirements are the same for roof installation.

### Concentric Vent Terminal Installation Procedure

#### **WARNING**

Improper installation, adjustment, service, or maintenance can cause property damage, personal injury, or death. Consult a qualified installer, service agency, or the gas supplier for information or assistance.

This concentric terminal must be used only for terminating this water heater. **DO NOT** use this concentric terminal kit for any other appliance. Using this concentric terminal on other appliances and/or water heaters can result in property damage, personal injury, or death.

**DO NOT** operate this water heater until the installation and assembly of this concentric terminal is complete and the piping is completed. Failure to complete installation before operation can result in property damage, personal injury, or death.

Before beginning any installation, be sure the main electrical disconnect switch is in the OFF position. Electrical shock can cause personal injury or death.

**DO NOT** operate this water heater with the rain cap removed or recirculation of combustion products may occur. Water may also collect inside larger combustion-air pipe and flow to the burner assembly. Failure to follow this warning could result in product damage, or improper operation, personal injury or death.

#### **CAUTION**

**DO NOT** use field-supplied couplings to extend pipes. Airflow restriction will occur, and the water heater pressure switches may cause intermittent problems.

## Vertical Installation (recommended)

Table 4 – Approved IPEX Concentric Terminals

Bradford White Appliance Numbers Approved for Concentric Termination Kits	Description	Bradford White Part Number	IPEX System (1738 or 636)	IPEX Part Number
120T(400,500)	3" Concentric Termination	239-44069-01	636	196006 (PVC), 197009 (CPVC)
120T(400,500)	3" Concentric Termination	---	1738	397006
120T(400,500)	4" Concentric Termination	---	636	196021 (PVC), 197021 (CPVC)
120T(400,500)	4" Concentric Termination	---	1738	397021

### Deduct 30 ft (9.2 m) for 3" concentric terminal ONLY for the 120T(400,500).

**Note:** The vent length **must** be reduced by 30 ft (9.2 m) when using 3 in (7.6 cm) concentric terminals, for a maximum 3 in (7.6 cm) combined vent length of 100 ft (30.5 m). There is **NO** reduction in vent length when using 4 in (10.2 cm) concentric terminals, for a maximum 4 in (10.2 cm) combined vent length of 200 ft (61 m) plus the 4 in (10.2 cm) concentric terminal.

1. Become familiar with the approved concentric terminals listed in Table 4. Refer to instructions inside concentric vent kit. Refer to the previous section on determining the maximum venting distance and pipe diameter required for the installation.

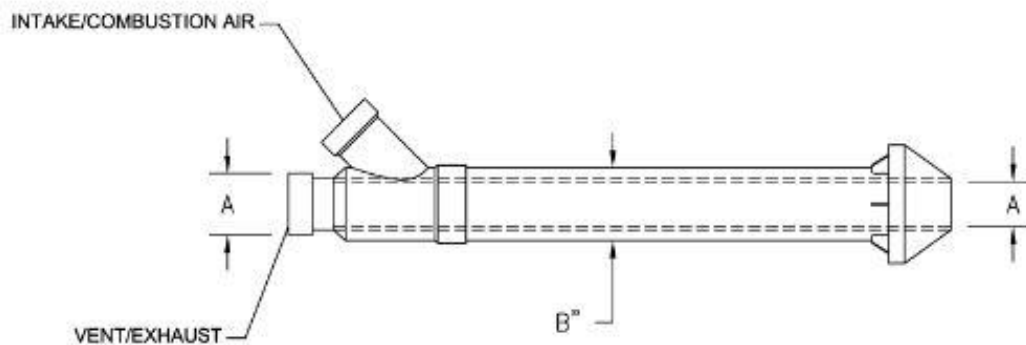


Figure 20 - Dimensional Layout of 3" & 4" Concentric Vent Kits

Concentric Vent Size	(A) Nominal Pipe Size	(B) in inches
4 in	4 in	6 5/8 in
3 in	3 in	4 1/2 in

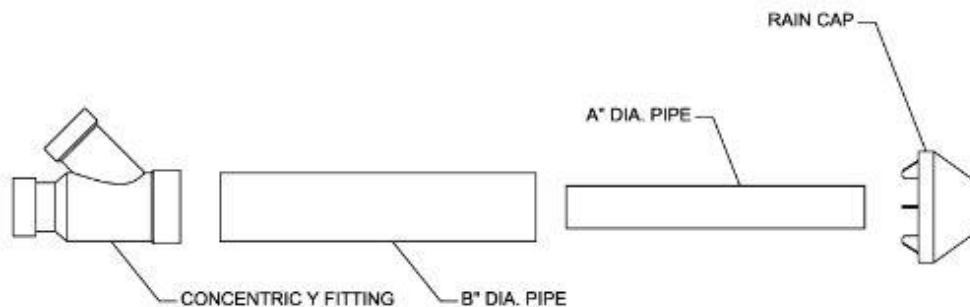


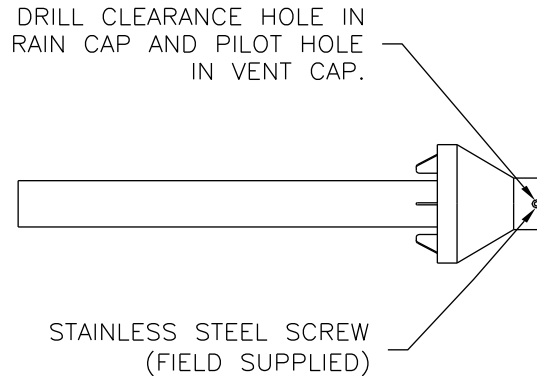
Figure 21 – 3" & 4" Concentric Vent Kits Part Identification

Concentric Vent Size	(A) in inches	(B) in inches
4 in	4 1/2 in	6 5/8 in
3 in	3 in	4 1/2 in



**Vertical Installation continued-**

2. Determine the best location for the termination kit.
3. Cut the recommended 6 5/8 in (16.9 cm) diameter hole for 4 in (10.2 cm) vent termination or 4 1/2 in (11.5 cm) for 3 in (7.6 cm) vent termination.
4. Partially assemble vent kit by performing the following:
  - a. Cement concentric Y fitting to larger diameter pipe (see Figure 21).
  - b. Cement rain cap to smaller diameter pipe (see Figure 22).



**Figure 22 - Rain Cap to Small Vent Pipe Assembly**

5. Install concentric Y fitting and pipe assembly through the structure's hole and field-supplied roof boot/flashing. Do **NOT** allow insulation or other materials to accumulate inside pipe assembly when installing through the hole.
6. Secure assembly to roof structure as shown in Figure 23 using field-supplied metal strapping or equivalent support material.

**NOTICE**

Ensure termination height is above the roof surface or anticipated snowfall (see Figure 23).

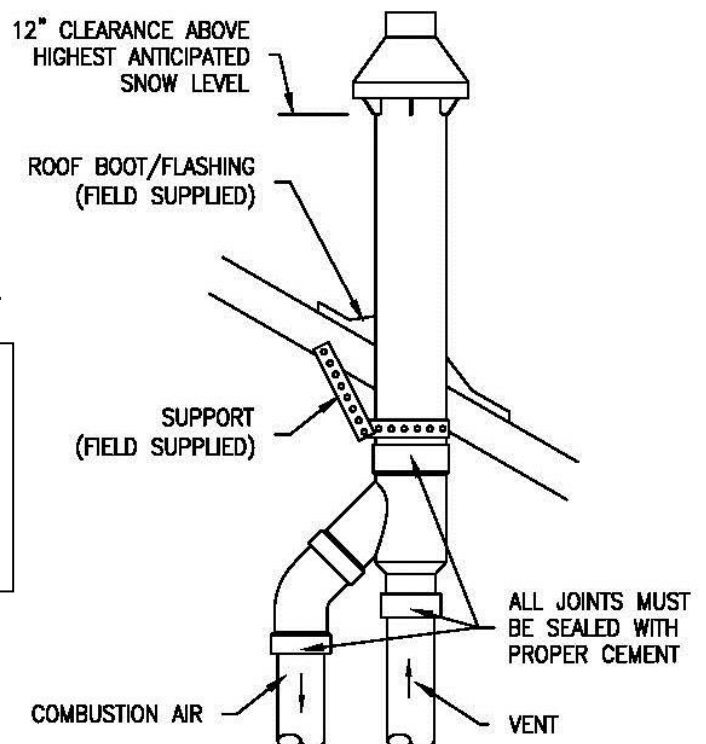
If assembly is too short to meet height requirements, the two pipes supplied in the kit may be replaced by using the same diameter pipe. **DO NOT** extend the overall dimension by more than 60 in (1.52 m).

7. Install rain cap and small diameter pipe assembly in roof penetration assembly. Ensure small diameter pipe is cemented and bottomed in concentric Y fitting.
8. Cement heater combustion-air and vent pipes to concentric Y fitting assembly (Figure 21). See Figure 23 for proper pipe attachment.
9. Operate heater through one cycle to ensure combustion air and vent pipes are properly connected and sealed to concentric vent termination connections.

**IMPORTANT**

When using the 3 inch concentric vent terminal, the maximum combined vent length is reduced by 30 ft (100 ft combined 3 inch venting + 3 inch concentric terminal). When using the 4 inch concentric vent terminal, there is no reduction in vent length (200 ft combined 4 inch venting + 4 inch concentric terminal).

**Figure 23 - Concentric Vent Roof Top Attachment**



## Horizontal Installation

1. Become familiar with the approved coaxial vent kits from IPEX, as shown in Table 4 and Figures 20 through 22.
2. Determine the best location for the termination kit.

### NOTICE

Position termination where vent vapors will <b>NOT</b> damage plants/shrubs or air conditioning equipment.
Position termination where vent vapors will <b>NOT</b> be adversely affected by wind condition.
Position termination where it will <b>NOT</b> be damaged or be subjected to foreign objects.
Position termination where vapors will <b>NOT</b> be objectionable.

3. Cut the recommended 6 5/8 in (16.9 cm) diameter hole for 4 in (10.2 cm) vent termination or 4 1/2 in (11.5 cm) for 3 in (7.6 cm) vent termination.
4. Partially assemble vent kit.
  - a. Cement concentric Y fitting to larger diameter kit pipe (see Figure 21).
  - b. Cement rain cap to smaller diameter kit pipe (see Figure 22).
5. Install concentric Y fitting and pipe assembly through the structure's hole and field-supplied roof boot/flashing. Do **NOT** allow insulation or other materials to accumulate inside pipe assembly when installing through the hole.
6. Install rain cap and small diameter pipe assembly in concentric Y fitting and large pipe assembly. Ensure small diameter pipe is cemented and bottomed in concentric Y fitting.
7. Secure assembly to structure as shown in Figure 23. Ensure clearances as shown in Figure 24.
8. Cement heater combustion-air and vent pipes to concentric Y fitting termination assembly. See Figure 24 for proper pipe attachment.
9. Operate heater through one cycle to ensure combustion-air and vent pipes are properly connected and sealed to concentric vent termination connections.

### IMPORTANT

When using the 3 inch concentric vent terminal, the maximum combined vent length is reduced by 30 ft (100 ft combined 3 inch venting + 3 inch concentric terminal). When using the 4 inch concentric vent terminal, there is NO reduction in vent length (200 ft combined 4 inch venting + 4 inch concentric terminal).

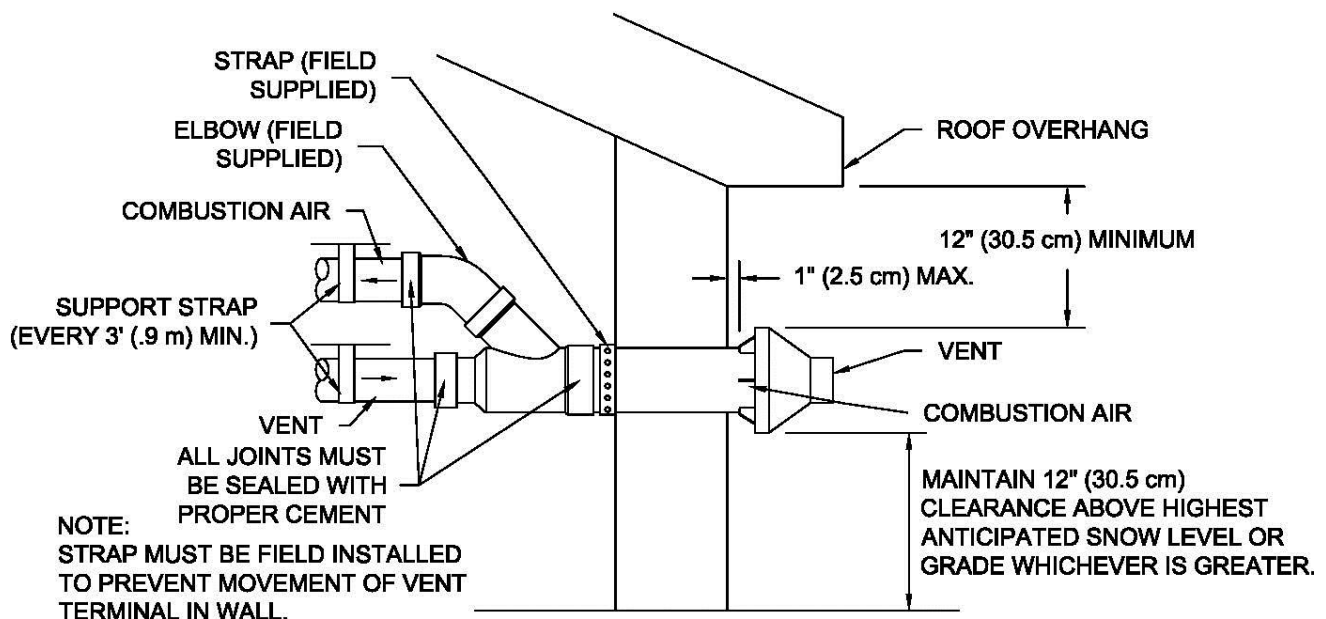


Figure 24 - Concentric Vent Side Wall Attachment

## Low Profile Side Wall Termination Kit

The IPEX Low Profile side wall termination kits are fully certified for use with IPEX product only. IPEX System 636 PVC Low Profile vent kits are made from certified compound and IPEX System 1738 PVC Low Profile vent kits are made from a UL1738 certified PVC compound. Both are rated to a maximum temperature of 149°F (65°C).

The vent termination **must** maintain all termination clearances and be installed in accordance with local building codes and/or The National Fuel Gas Code ANSI Z223.1 (Latest Edition) or CGA/CAN B149 Installation Code (see Figure 25).

Each kit contains: 1 Base (two holes), 1 Cap (one hole), 8 Stainless Steel Screws, and 4 Plastic Anchors.

**Table 5 – Approved IPEX Low Profile Terminals**

Description	Pipe O.D.	Hole Spacing (ctr to ctr)	IPEX System (1738 or 636)	IPEX Part Number
3" Low Profile	3.5"	5.6"	636	196985
3" Low Profile	3.5"	5.6"	1738	397985
4" Low Profile	4.5"	5.6"	636	196986
4" Low Profile	4.5"	5.6"	1738	397086

### **WARNING**

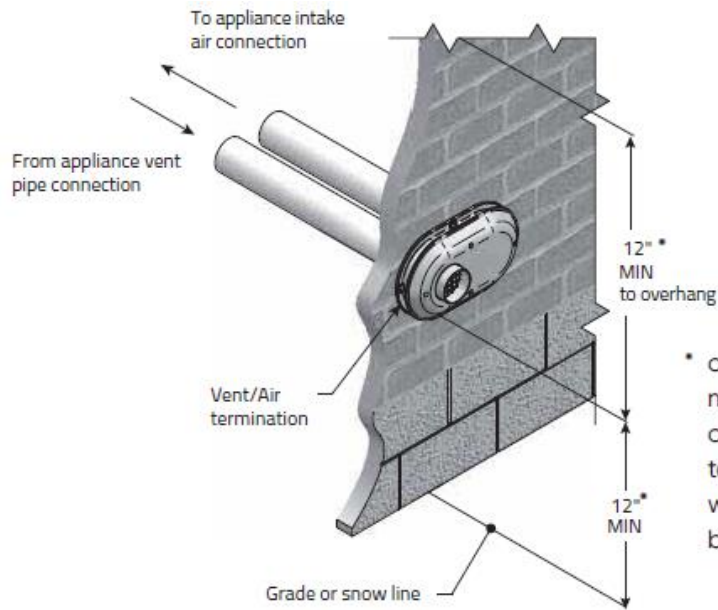
When locating the penetration of the vent and air pipe, ensure the termination is properly oriented as shown in Figure 26 and ensure that it maintains minimum clearance requirements as shown in Figure 25. For multiple vent terminations, ensure that a minimum clearance of 12 in (30 cm) is maintained between edge of air inlet and adjacent vent outlet and that all vent pipes and air inlets terminate at the same height to avoid the recirculation of flue gases and the possibility of causing severe personal injury, death, or substantial property damage (see Figure 28).

### **CAUTION**

When installing the vent termination in a vertical configuration, ensure the vent piping is located above the air inlet piping. This will avoid the risk of flue gas products recirculating into the air inlet and building.

## Installation Procedure

1. Once the proper location has been determined, cut 2 holes in the wall large enough to accommodate the pipe. Pipe diameters and distance between hole centers can be found in Table 5.
2. Slide both the intake and vent pipe through the holes. Solvent weld both pipes to the base of the vent termination kit (see Figure 25).
3. To fasten the base to the wall, use the supplied screws and anchors. A 3/16 in (5 mm) diameter, 1/16-3/16 in (2-5 mm) deep hole will need to be drilled for the anchors. Locate the anchor hole by using the base as a template and then drill the required holes.
4. Screw the cap to the base using the supplied screws.
5. Once the vent termination and pipes are secured, the wall penetrations will need to be sealed from the interior using a PVC compatible material.

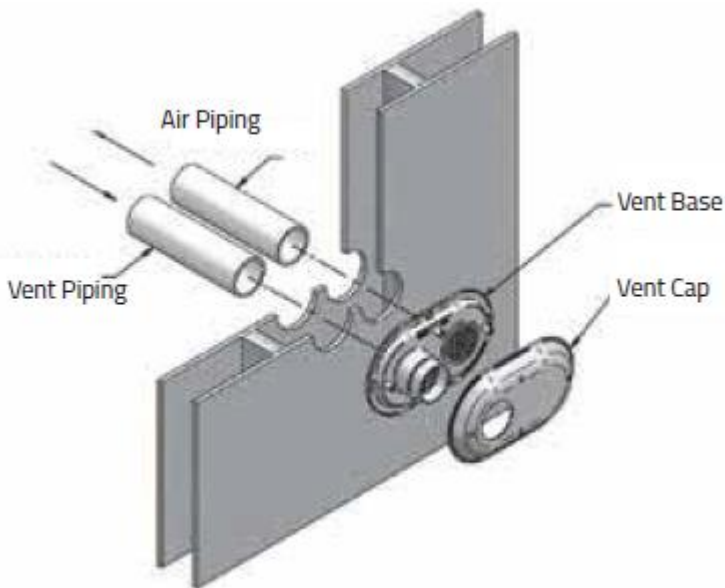
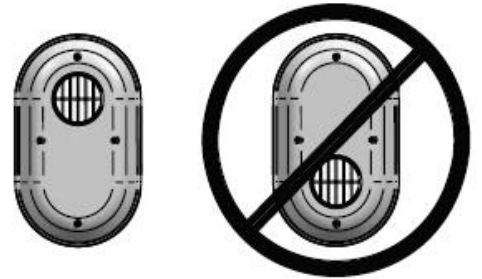


**Figure 25 – Typical Side Wall Termination**

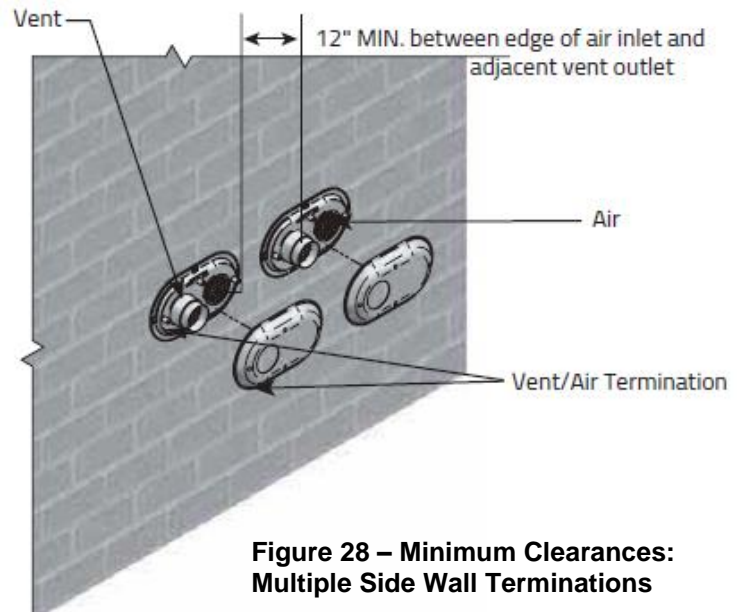
\* confirm minimum clearance for termination with local building code.



**Figure 26 – Approved Installation Orientation**



**Figure 27 – Side Wall Termination Assembly**



**Figure 28 – Minimum Clearances: Multiple Side Wall Terminations**

## Vent Pipe Preparation



**DO NOT** attempt to start this water heater until vent pipe solvent fumes completely clear from the room and inside the vent piping.

### Vent Pipe Preparation and Joining

Most failures in vent systems result from improper preparation and joining of pipe and fittings. The guidelines below must be followed when installing the venting system. If you have any questions about the application or installation of the venting system, contact the vent pipe manufacturer, supplier, or your plumbing professional.

- 1) Specific cleaners, solvents, primers, and cements are available for PVC, CPVC, and ABS pipe. Be sure these materials match the type of pipe to be installed. The vent pipe manufacturers joining instructions must be followed in all cases. Never use all-purpose cements, commercial glues and adhesives or ABS cement to join PVC or CPVC pipe and fittings. Refer to the table at the beginning of the Venting section for approved primers and cements.
  - a) **CLEANERS, SOLVENTS, PRIMERS AND CEMENTS ARE FLAMMABLE. Do NOT store or use these materials near heat or open flame, or in the vicinity of other appliances.**
- 2) Use proper cutting, deburring, and applicator tools to ensure proper preparation and joining of pipe and fittings.
  - a) Cutting Tools
    - i) A square cut must be achieved with a miter box saw or pipe cutter to ensure a proper mating with the female. If a pipe cutter is used, the burr created at the outer edge of the pipe must be removed.
  - b) Deburring Tools
    - i) A file, knife, or plastic deburring tool can be used to remove burrs. Burrs must be removed from the inside and outside edges of the pipe to ensure a proper seal.
  - c) Applicator Tools
    - i) A natural bristle paintbrush or roller may be used to apply cement. Prompt application of the cement is important due its fast drying properties.
- 3) Inspection, Cleaning, Priming and Cementing
  - a) Inspect the pipe inside and out for dirt, dust, moisture, grease, etc. Check pipe and fittings for splits or cracks and replace if found.
  - b) Clean pipe and fittings are imperative for proper joining. Following cutting and deburring, wipe away any foreign material with a clean dry rag. If wiping fails to thoroughly clean surfaces, chemical cleaning is necessary.
  - c) Primer must be applied to the pipe surface and fitting socket with a natural bristle brush. This serves to soften and prepare the pipe for cementing.
  - d) Cementing must be done quickly to avoid over-drying before joining.
    - i) Apply one coat to the outside end of the pipe at a width slightly greater than the depth of the socket.
    - ii) Apply a coat around the inside of the fitting socket.
    - iii) Apply a second coat around the end of the pipe.
- 4) Joining
  - a) Joints should be made immediately after cement is applied.
  - b) After fully inserting pipe into fitting socket, hold joint together for about 15 to 20 seconds.
  - c) Remove excess cement from around pipe and fitting with a clean rag.
  - d) Cement drying times may vary. Be sure to allow for the recommended drying time before disturbing joints.

For more specific and detailed information about the above, contact the vent pipe manufacturer, supplier, or a certified professional.

## SECTION VII: GAS CONNECTIONS

The gas supply lines must meet all requirements of the National Fuel Gas Code ANSI Z223.1 (Latest Edition), or in Canada CAN/CGA B149.1 Natural Gas Installation Code (Latest Edition) or CAN/CGA B149.2 Propane Installation Code (Latest Edition).

1. Connect this water heater only to the type of gas as shown on the rating plate. Use clean black iron pipe or equivalent material approved by local codes and ordinances (dirt and scale from the pipe can enter the gas valve and cause it to malfunction). The inlet gas line must have a minimum length of 3 in (7.6 cm) drip leg (sediment trap) installed as close to the water heater's gas valve as possible. A ground joint union must be installed as close to the water heater as possible in the gas supply line feeding the water heater to permit servicing of the water heater. Compounds used on the threaded joints of the gas piping must be resistant to the action of liquefied petroleum gases/propane gas. **DO NOT** apply pipe dope to the gas valve inlet and make certain that no pipe dope has become lodged in the inlet screen of the gas valve. Extreme care must be taken to ensure no pipe dope enters the gas valve. Avoid excessive torque when tightening the gas supply line to the gas valve. Excessive torque may result in cracking of the gas valve housing and could create a gas leak. The suggested maximum torque is 31.5 ft. lbs. (4.4 kg-m).

### NOTICE

The manufacturer of this water heater will **NOT** be liable for any damage or injury caused as a result of a cracked gas inlet as a result of excessive torque.

2. This water heater and its gas connection must be leak tested before placing the water heater in operation. Check for gas leaks with a soap and water solution and a brush or a commercial leak detector fluid.

### WARNING

**NEVER USE A MATCH OR OPEN FLAME FOR TESTING.**

3. While checking for leaks care must be taken to prevent solution from contacting the electrical connections at the control. If electrical connections at the control become wet, they must be thoroughly dried before attempting to operate the water heater.

### WARNING

The water heater is **NOT** intended for operation at higher than 14 inch water column (½ psi) supply gas pressure. Higher gas supply pressures require supplemental reducing service regulation. Exposure to higher gas supply pressure may cause damage to the gas controls, which could result in fire or explosion. If overpressure has occurred, such as through improper testing of gas lines or emergency malfunction of the supply system, the gas valve must be checked for safe operation. Make sure that the outside vents on the supply regulators and the safety vent valves are protected against blockage. These are parts of the gas supply system, **NOT** the water heater.

### CAUTION

The water heater and individual shutoff valve **must** be disconnected from the gas supply piping system during any pressure testing of the system at test pressures in excess of ½ psi (3.5 kPa). The water heater must be isolated from the gas supply piping system by closing its manual shutoff valve during any pressure testing of the gas supply system at test pressures equal to or less than ½ psi (3.5 kPa). The supply line must be capped when **not** connected to the water heater.

If copper supply lines are used, they **must** be internally tinned and certified for gas service.

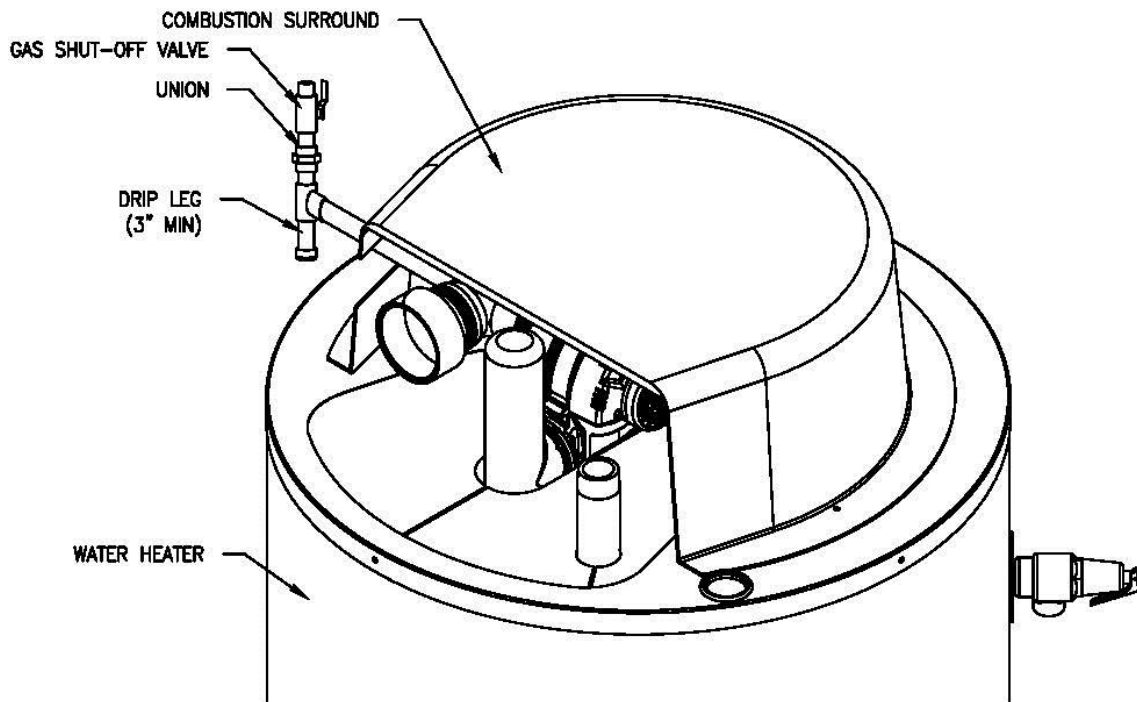


Figure 29 – Drip Leg 120T400/500

### Gas Meter Size – Natural Gases Only

Be sure that the gas meter has sufficient capacity to supply the full rated gas input of the water heater as well as the requirements of all other gas fired equipment supplied by the meter. If the gas meter is too small, ask the gas company to install a larger meter with adequate capacity.

### Gas Pressure Regulation

Main line gas pressure to the water heater should be between a maximum 14.0 inch W.C. and a minimum supply pressure as shown on the rating plate. The inlet gas pressure must **NOT** exceed the maximum value. In some installations, a regulator sized for the input rating of the water heater will need to be installed. Install in accordance with the manufacturer for the regulator.

**BEFORE PLACING THE WATER HEATER IN OPERATION, CHECK FOR GAS LEAKAGE. USE SOAP AND WATER SOLUTION OR OTHER MATERIAL ACCEPTABLE FOR THE PURPOSE OF LOCATING GAS LEAKS.**

## ⚠ WARNING

**Do NOT use matches, candles, flames, or other sources of ignition for this purpose.**

# SECTION VIII: ELECTRICAL CONNECTIONS

## ⚠ WARNING

Turn OFF or disconnect the electrical power supply to the water heater before servicing. Label all wires prior to disconnection when servicing controls. Wiring errors can cause improper and dangerous operation. Verify proper operation after servicing.

All electrical wiring must be installed and grounded in accordance with local codes, or in the absence of local codes, the National Electrical Code, ANSI/NFPA 70 and/or CSA C22.2 Electrical Code.

The water heater **must be** wired to a 120 VAC, 60 Hz, 15A power supply. The water heater **must be** wired on a separate circuit and breaker. If a flexible line cord and plug is permitted by local code, then provide a three wire grounding type receptacle within reach of the line cord provided on the control box. **Do NOT** plug the line cord into a receptacle that can have the power supply interrupted by a switch that is used to control lights or another appliance.

If wiring in conduit is required, cut the line cord close to the control board and make the appropriate wiring connections. Install an electrical conduit connector on the outside jacket of the water heater. Refer to the wiring diagram for the correct connections to each wire lead.

## ⚠ CAUTION

This water heater **must be** wired on a separate circuit. Failure to wire on a separate circuit may cause improper operation or failure of the electrical components of the water heater.

**DO NOT** energize the electric circuit before the water heater tank is filled with water.

This controller is polarity sensitive. If the HOT and NEUTRAL supply voltage is reversed, the controller will **NOT** sense flame and the water heater will **NOT** operate. Verify polarity before connecting the water heater.

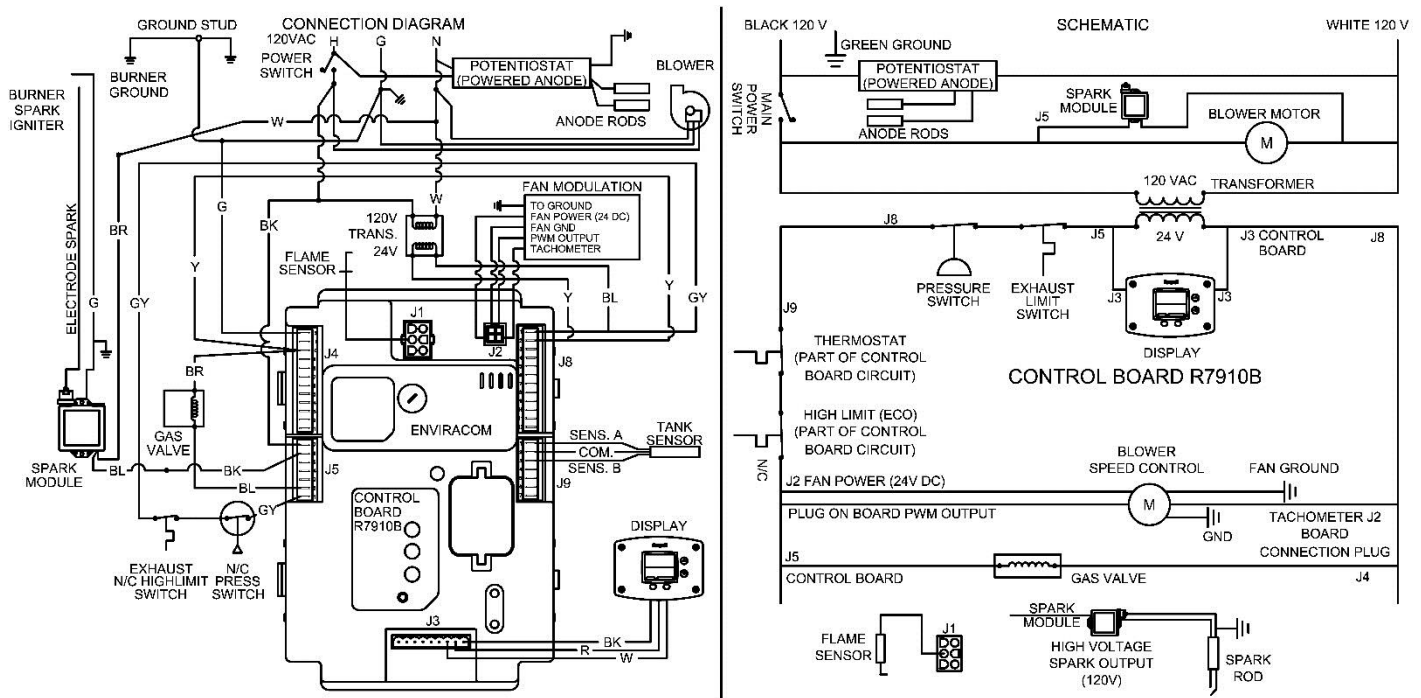


Figure 30 – Wiring Diagram and Schematic



## Building Management System (BMS)

The 120T can be equipped with a gateway kit that will facilitate a Building Management System (BMS) connection to Modbus or Bacnet®. This kit is sold separately and is not factory installed. A full installation, operation, and troubleshooting manual is provided with the gateway kit.

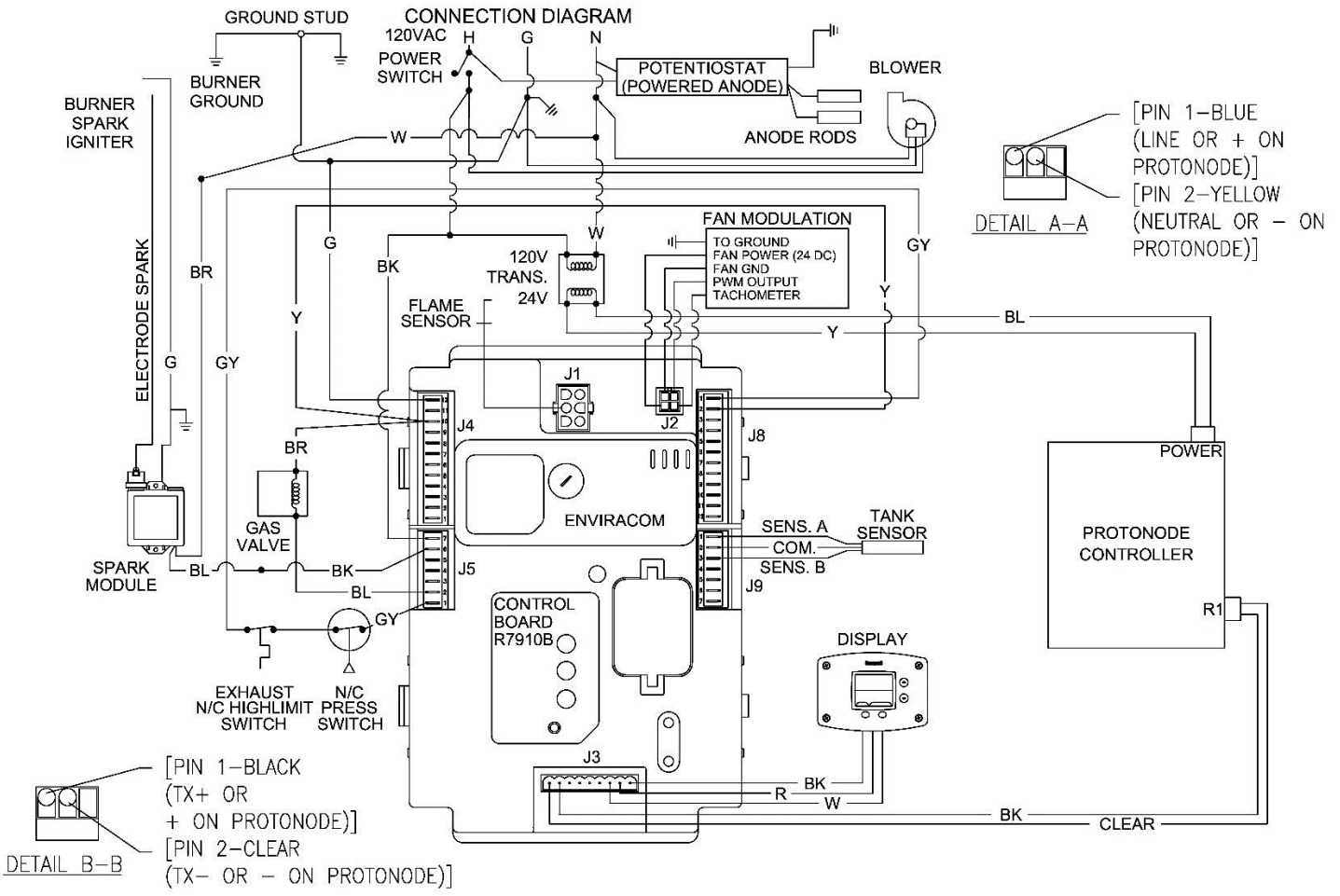
### CAUTION

Before beginning any Troubleshooting operations listed below, please note that the gateway kit and BMS may need to be disconnected from the heater. Please ensure this has been completed before proceeding with any troubleshooting operation that may be impacted by settings in the BMS.

## BMS Mapping

Map Descriptor Name	Modbus Register	Read/Write	BACnet Object ID	Note
Demand source	00006	Read	001	Current demand source: 0= Unknown 1= No source demand 2= CH 3= DHW 4= Lead Lag slave 5= Lead Lag master 6= CH frost protection 7= DHW frost protection 8= No demand due to burner switch (register 199) turned off 9= DHW storage 10= Reserved 11= Warm weather shutdown 12= Hot standby
Firing rate	00008	Read	002	Actual firing rate (% or RPM)
Fan speed	00009	Read	003	RPM
Flame signal	00010	Read	004	0.01V or 0.01µA precision (0.00-50.00V)
Tank temperature sensor	00012	Read	005	-40°-130° (0.1°C precision)
Appliance setpoint	00017	Read	006	-40°-130° (0.1°C precision)
Burner status	00032	Read	007	0= Disabled 1= Locked out 2-3= Reserved 4= Anti-short cycle 5= Unconfigured safety data 6-33= Reserved 34= Standby Hold 35= Standby Delay
Lockout code	00034	Read	008	0= No lockout 1-4096
Appliance status	00080	Read	009	0= Unknown 1= Disabled 2= Normal 3= Suspended
DHW priority count	00082	Read	010	Countdown of time when DHW has priority over CH (secs). Applicable when DHW priority time is enabled.
Burner run time	00130/00131	Read	011	Hours
Controller cycle count	00142/00145	Read	012	0-999,999
Controller run time	00144/00145	Read	013	Hours
Alarm reason	0035	Read	014	0= None 1= Lockout 2= Alert 3= Other
DHW setpoint	0453	Read/Write	015	40°-130° (0.1°C precision)

# BMS Wiring Diagram



## SECTION IX: OPERATING INSTRUCTIONS

### WARNING

Water heaters are heat-producing appliances. To avoid damage or injury there must be no materials stored against the water heater or direct vent system, and proper care must be taken to avoid unnecessary contact (especially by children) with the water heater and direct vent system. **UNDER NO CIRCUMSTANCES SHOULD FLAMMABLE MATERIALS, SUCH AS GASOLINE OR PAINT THINNER BE USED OR STORED IN THE VICINITY OF THIS WATER HEATER OR IN ANY LOCATION FROM WHICH FUMES COULD REACH THE WATER HEATER.**

Installation or service of this water heater requires ability equivalent to that of a licensed tradesman in the field involved. Plumbing, air supply, venting, gas supply, and electrical work are required.

Light the unit in accordance with the operating instructions label attached to the water heater.

Under **NO** circumstances should the input rate exceed the input rate shown on the water heater rating plate. Over-firing could result in damage or sooting of the water heater.

If the unit is exposed to the following, **DO NOT** operate water heater until all corrective steps have been made by a factory authorized independent service contractor or qualified service professional.

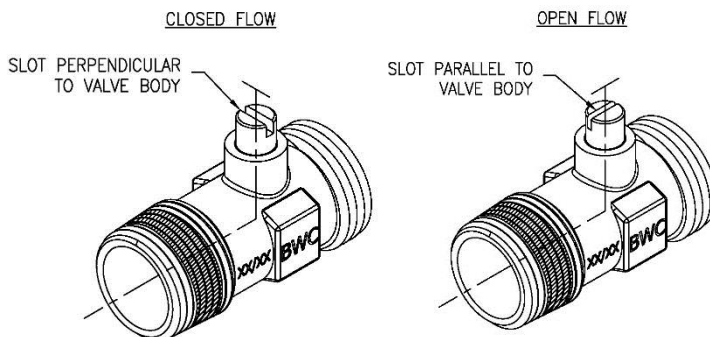
- |   |                    |
|---|--------------------|
| 1. Flooding to or above the level of the burner or controls | 2. External firing |
| 3. External firing  | 4. Damage          |
| 5. Firing without water                                     | 6. Sooting         |

**NEVER OPERATE THE WATER HEATER WITHOUT FIRST BEING CERTAIN IT IS FILLED WITH WATER AND THAT A TEMPERATURE AND PRESSURE RELIEF VALVE IS INSTALLED IN THE RELIEF VALVE OPENING OF THE WATER HEATER.**

### General Instructions

#### To Fill the Water Heater

1. Close the water heater drain valve. This water heater utilizes a ball valve; when closing the valve, the stem will spin indefinitely. Confirm it is closed by ensuring the slot on the stem is perpendicular to the valve body. If alternative water connections are provided but not used, make certain they are plugged (i.e. space heating & alternate top connections).
2. Open the cold water supply shut-off valve.
3. Open several hot water faucets to allow air to escape from the system.
4. When a steady stream of water flows from the faucets, the water heater is filled. Close the faucets and check for water leaks at the water heater drain valve, combination temperature and pressure relief valve and the hot and cold water connections.



#### Sequence of Operation

1. Thermostat starts with heating cycle.
2. Blower turns ON.
3. Blower pre-purge at reduced speed.
4. The spark generator turns on and a spark is produced at the spark rod. The fuel air mixture is lit.
5. Flame signal confirmed with main burner ON.
6. Blower remains at reduced speed for a short period to stabilize flame.
7. Blower modulates depending on heater demand.
8. Thermostat becomes satisfied.
9. Gas valve closes, then the main burner turns OFF.
10. Blower post purges, then turns OFF.

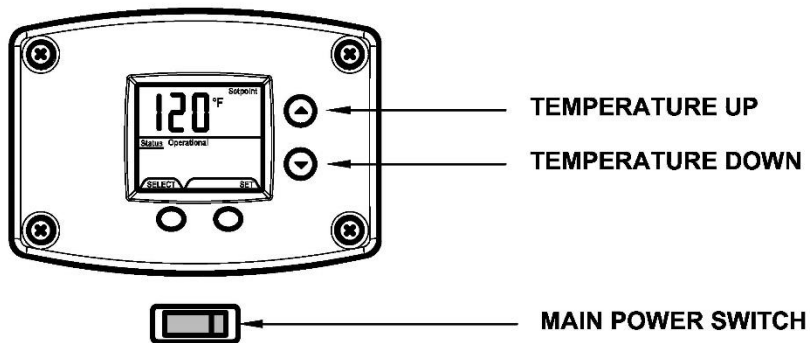
**FOR YOUR SAFETY READ BEFORE LIGHTING**

**WARNING:** If you do not follow these instructions exactly, a fire or explosion may result causing property damage, personal injury or loss of life.

- A. This appliance does not have a pilot. It is equipped with an ignition device which automatically lights the burner. Do not try to light the burner by hand.
- B. **BEFORE OPERATING** smell all around the appliance for gas. Be sure to smell next to the floor because some gas is heavier than air and will settle on the floor.  
**WHAT TO DO IF YOU SMELL GAS:**
  - Do not try to light any appliance.
  - Do not touch any electric switch; do not use any phone in your building.
  - Immediately call your gas supplier from a neighbor's phone. Follow the gas supplier's instructions.
  - If you cannot reach your gas supplier, call the fire department.
- C. Turn off main power to the water heater.
- D. Do not use this appliance if any part has been under water. Immediately call a qualified service technician to inspect the appliance and to replace any part of the control system and any gas control which has been under water.

**LIGHTING INSTRUCTIONS**

1. **STOP!** read the safety information above on this label.
2. Set the thermostat to lowest setting.
3. Turn off all electrical power to the appliance.
4. This appliance does not have a pilot. It is equipped with an ignition device which automatically lights the burner. Do not try to light the burner by hand.
5. Turn off the main power switch.
6. Wait (5) minutes to clear out any gas. If you then smell gas, **STOP!** Follow "B" in the safety information above on this label if you don't smell gas, go to next step.
7. Turn on main power switch.
8. Set the thermostat to desired setting.



**TO TURN OFF GAS TO APPLIANCE**

1. Set the thermostat to lowest setting.
2. Turn off the main power switch.

Figure 31 – Lighting Instruction Label

## Temperature Adjustment

Table 6 – Approximate Time/Temperature Scald Chart

APPROXIMATE TIME/TEMPERATURE RELATIONSHIPS IN SCALDS	
120°F (49°C)	More than 5 minutes
125°F (52°C)	1½ to 2 minutes
130°F (54°C)	About 30 seconds
135°F (57°C)	About 10 seconds
140°F (60°C)	Less than 5 seconds
145°F (63°C)	Less than 3 seconds
150°F (66°C)	About 1½ seconds
155°F (68°C)	About 1 second

### DANGER

Hotter water increases the risk of scald injury. Scalding may occur within 5 seconds at a temperature setting of 140°F (60°C). To protect against hot water injury, install an ASSE approved mixing valve in the water system. This valve will reduce point of discharge temperature by mixing cold and hot water in branch water lines. A licensed plumbing professional or local plumbing authority should be consulted.

### CAUTION

This water heater, when set at a lower temperature setting, is **NOT** capable of producing hot water of sufficient temperature for sanitizing purposes.

This water heater is equipped with an energy cut out device to prevent overheating. Should overheating occur or the gas supply fails to shut off, turn OFF the control panel power switch to the appliance and call a qualified service agency.

### NOTICE

The lower the temperature setting, the greater the energy efficiency, both to heat the water and to maintain the storage temperature during standby periods. Lower water temperatures also extend tank life. Remember, no water heating system will provide exact temperatures at all times. Allow a few days of operation at this setting to determine the correct temperature setting consistent with the requirements for the installation.

The water heater temperature setting is adjusted by using the control display mounted to the water heater. The water heater thermostat is set at the lowest setpoint of 100°F (38°C) when shipped from the factory. The control display shows the temperature setpoint in degrees Fahrenheit (°F) or degrees Celsius (°C), and the status of the water heater (“Idle” or “Heating”). If the water heater is functioning normally, the display will also show “Operational.”

For energy efficient operation of your water heater, the suggested initial temperature setting is 120°F (49°C). During the winter season, or any cold period, you may desire a higher temperature setting to adjust for the colder incoming water. This adjustment, however, may cause additional condensation to form on the cooler tank surface. This does **NOT** mean the tank is leaking. During summer months, the warmer incoming water temperatures will benefit the performance of your water heater and reduce the amount of condensation developed.

Condensation does **NOT** mean your tank is leaking. Most reported tank leaks at installation are proven to be condensation. To avoid unnecessary inconvenience and expense, make sure the tank is leaking, and that it is not condensation, before calling an independent servicing contractor or qualified service professional.

If the water heater is to remain idle for 30 days or more or is subjected to freezing temperatures while shut off, the water heater and piping should be fully drained, and the drain valve should be left fully open. Refer to the “Draining the Water Heater” in this Installation and Operation Manual (page 52) for this procedure.

## ⚠ WARNING

Hydrogen gas can be produced in an operating water heater that has not had water drawn from the tank for a long period of time (generally two weeks or more). **HYDROGEN GAS IS EXTREMELY FLAMMABLE.** To prevent the possibility of injury under these conditions, we recommend a hot water faucet to be open for several minutes before you use any electrical appliance which is connected to the hot water system. If hydrogen is present, there will be an unusual sound such as air escaping through the pipes as hot water begins to flow. **DO NOT** smoke or have open flame near the faucet at the time it is open.

## ⚠ WARNING

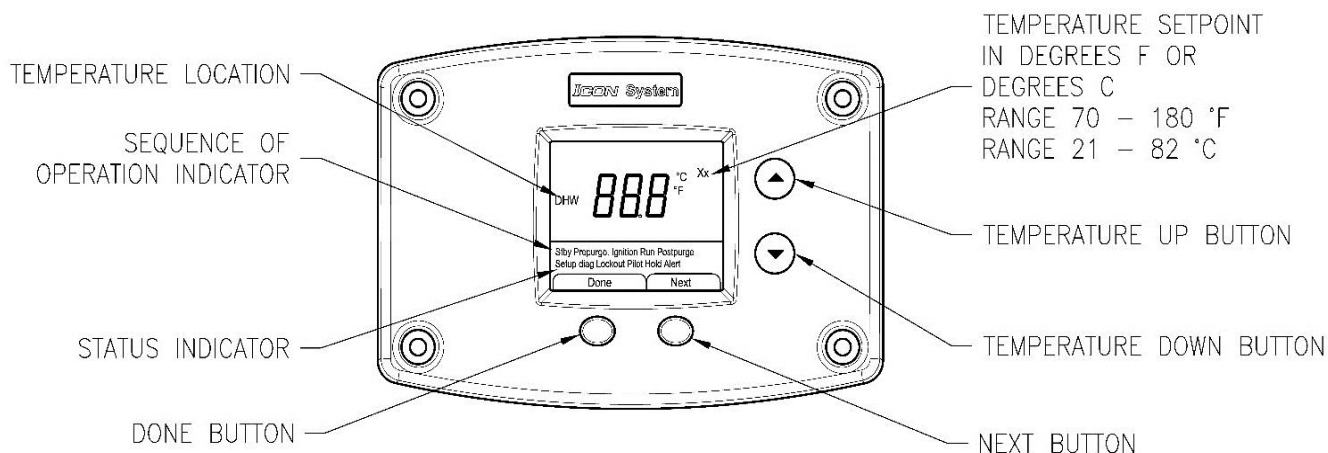
If the water heater display does not show "Operational" in the "Status" indicator, there may be an operating malfunction with the water heater. If this is the case, a numeric code will be displayed. Refer to the label next to the display for the definition of the error code and call your plumbing professional or service agent to service the water heater. **DO NOT** try to reset the water heater without having a qualified service person attempt to diagnose and correct the problem. If the display is blank or does not show an error code, make sure there is power to the water heater.

Setting the water temperature to the maximum set point can result in scalding hot water delivered to the faucets. It is highly recommended that the maximum setpoint be adjusted to the lowest temperature possible for the needs of the installation. See the following section to change the maximum setpoint limit (max setpoint). Make sure the water heater control display is not in a public area that can result in the temperature settings being improperly adjusted. See previous warning on scalds and an ASSE approved mixing valve.

## NOTICE

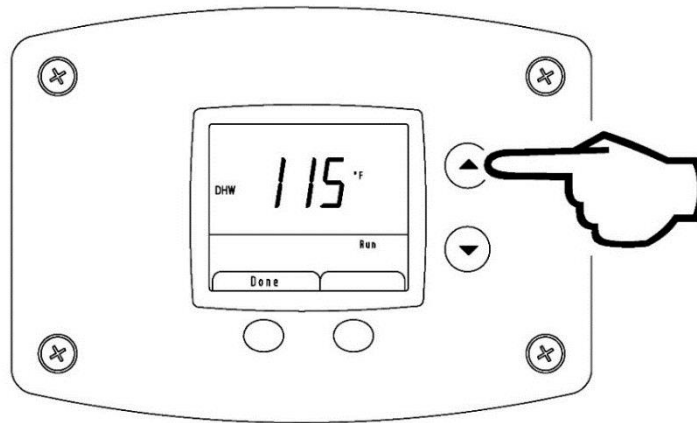
When the maximum setpoint is reached, the display will show "Max Setpoint" without the setpoint value. The maximum setting is equal to approximately 180°F (82°C). The default temperature setpoint from the factory is 100°F (38°C).

### Water Heater Display and Control Buttons

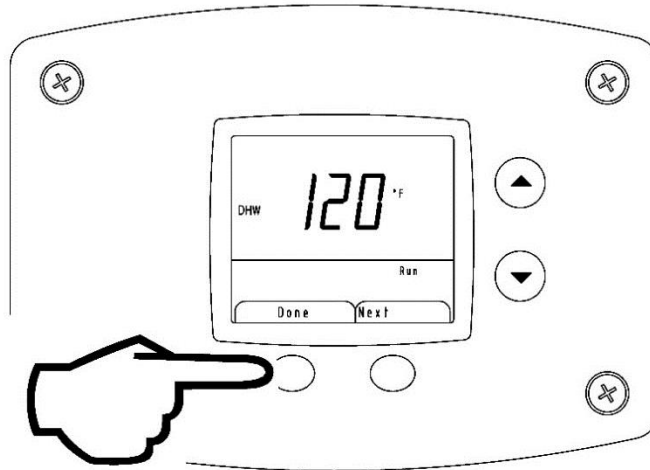


## To Increase Setpoint Temperature

**Step 1:** Press and hold “Temperature Up” button until desired setpoint temperature appears on the display.



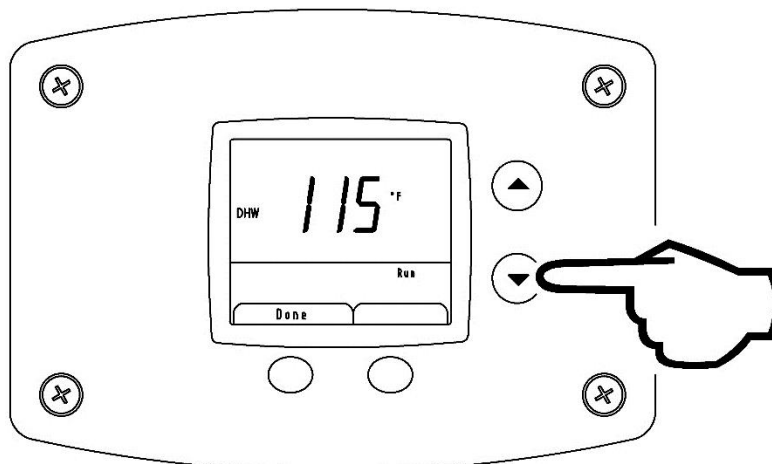
**Step 2:** Press “DONE” button for new setting to take effect immediately. If the “DONE” button is not pressed, the new temperature setting will take effect in approximately 10 seconds.



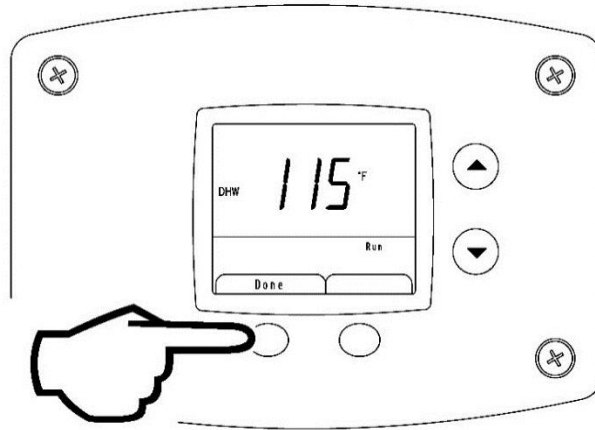
PRESS DONE BUTTON FOR SETTING TO  
TO TAKE EFFECT IMMEDIATELY

## To Decrease Temperature Setpoint:

**Step 1:** Press and hold “Temperature Down” button until desired setpoint temperature appears on the display.



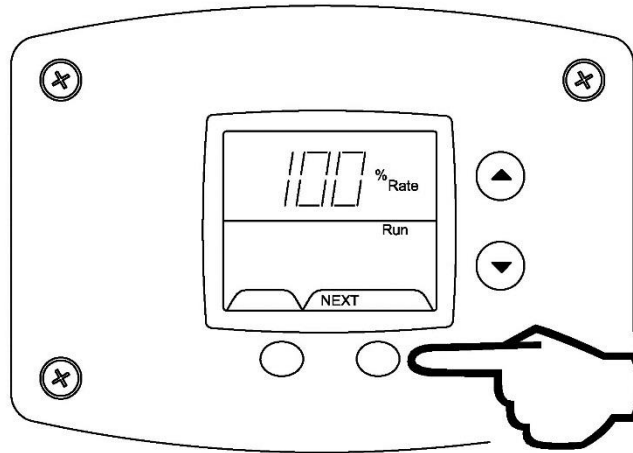
**Step 2:** Press “DONE” button for new setting to take effect immediately. If the “DONE” button is not pressed, the new temperature setting will take effect in approximately 10 seconds.



PRESS DONE FOR SETTING TO  
TO TAKE EFFECT IMMEDIATELY

### To View Combustion Rate

**Step 1.** Select Next while viewing DHW Setpoint in User Mode to access Rate screen. Rate will only be displayed while the burner is operating.



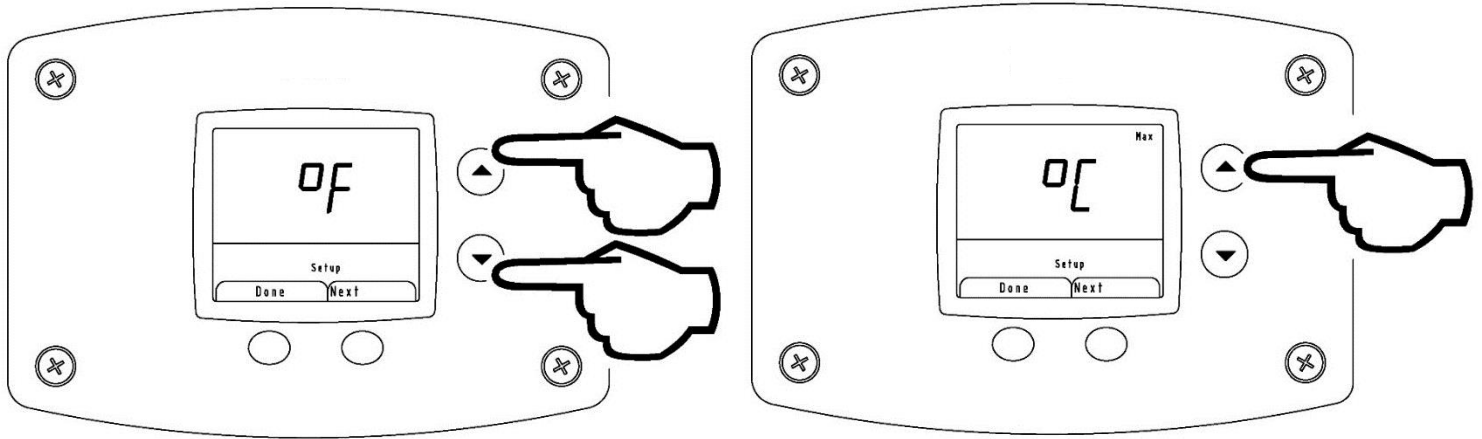
**Step 2.** Select Next to go back to the DHW Setpoint screen.



## To Change Temperature Format in Display from °F to °C or °C to °F

**Step 1.** Enter “Set-Up Mode” by pressing both UP/DOWN buttons together for 3 seconds.

**Step 2.** Use the arrows to select between °F and °C



**Step 3.** Press done to return to main screen or timeout/change will occur in one minute.

## Energy Cut Out (ECO)

An Energy Cut Out (ECO) is incorporated in the sensor and control board which will shut off all gas supply to the burner if the water heater temperature exceeds 207°F (97.2°C). Should the ECO function (open), the water temperature should be reduced to approximately 120°F (49°C) and a qualified service agent must be called to place the water heater in operation. The water heater must have the problem corrected by a qualified service agent before putting the water heater back in operation. It is recommended that all service work be performed by a qualified service agency.

### **WARNING**

Hydrogen gas can be produced in an operating water heater that has not had water drawn from the tank for a long period of time (generally two weeks or more). **HYDROGEN GAS IS EXTREMELY FLAMMABLE.** To prevent the possibility of injury under these conditions, we recommend the hot water faucet to be open for several minutes at the kitchen sink before you use any electrical appliance which is connected to the hot water system. If hydrogen is present, there will be an unusual sound such as air escaping through the pipes as hot water begins to flow. **DO NOT smoke or have open flame near the faucet at the time it is open.**

### **WARNING**

**DO NOT** run out of propane gas. Damage to the water heater may occur.

## SECTION X: MAINTENANCE

### **⚠ DANGER**

- DO NOT** attempt to repair gas valve.
- DO NOT** attempt to repair ignition module.
- DO NOT** attempt to repair venturi.
- DO NOT** attempt to repair thermostat board.
- DO NOT** attempt to repair transformer.
- DO NOT** attempt to repair pressure switch.

### **⚠ WARNING**

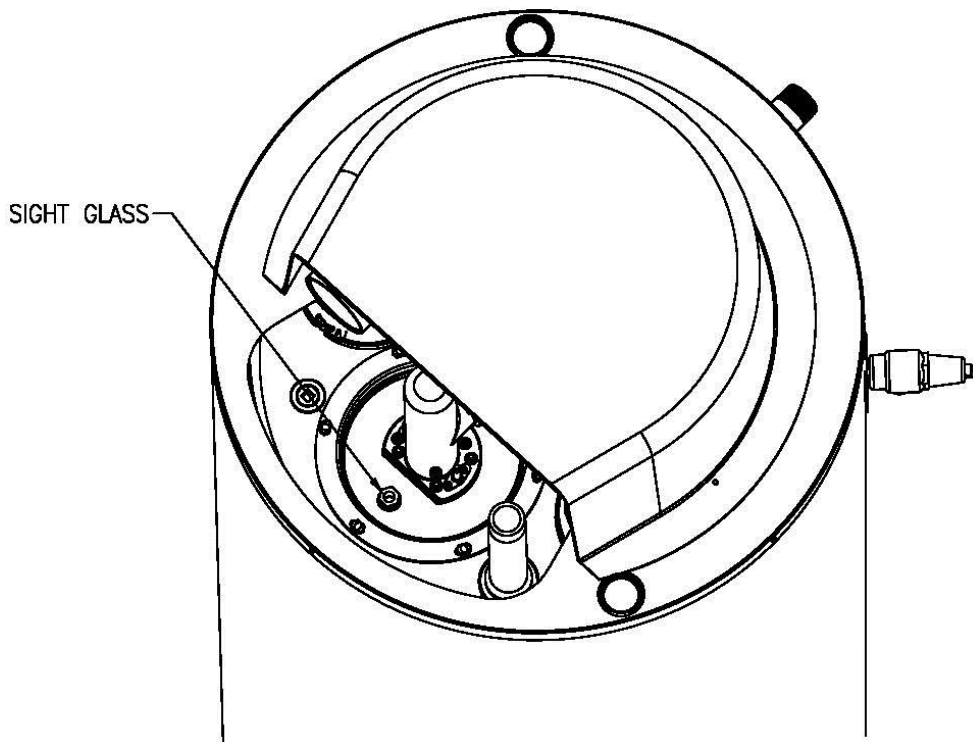
To avoid damage or injury, there must be no materials stored against the water heater or vent-air intake system, and proper care must be taken to avoid unnecessary contact (especially by children) with the water heater and vent-air intake system. **UNDER NO CIRCUMSTANCES SHOULD FLAMMABLE MATERIALS, SUCH AS GASOLINE OR PAINT THINNER BE USED OR STORED IN THE VICINITY OF THIS WATER HEATER, VENT-AIR INTAKE SYSTEM OR IN ANY LOCATION FROM WHICH FUMES COULD REACH THE WATER HEATER OR VENT-AIR INTAKE SYSTEM.**

#### **General**

Water heater maintenance includes monthly tank flushing and cleaning and removal of lime scale. The unit should be inspected and adjusted to maintain proper combustion. Refer to Table 7 – Suggested Maintenance Schedule. An annual inspection of the venting system should be made.

#### **Burner Flame Check**

At the time of installation and at monthly intervals, a visual check of the burner flames should be made to determine if they are burning properly. The main burner may be seen through the sight glass window on the front of the combustion insert mounting bracket (see Figure 32). The burner flames should be a blue flame near the burner surface in a uniform flame pattern. Occasional yellow or white streaks are normal.



**Figure 32 - Sight Glass Location**

## Maintenance Schedule

### WARNING

Water heaters are heat producing appliances. To avoid damage or injury there must be no materials stored against the water heater or vent-air intake system, and proper care must be taken to avoid unnecessary contact (especially by children) with the water heater and vent-air intake system. **UNDER NO CIRCUMSTANCES SHOULD FLAMMABLE MATERIALS, SUCH AS GASOLINE OR PAINT THINNER BE USED OR STORED IN THE VICINITY OF THIS WATER HEATER, VENT-AIR INTAKE SYSTEM OR IN ANY LOCATION FROM WHICH FUMES COULD REACH THE WATER HEATER OR VENT-AIR INTAKE SYSTEM.**

### IMPORTANT

The water heater should be inspected at a minimum annually by a qualified service technician for damaged components and/or joints not sealed. **DO NOT** operate this water heater if any part is found damaged or if any joint is found not sealed.

**Following are the instructions for performing some of the recommended maintenance. Unit inspection and adjustment should only be performed by a qualified technician.**

**Table 7 – Suggested Maintenance Schedule**

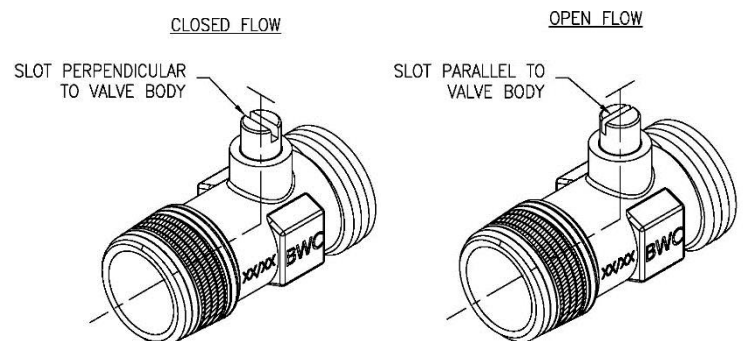
Service Interval	Component	Operation	Action
<b>1 Month:</b>	Tank	Sediment removal	Drain off several gallons of water.
	Condensate Line	Inspect & clean	Clear drainline and trap, verify proper pitch.
<b>1 Year:</b>	Powered Anode System	Check LED/inspect rods	1st year: check rods to determine service interval; check LED annually.
	Relief Valve	Function test	Operate lever, inspect for blockage or corrosion.
	Vent & Air Intake System	Inspect	Inspect joint seals/vent supports; clean air filter accessory kit if used.
	Vent Terminals	Free of blockage & debris	Clear intake and exhaust terminals, clean terminal screens.
	Combustion System	Inspect & clean	Clean flame sensor, igniter, & inspect burner.

### Flushing Water Heater

1. Turn OFF the water heater electrical disconnect switch.
2. Open the drain valve and allow water to flow until it runs clean.
3. Close the drain valve when finished flushing.
4. Turn ON the water heater electrical disconnect switch.

### Filling the Water Heater

1. Close the water heater drain valve. This water heater utilizes a ball valve; when closing the valve, the stem will spin indefinitely. Confirm it is closed by ensuring the slot on the stem is perpendicular to the valve body. If alternative water connections are provided but not used, make certain they are plugged (i.e. space heating & alternate top connections).
2. Open the cold water supply shut-off valve.
3. Open several hot water faucets to allow air to escape from the system.
4. When a steady stream of water flows from the faucets, the water heater is filled. Close the faucets and check for water leaks at the water heater drain valve, combination temperature and pressure relief valve and the hot and cold water connections.



## Draining the Water Heater

The water heater must be drained if it is to be shut down and exposed to freezing temperatures. Maintenance and service procedures may also require draining the water heater.

1. Turn OFF the water heater electrical disconnect switch.
2. Connect a hose to the drain valve.
3. Locate the hose discharge in an area where hot water will not cause any damage or injury.
4. Close the cold water inlet valve to the water heater.
5. Open a nearby hot water faucet to vent the system.
6. Open the heater drain valve.
7. If the water heater is being drained for an extended shutdown, it is suggested the drain valve be left open during this period.

## Sediment and Lime Scale Removal

Waterborne impurities consist of the particles of soil and sand, which settle out and form a layer of sediment on the bottom of the tank. The amount of calcium carbonate (lime) released from water is in direct proportion to water temperature and usage. The higher the water temperature or water usage, the more lime deposits are dropped out of the water. This is lime scale, which forms in pipes, water heaters, and on cooking utensils. Lime accumulation not only reduces the life of the equipment but also reduces efficiency of the water heater and increases fuel consumption.

The usage of water softening equipment greatly reduces the hardness of the water. However, this equipment does not always remove all of the hardness (lime). For this reason, it is recommended that a regular schedule of deliming be maintained.

The depth of the buildup should be measured periodically. Water heaters will have about 3 in (7.6 cm) of lime buildup when the level of lime has reached the bottom of the cleanout opening or about 1 in (2.5 cm) of lime buildup if it has reached the drain valve opening. A schedule for deliming should be set up, based on the amount of time it would take for a 1/2 in (1.3 cm) buildup of lime.

Example: Initial inspection shows 1/2 in (1.3 cm) of lime accumulation. Therefore, the water heater should be delimed once a year.

## To Remove Sediment and Lime Scale

1. Drain the water heater. Refer to 'Draining the Water' instructions in this section.
2. Remove the outer cover plate from lower side of water heater jacket.
3. Remove the cover and gasket from cleanout opening.
4. Remove lime, scale, or sediment using care not to damage the glass-lining.
5. Inspect cleanout plate gasket. Replace gasket if necessary (contact local distributor for correct part number).
6. Install gasket and cleanout plate. Be sure to draw plate up tight by tightening screws securely.
7. Close the drain valve. Open a hot water fixture to allow air to escape. Open the cold water supply to water heater and allow the tank to fill. Follow the lighting instructions.
8. Check for water leakage.
9. Install the outer jacket cover plate.

## Drain Valve and Tank Access Panel

The water heaters are equipped with a 3/4 in (2 cm) drain valve.

An access panel covers the cleanout opening in the tank, which is sealed by a gasket and cover.

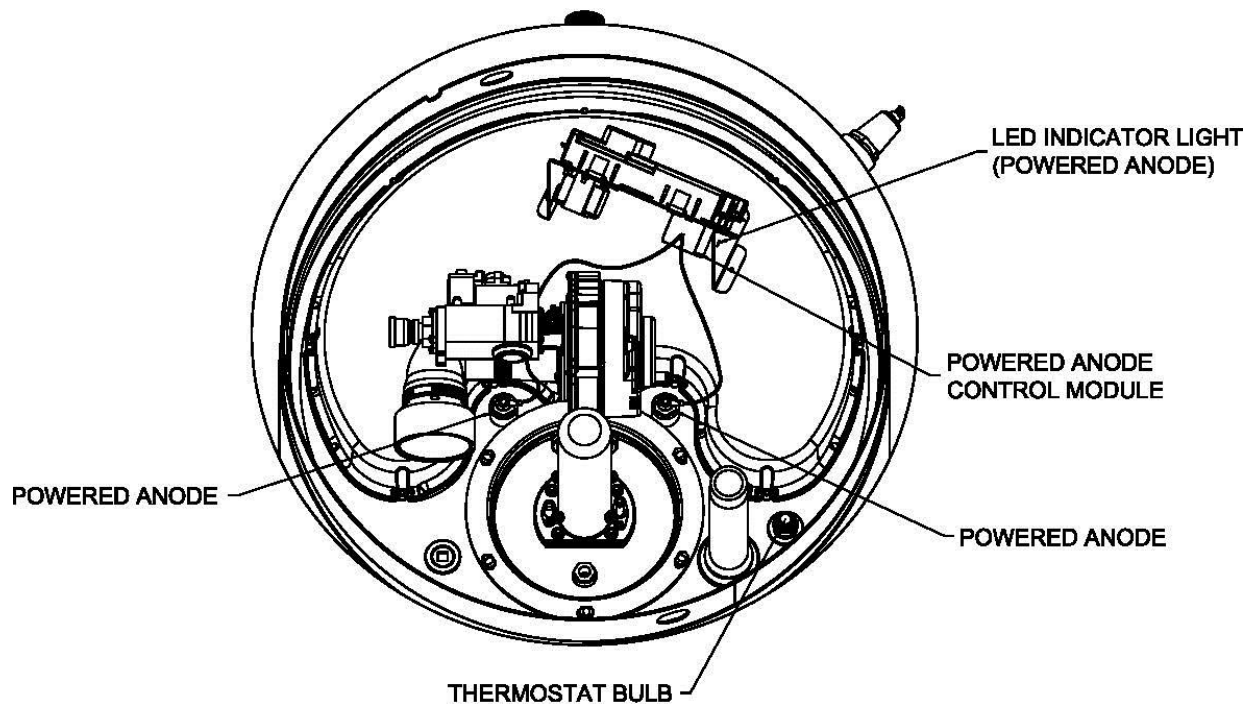
## Powered Anode System

These heaters are equipped with a powered anode system. The powered anode system provides corrosion protection to the tank by supplying a low voltage current to the titanium anode rods and then periodically comparing this current with the potential between the anode rod and tank wall to make corrections. The powered anode system is designed to extend the tank life without requiring anode rod replacement. The powered anode system consists of two titanium powered anode rods (31 7/8 in (81 cm) long), located in the front top of the water heater tank, and the powered anode control module located on the right side of the control panel.

The powered anode rod **must** have the electrical power supply connected at all times in order to provide corrosion protection to the water heater tank. If the electrical supply to the water heater is to be off for an extended period of time, the water heater must be drained. Turning off the lighted switch on the front panel to shut off the water heater will **not** turn off the powered anode system, as long as the line cord is plugged in and the breaker is left on.

The powered anode control module is located on the right vertical side of the control panel inside the surround panel. The control has a LED indicator light to show the status of operation. When the tank is filled with water and the power supply is on to the water heater, the light should have a steady green glow to indicate that protection current is flowing and operating normally. If the indicator light is not glowing, the power supply to the water heater or powered anode system is disconnected. Check the power supply or wire connections to the powered anode control.

If the control is flashing red, then there is a malfunction with the powered anode system. Make sure there are no bare spots in the wire insulation to the powered anode rods. Check all electrical connections. The powered anode rods are insulated from the water heater tank in the bushing. With an ohmmeter, check continuity between the powered anode terminal and the bushing. There should not be continuity. If there is continuity, replace the powered anode assembly.



**Figure 33 – Powered Anode Locations**  
(Jacket head removed for clarity)

## Temperature and Pressure Relief Valve

At least twice a year, the temperature and pressure relief valve should be checked to ensure that it is in operating condition. To check the relief valve, lift the lever at the end of the valve several times. The valve should seat properly and operate freely.

If water does not flow, remove and inspect for obstructions or corrosion. Replace with a new valve of the recommended size as necessary. A thorough inspection of the valve should be performed at least every three years by removing the temperature and relief valve from the tank. Do **NOT** attempt to repair the valve, as this could result in improper operation and a tank explosion. In areas with poor water conditions, it may be necessary to inspect the T&P valve more often than the recommended maintenance schedule.

### CAUTION

Before manually operating the valve, make sure that a drain line has been attached to the valve to direct the discharge to an open drain. Failure to take this precaution could mean contact with extremely hot water passing out the valve during this checking operation.

If the temperature and pressure relief valve on the water heater discharges periodically or continuously, it may be due to thermal expansion of water in a closed water supply system, or it may be due to a faulty relief valve.

Thermal expansion is the normal response of water when it is heated. In a closed system, thermal expansion will cause the system pressure to build until the relief valve actuation pressure is equaled. Then, the relief valve will open, allowing some water to escape, slightly lowering the pressure. Contact your water supplier or local plumbing inspector on how to control this situation.

### WARNING

**DO NOT** plug the temperature and pressure relief valve. This is **NOT** a solution and can create a hazardous situation.

## Vent and Air Intake System

Examine the vent and air intake system every 3 months. Points of inspection are as follows:

1. Check for obstructions and/or deterioration of vent piping and vent terminal. Replace immediately where needed.
2. Vent pipe and vent terminal screen should be cleaned of any foreign material. The screen is located inside the vent terminal outlet and is accessible from the outside of the vent terminal elbow. **Do NOT** reach inside the vent terminal when the water heater is in operation.
3. Check all venting system connections for leakage and reseal as required.

## Combustion System Inspection

Inspect the operation of the combustion system monthly. Use the following procedure to inspect the combustion system.

1. Adjust the thermostat to the minimum setting.
2. Turn OFF the main power switch of the water heater.
3. Remove the surround by unlatching it then lift it up and forward to remove.
4. Turn ON the main power switch.
5. Adjust thermostat to the maximum setting.
6. Watch the front display as the controller goes through the sequence of operations as previously described.
7. Upon ignition, observe the main burner flame.
8. Readjust thermostat to previous setting.
9. Replace surround on top and latch it securely in place.

---

## SECTION XI: DIAGNOSTIC AND TROUBLESHOOTING GUIDE

---

### Sequence of Operations

1. Thermostat calls for heat.
2. Combustion blower starts at a reduced RPM for a “soft” start light off.
3. Blower pre-purge period of approximately 15 seconds.
4. Ignition control board runs an internal verification safety check for approximately 15 seconds.
5. Trial for ignition (approximately 5 seconds per trial, 3 trials total):
  - a. Spark establishing period (3 seconds), gas valve opens, sparks from spark rod to ground rod, igniting the fuel air mixture at the burner surface.
  - b. Burner on, flame proving period (2 seconds). Requires a minimum of 1 microamp through the flame sense rod to prove flame.
  - c. If the blocked vent pressure switch contacts (normally closed) are open, then the ignition sequence will not start and error code “67” (pressure switch failed to close/open or vent safety switch failed to close/open) will flash once on the digital display. The unit will then go into pre-purge/“Hold” while the unit is waiting for the issue to be corrected. If the issue continues to occur, the digital display with flash error code “137” (pressure switch is open, or vent safety switch is open) while the unit is waiting to restart (5 minutes) the normal sequence of operation.
6. Once the flame signal is verified, the blower will remain at the “soft” start RPM for 5 seconds to stabilize the flame.
7. Steady state operation – Burner continues to operate until:
  - a. The thermostat circuit opens, gas valve closes, and blower continues to operate for 30 second post-purge period.
  - b. If the blocked vent pressure switch contacts open (normally closed) while the burner is on, then the gas valve closes, and the unit will retry a normal sequence of operation. If issue remains on restart, the unit will go into recycle as described in 5c.
8. The RPM of the blower will modulate depending on the heater demand. The control allows for a turn down ratio (TDR) of approximately 3:1. Generally, the blower will operate at higher speeds if the thermostat remains far from the setpoint and at lower speeds as the thermostat approaches the setpoint.
9. Thermostat is satisfied.
10. Gas valve closes and burner is extinguished.
11. Blower post purge for 30 seconds at maximum RPM.

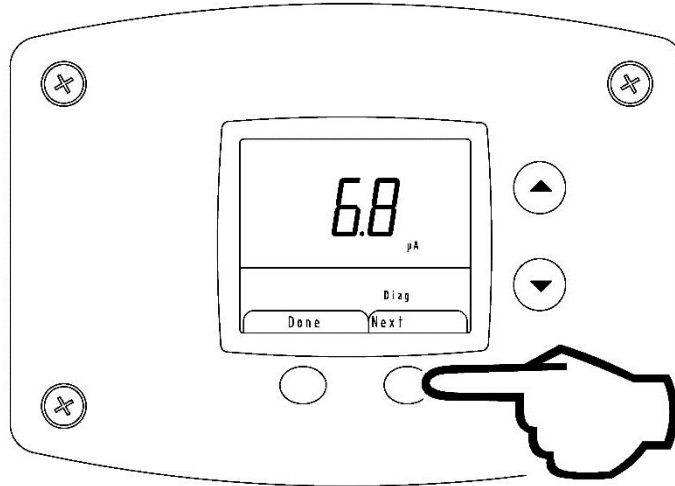
## Accessing Diagnostic Mode on the Water Heater Display (FOR SERVICE PERSONNEL ONLY)

The display has a “Diagnostic Mode” for accessing information in aiding servicing of the water heater. This procedure is for service and installation personnel only. To enter the Diagnostic Mode, follow the steps illustrated below:

### WARNING

The following procedure is for **service and installation personnel ONLY**. Resetting lockout conditions without correcting the malfunction can result in a hazardous condition.

**Step 1:** Press and hold the lower right button under “Next” in the lower right display for at least 3 seconds.



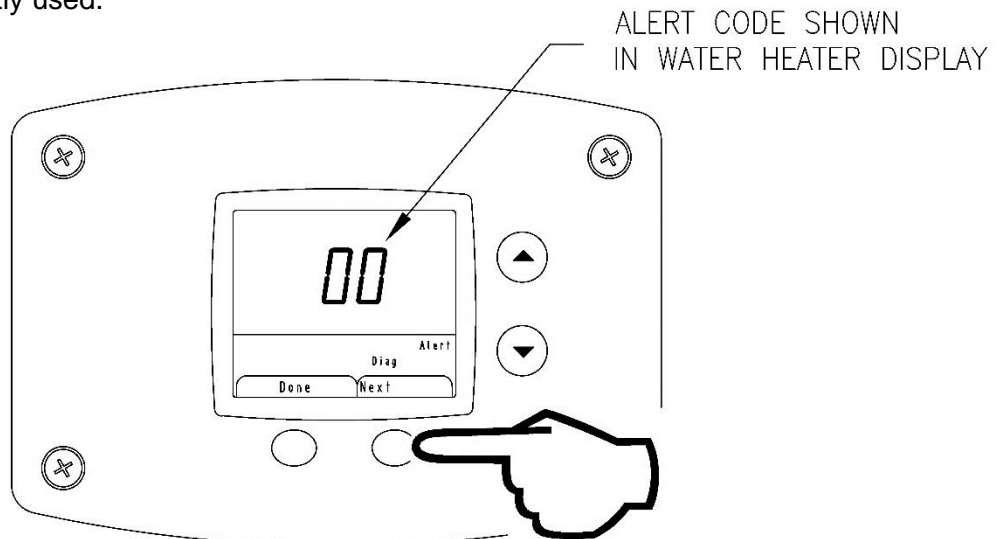
PRESS NEXT BUTTON FOR  
3 SECONDS TO ENTER

### NOTICE

The screens will stay in the Diagnostic Mode for 12.5 minutes after the last button press for viewing unless “Done” button is pressed to exit Diagnostic Mode.

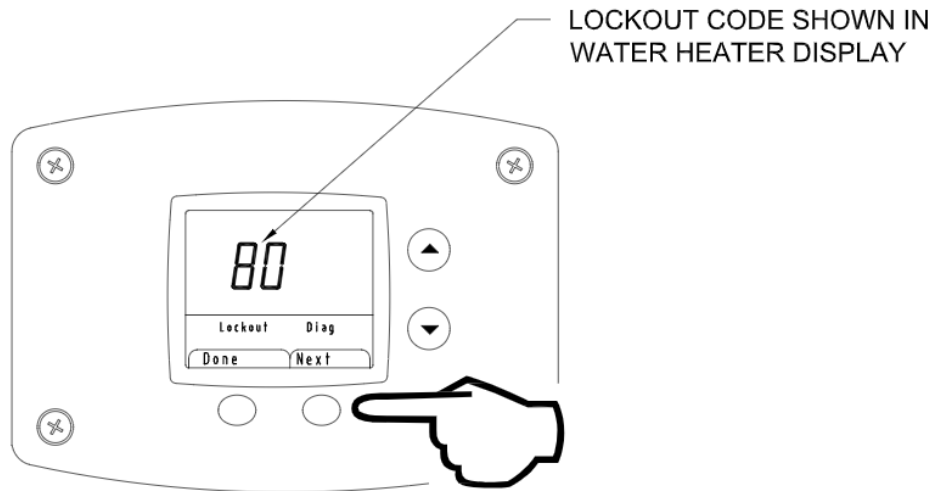
**Step 2:** The display will show the flame sense current in microamps when the burner is operating.

**Step 3:** Press the lower right “Next” button. The display will flash and show the number of any alert codes. These are not currently used.

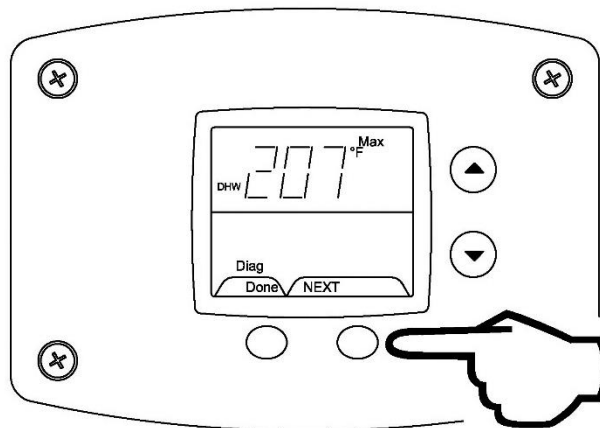




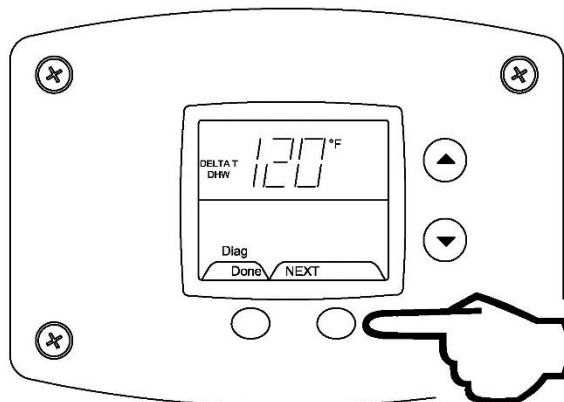
**Step 4:** Press lower right “Next” button. The display will flash and show the number of any Lockout codes.



**Step 5.** Press “Next”, the display will show “DHW MAX”. This is the maximum allowable temperature that the unit can get to before a lockout occurs.



**Step 6.** Press Next, display will show “DELTA T DHW”, this is the real time temperature reading of the tank.



**Step 7.** Press “Done” to exit Diagnostic Mode and return to the DHW setpoint in User Mode.

## NOTICE

The ICON control system can produce soft and hard lockouts. Soft lockouts are displayed if active and are not stored in Diagnostic Mode history. The control will periodically attempt to resume normal operation when in soft lockout conditions. If the system resumes normal operation a soft lockout will clear instantly; hard lockouts will display if active and require manual reset. Up to ten previous Hard lockouts are logged chronologically (newest first) in Diagnostic Mode history.

### Diagnostic Error Codes and Troubleshooting Procedures

Error Code	Definition of Code	Cause of Problem and Actions Taken to Correct
No code – blank display	No power to the unit or switch is off.	<ul style="list-style-type: none"> <li>• Check power supply to the water heater.</li> <li>• Make sure water heater is plugged in and the breaker is on.</li> <li>• Check if there is 120 volts power supply to the LINE connections on the control board.</li> <li>• Verify 24 volts at display.</li> <li>• Check for loose wires, defective transformer.</li> <li>• Check wire harness connections from display to the control board.</li> </ul>
9,22	Low flame sense signal	<ul style="list-style-type: none"> <li>• Check microamp output of flame sense</li> <li>• Inspect flame sensor and wire</li> <li>• Inspect burner for debris</li> </ul>
49	Voltage too low or high	<ul style="list-style-type: none"> <li>• Measure the incoming line voltage.</li> <li>• Voltage should be 115-125 volts.</li> <li>• If the voltage is not within this range or there is drastic fluctuation, then have the incoming power supply checked.</li> <li>• If the line voltage is satisfactory, check the output from the transformer to make sure it is 22-26 volts.</li> <li>• Replace transformer or wiring if defective.</li> </ul>
53	AC Inputs phase reversed	<ul style="list-style-type: none"> <li>• Check the module and display connections.</li> <li>• Check the module power supply and make sure that frequency, voltage and VA capacity of the transformer meet specifications.</li> <li>• Check to make sure the wiring connections on the control module from terminals J4-10 and J8-2 are connected together.</li> </ul>
62	Fan speed not proved	<ul style="list-style-type: none"> <li>• Check the pulse width modulation (PWM) wire harness connection from the blower to the control module.</li> <li>• Make sure the pin terminals make solid contact.</li> <li>• Measure the resistance of each wire in the wire harness from the terminal ends.</li> <li>• Replace wire harness if defective.</li> <li>• If value remains out of range, this hold will change to lockout 123 (defined below)</li> </ul>
67	Normally closed vent safety circuit opened	<ul style="list-style-type: none"> <li>• Check wiring to the normally closed blocked vent pressure switch and vent limit switch.</li> <li>• Use a voltmeter to find out if either the pressure switch or the high limit switch has opened.</li> <li>• If so, determine the cause (blocked vent terminal, clogged condensate drain, high temperature in compartment).</li> <li>• If limit switches are closed, check wiring for shorts.</li> <li>• Measure continuity.</li> <li>• If limit switches and wiring check O.K., replace control module.</li> </ul>
80	High Limit (Overheat Condition)	<ul style="list-style-type: none"> <li>• Check the wiring from the water temperature sensor to the control module.</li> <li>• Measure the resistance of each outside wire to the center wire. Measure the tank temperature and compare with the chart below.</li> <li>• If either outside wire has a much different resistance reading, replace the sensor.</li> <li>• Make sure the sensor is securely held inside the well with the clip.</li> <li>• If the problem persists and the sensor and wiring check O.K., then replace the control module.</li> </ul>

Error Code	Definition of Code	Cause of Problem and Actions Taken to Correct
93	Water temperature sensor fault	<ul style="list-style-type: none"> <li>• Appears after alert 172, defined below.</li> <li>• Check the water temperature sensor wire harness from the sensor to the control module.</li> <li>• Make sure there are no loose connections to the control plug.</li> <li>• Check the resistance reading from each of the outside wires to the center (common) wire. Measure the tank temperature and compare with the chart below.</li> <li>• If the ohm readings are not fairly close, replace the sensor.</li> <li>• Replace the control module if the problem persists and the sensor and wire connections are not defective.</li> </ul>
105	Flame detected out of sequence	<ul style="list-style-type: none"> <li>• Check to see if flame is present inside the combustion chamber before or after the ignition cycle.</li> <li>• If so, check to make sure the gas valve is wired correctly.</li> <li>• Check for voltage at the gas valve connection.</li> <li>• Replace the gas valve if defective.</li> <li>• If no flame is visible outside of the ignition sequence/run cycle, then make sure the flame sensor is wired to the correct terminal.</li> <li>• Make sure the ignition cable is not crossing the flame sensor wire or ignition ground wires.</li> <li>• If problem persists and all other checks have been verified, replace the control module.</li> </ul>
109, 110	Ignition Failure Occurred.	<ul style="list-style-type: none"> <li>• Burner failed to light or stay lit after 4 retries.</li> <li>• Hold condition – will reattempt ignition after 15 minute waiting period. A log will be stored in service history.</li> <li>• Check gas valve wiring and gas valve operation during the ignition cycle.</li> <li>• If burner lights but quickly goes out, check the flame sensor wire or the flame sensor.</li> <li>• If the flame sensor rod is badly corroded with deposits, clean with sandpaper or replace.</li> <li>• Check the inlet gas supply to make sure the pressure is sufficient and does not drop after the gas valve opens.</li> <li>• Make sure the combustion blower is operating during the ignition and run cycle.</li> <li>• Check the venting system to make sure the inlet and exhaust terminals and venting system is not blocked.</li> </ul>
122,123	Light-off Rate Proving Failed	<ul style="list-style-type: none"> <li>• If blower speed is not verified from the PWM (Pulse Width Modulation) signal within 5 minutes, the previously described error code “62” changes from a hold condition to this lockout code condition</li> <li>• Check the harness and pin terminals for a good connection to the control module.</li> <li>• Replace the blower or control module if the wire harness is good.</li> </ul>
137	Normally closed vent safety circuit opened	<ul style="list-style-type: none"> <li>• Refer to code 67</li> </ul>
172	Water temperature sensor resistance invalid	<ul style="list-style-type: none"> <li>• Hold 93 will be displayed if this value remains out of range</li> <li>• Measure the resistance of the water temperature sensor and compare it with the tank temperature using the chart below.</li> </ul>
NOTE		<ul style="list-style-type: none"> <li>• If there is do display, check primary/secondary voltage</li> <li>• Before troubleshooting always verify the following <ul style="list-style-type: none"> <li>○ Gas inlet pressure</li> <li>○ Static to dynamic gas pressure drop</li> <li>○ No vent and intake restrictions</li> <li>○ All wire connections are tight</li> <li>○ No grounded wires or missing grounds</li> <li>○ No water leaks</li> </ul> </li> </ul>

## Procedure for Checking Thermostat Sensor

Set the thermostat above water temperature (see temperature adjustment section) and observe system through one (1) complete cycle. Make sure system operates as desired.

To check the sensor, compare the resistance of the sensor wires (center wire with **yellow** marking to left and right **black** wires) as measured by an ohmmeter to the water temperature as measured by an accurate thermometer. Thermistor resistance increases as the temperature decreases. The tables below show the correct sensor resistance at various temperatures. Both thermistors in the sensor assembly should have approximately the same readings. Replace the sensor if the ohm reading in the chart does not approximate the reading from the sensor at the temperature measured in the tank. Use a thermometer or thermocouple to measure the temperature from the hot water outlet or temperature and pressure valve.

In Degrees F										
°F	0	1	2	3	4	5	6	7	8	9
40	26109	25400	24712	24045	23399	22771	22163	21573	21000	20445
50	19906	19383	18876	18383	17905	17440	16990	16553	16128	15715
60	15314	14925	14548	14180	13823	13477	13140	12812	12494	12185
70	11884	11592	11308	11032	10763	10502	10248	10000	9760	9526
80	9299	9078	8862	8653	8449	8250	8057	7869	7685	7507
90	7333	7165	7000	6839	6683	6531	6383	6238	6098	5961
100	5827	5697	5570	5446	5326	5208	5094	4982	4873	4767
110	4663	4562	4464	4368	4274	4183	4094	4006	3922	3839
120	3758	3679	3602	3527	3453	3382	3312	3244	3177	3112
130	3048	2986	2925	2866	2808	2752	3697	3643	2590	2538
140	2488	2439	2391	2344	2298	2253	2209	2166	2124	2083
150	2043	2004	1966	1928	1891	1856	1820	1786	1753	1720
160	1688	1656	1625	1595	1566	1567	1509	1481	1454	1427
170	1402	1376	1351	1327	1303	1280	1257	1235	1213	1191
180	1170	1150	1129	1110	1090	1071	1053	1035	1017	999
190	982	965	949	933	917	901	886	871	857	842
200	828	814	801	788	775	762	749	737	725	713

In Degrees C										
°C	0	1	2	3	4	5	6	7	8	9
0	32648	31026	29495	28049	26682	25389	24166	23010	21915	20879
10	19898	18968	18088	17253	16461	15710	14998	14322	13680	13071
20	12492	11942	11419	10922	10450	10000	9572	9165	8778	8409
30	8057	7722	7403	7099	6808	6532	6268	6016	5775	5546
40	5327	5117	4917	4726	4543	4368	4201	4042	3889	3742
50	3602	3468	3340	3217	3099	2986	2878	2774	2675	2579
60	2488	2400	2316	2235	2157	2083	2011	1942	1876	1813
70	1752	1693	1637	1582	1530	1480	1432	1385	1340	1297
80	1256	1216	1177	1140	1105	1070	1037	1005	974	944
90	916	888	861	835	810	786	763	741	719	698

Contact your local plumbing supplier or plumbing professional for replacement parts or contact the company at the address displayed on the rating plater of the water heater.

For faster and better service, please provide the part name, model, and serial number(s) of the water heater(s) when ordering parts.

**READ THE WARRANTY FOR A FULL EXPLANATION OF THE LENGTH OF TIME THAT PARTS AND THE WATER HEATER ARE WARRANTED.**

Manufactured under one or more of the following U.S. Patents: 5,277,171; 5,341,770; 5,372,185; 5,485,879; 5,574,822; 5,596,952; 5,660,165; 5,682,666; 5,761,379; 5,943,984; 5,954,492; 5,988,117; 6,056,542; 6,142,216; 6,442,178; 6,684,821; 6,935,280; 7,063,132; 7,063,133; 7,007,748; 7,270,087; 7,334,419; 7,337,517; 7,409,925; 7,458,341; 7,559,293; 7,621,238; 7,634,976; 7,650,859; 7,665,210; 7,665,211; 7,699,026; 7,866,168; 7,900,589; 7,971,560; 7,992,526 8,082,888; 8,146,772; Other U.S. and Foreign patent applications pending. Current Canadian Patents: 2,092,105; 2,107,012; 2,108,186; 2,112,515; 2,143,031; 2,239,007; 2,262,174; 2,314,845; 2,409,271; 2,476,685; 2,504,824; 2,548,958

Complete the following information and retain for future reference:

Model No: \_\_\_\_\_

Serial No: \_\_\_\_\_

Service Phone

Days: \_\_\_\_\_ Nights: \_\_\_\_\_

Address: \_\_\_\_\_

Supplier: \_\_\_\_\_

Supplier Phone No: \_\_\_\_\_

**Refer to the parts list on [www.bradfordwhite.com](http://www.bradfordwhite.com) for a complete parts listing and expanded views of the models covered in this manual.**





