

# LAARS-STOR<sup>®</sup> SERIES

Indirect Water Heaters



- ✓ Outstanding Performance
- ✓ Fast Recovery
- ✓ Superior Corrosion Resistance
- ✓ Limited Lifetime Warranty

**INTELLIGENTLY DESIGNED  
PERFORMANCE & RELIABILITY BUILT-IN**

**LAARS<sup>®</sup>**   
Heating Systems Company

# LAARS-STOR® SERIES *Indirect Water Heaters*

Since our beginning as Laars Engineering in 1948, Laars has embodied innovation and advancement in heating technology. We have built upon our technology over the past seventy plus years to ensure Laars products meet the demands of today's discerning customer. Laars stands behind each of its products with stringent quality standards which require each unit to be live-fired before it's packaged, and a service and support team that places the customer and their needs first – every time. Laars products are widely used in space heating, radiant floor heating, baseboard heating, radiators and water heating. Laars' 70+ years of experience, world class engineering, and customer support combine to make us your go-to experts in home heating. Laars brings comfort, reliability, and peace of mind to you and your home.



Laars® Heating Systems proudly offers industry leading, high volume, single-wall and double-wall indirect water heaters. All Laars-Stor models produce copious amounts of hot water - making them the perfect match for your boiler, heat pump or solar heating system. Whether the Laars-Stor indirect water heater is for use with an existing boiler system or new one, trust that you're choosing the best the industry has to offer.

## THE LAARS-STOR ADVANTAGE



### SAVE MONEY AND ENERGY

Indirect water heaters use the home's boiler, heat pump or solar heating system as the heat source. They are usually the least expensive way to provide hot water.



### HIGH PERFORMANCE

Laars-Stor models feature an extremely efficient heat exchanger made of a glass-lined carbon steel tubing or high grade stainless steel giving exceptional first hour delivery and high volumes of hot water.



### INSTALLATION EASE

These water heaters require no fuel or venting materials. They connect directly to an existing boiler.



### LOW PRESSURE DROP

Laars-Stor Series indirect water heaters were designed to minimize pressure drop so that customers get the hot water they want at the pressure they have come to expect.



### LIMITED LIFETIME WARRANTY

Laars-Stor models were designed and built for problem free and reliable service. We offer this warranty because of our confidence in the dependability and durability of the product.



### AHRI CERTIFIED

These water heaters are rated by the Air Conditioning, Heating and Refrigeration institute to provide accurate performance data generated by following the toughest industry standards.

# INTELLIGENTLY DESIGNED *Performance & Reliability Built-In*

Each Laars-Stor Series model includes the Laars Total Performance System that reduces sediment build-up, increases first-hour rating and minimizes temperature build-up in the tank. This results in higher efficiency, longer operational life and minimizes fuel bills.

**1 T&P RELIEF VALVE INSTALLED**

**2 STEEL TANK**

Heavy gauge steel automatically formed, rolled and welded to assure a continuous seam for glass lining.  
or

**STAINLESS STEEL TANK**

Long life, corrosion resistant titanium stabilized type 444 stainless steel alloy.

**3 PREMIUM INSULATION**

Up to 2 inches of non-CFC foam insulation results in superior heat retention, saving you money.

**4 SUPPLY AND RETURN CONNECTIONS**

Located on the front of the tank for easier and less cluttered connection to boiler.

**5 RELIABLE, HIGH OUTPUT HEAT EXCHANGER**

Select from stainless steel or glass lined material options to best match your home's hot water needs.

**6 INTEGRAL ADJUSTABLE AQUASTAT**

All Laars-Stor indirect tanks are supplied with fast-acting aquastats for precise and automatic temperature control. This ensures you have hot water when you need it!

**7 BRASS DRAIN VALVE**



**SAVE MONEY  
WITH REBATES  
& TAX CREDITS**



Find Rebates &  
Tax credits at  
**LAARS.COM**



## RESIDENTIAL SINGLE-WALL INDIRECT WATER HEATER

The ingenious Laars-Stor single wall was engineered to provide the lowest pressure drop, the highest hot water output and the highest amount of effective heat transfer area of any indirect fired water heater in the industry.



- **Heat Exchanger**—Single wall glass lined steel. 1-½" outside diameter.
- **Total Performance Sediment Reduction System**—Increases first hour delivery of hot water while minimizing temperature build-up at top of tank.
- **Three Protective Anode Rods**—Provides corrosion protection for long trouble-free service.
- **Enamel Glass Tank Lining**—For unsurpassed protection against corrosion, plus Microban® antimicrobial product protection to prevent the growth of bacteria, mold and mildew on the surface of the tank lining. Factory Installed Sediment Reduction System and Powered Anodes provide better performance and a longer life.
- **Immersed Adjustable Aquastat**—Supplied with a fast acting immersion aquastat for automatic temperature control.
- **Steel Tank**— Heavy gauge steel automatically formed, rolled & welded to assure a continuous seam for glass lining.
- **Potable Water Connections**—¾" NPT (120 Gallon 1" NPT) true dielectric connections on 8" centers.
- **Supply and Return Connections**— 1" NPT female connections located on the front of the water heater.
- **2" Non-CFC Foam Insulation**— Saves energy by dramatically reducing heat loss.
- **AHRI Certified Ratings**—Provides accurate performance data, based on the toughest industry standards, for proper comparison of products.
- **Brass Drain Valve.**
- **T&P Relief Valve Included**—All models feature opening on side of tank.
- **Limited Lifetime Warranty on Steel Tank and Heat Exchanger.**
- **Six Year Limited Warranty on Parts.**

Model Number	Capacity		A		B		C		D		E		F		G		Shipping Weight	
	U.S. Gal.	Liters	Jacket Diameter in.	Jacket Diameter cm.	Height Floor to Heater Top in.	Height Floor to Heater Top cm.	Height Floor to T&P Conn. in.	Height Floor to T&P Conn. cm.	Height Floor to Water Conn. in.	Height Floor to Water Conn. cm.	Height Floor to Exchanger Outlet in.	Height Floor to Exchanger Outlet cm.	Height Floor to Exchanger Inlet in.	Height Floor to Exchanger Inlet cm.	Height Floor to Aquastat in.	Height Floor to Aquastat cm.	Approx. lbs. kg.	
LS-SW-2-30-L	29	110	22	56	33½	85	28¼	72	34¾	87	5¾	14	27½	70	11½	30	164	74
LS-SW-2-40R-L	37	140	22	56	41½	104	34¾	87	41¾	106	5¾	14	27½	70	11½	30	185	85
LS-SW-2-50R-L	43	163	22	56	46¼	112	40¼	102	47	119	5¾	14	27½	70	11½	30	195	89
LS-SW-2-65-L	57	216	22	56	59¼	150	53¼	135	60	152	5¾	14	27½	70	11½	30	225	102
LS-SW-2-80-L	71	269	24	61	59	150	52¾	135	59¾	152	5¾	14	27½	70	11½	30	250	114
LS-SW-2-129-L	110	416	28¼	72	62½	159	55¾	142	63¼	161	6¾	16	28½	72	11½	30	370	167

AHRI Certified Water Heater Ratings

Model Number	First Hour Delivery @ 135°F (Gal.)	Continuous Draw Rating @ 135°F (Gal./Hr.)	Standby Heat Loss Rating (°F/Hr.)	Minimum Heat Req. Rate (BTU/Hr.)	Minimum Heat Source Flow Rate (Gal./Min.)
LS-SW-2-30-L	197	180	1.2	120,000	13.7
LS-SW-2-40R-L	205	180	1.1	120,000	13.7
LS-SW-2-50R-L	210	180	0.9	120,000	13.7
LS-SW-2-65-L	215	175	0.7	115,000	13.7
LS-SW-2-80-L	235	175	0.6	115,000	13.7
LS-SW-2-120-L	265	175	0.4	115,000	13.7

Heat Exchanger Head Loss

GPM	2	5	8	10	12
Ft. of Hd. Loss	0.01	0.20	0.50	0.80	1.50

DOE Water Heater Performance

Model Number	Maximum First Hour Rating (Gal.) @		Continuous Draw Rating (Gal./Min.) @		Approximate Boiler Output Needed for Rating (BTU/Hr.)
	140°F	115°F	140°F	115°F	
LS-SW-2-30-L	226	342	3.3	5.2	180,000
LS-SW-2-40R-L	235	351	3.3	5.2	180,000
LS-SW-2-50R-L	244	360	3.3	5.2	180,000
LS-SW-2-65-L	258	374	3.3	5.2	180,000
LS-SW-2-80-L	272	388	3.3	5.2	180,000
LS-SW-2-120-L	309	425	3.3	5.2	180,000

Note: AHRI Ratings are obtained with heat source output and flow rates shown and 180°F (82°C) boiler water supply temperature. DOE Performance is based on 200°F (93°C) boiler water temperature and 50°F (10°C) potable water inlet temperature.

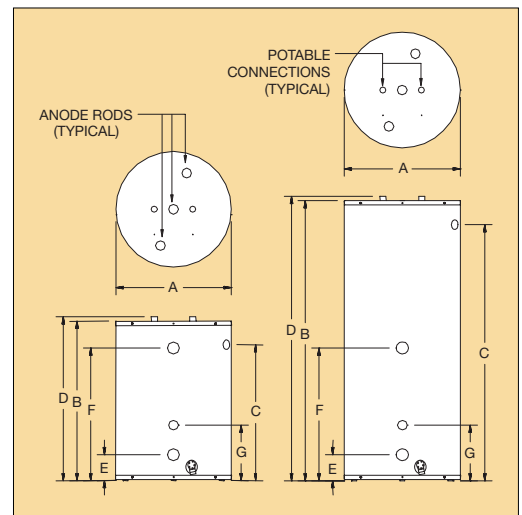

Microban® antimicrobial product protection helps prevent the growth of bacteria, mold and mildew that may affect the product. The built-in antimicrobial properties do not protect users or others from disease-causing organisms. Microban® is a registered trademark of Microban Products Company.

# LAARS-STOR2®

## RESIDENTIAL DOUBLE-WALL INDIRECT WATER HEATER

The Laars-Stor2 features a patented double-wall carbon steel heat exchanger coil coated with a glass-lining for corrosion resistance and long life. The Laars-Stor2 supplies a first hour rating of 110-145 gallons per hour.



- **Heat Exchanger**—Double wall 1½" O.D. glass coated steel coil. The double wall coil ensures that hydronic fluid remains separate from potable water.
- **Low Heat Exchanger Head Loss**—Greatly reduces the required pump size with 10 gpm max flow at less than 5 ft. of head.
- **Total Performance Sediment Reduction System**—Increases first hour delivery of hot water while minimizing temperature build-up at top of tank.
- **Enamel Glass Tank Lining**—For unsurpassed protection against corrosion, plus Microban® antimicrobial product protection to prevent the growth of bacteria, mold and mildew on the surface of the tank lining. Factory Installed Sediment Reduction System and Powered Anodes provide better performance and a longer life.
- **Fully Automatic Thermostat Controls**—Fast-acting surface-mount thermostat for automatic temperature control.
- **Water Connections**—¾" NPT factory installed true dielectric fittings. Extends water heater life and eases installation.
- **2" Non-CFC Foam Insulation**—Save energy by dramatically reducing heat loss.
- **Two Protective Aluminum Rods**—Provides added protection against corrosion for long trouble-free service.
- **Supply and Return Connections**—¾" NPT female connections are located on the front of the water heater.
- **AHRI Certified Ratings**—Provides accurate performance data, based on the toughest industry standards, for proper comparison of products.
- **Brass Drain Valve.**
- **T&P Relief Valve Included**—All models feature opening on side of tank.
- **Steel Tank**—Heavy gauge steel automatically formed, rolled and welded to assure a continuous seam for glass lining.
- **Limited Lifetime Warranty on Steel Tank and Heat Exchanger.**
- **Six Year Limited Warranty on Parts.**

## Residential Laars-Stor2®

Model Number	Capacity		A		B		C		D		E		F		G		Shipping Weight	
	U.S. Gal.	Liters	Floor to Heater Top		Jacket Diameter		Floor to T&P Conn.		Floor to Water Conn.		Floor to Boiler Outlet		Floor to Boiler Inlet		Floor to Thermostat		Approx. lbs. kg.	
			in.	cm.	in.	cm.	in.	cm.	in.	cm.	in.	cm.	in.	cm.	in.	cm.		
LS-DW240L-464	37	140	41	104	22	56	34 <sup>7</sup> / <sub>8</sub>	87	41 <sup>7</sup> / <sub>8</sub>	108	5 <sup>3</sup> / <sub>8</sub>	14	27 <sup>1</sup> / <sub>2</sub>	70	11 <sup>1</sup> / <sub>2</sub>	29	195	89
LS-DW250L-464	43	163	46 <sup>1</sup> / <sub>4</sub>	117	22	56	40 <sup>1</sup> / <sub>8</sub>	102	47 <sup>1</sup> / <sub>4</sub>	120	5 <sup>3</sup> / <sub>8</sub>	14	27 <sup>1</sup> / <sub>2</sub>	70	11 <sup>1</sup> / <sub>2</sub>	29	205	93
LS-DW265L-464	57	216	59	150	22	56	53 <sup>1</sup> / <sub>8</sub>	135	60	153	5 <sup>3</sup> / <sub>8</sub>	14	27 <sup>1</sup> / <sub>2</sub>	70	11 <sup>1</sup> / <sub>2</sub>	29	235	107
LS-DW280L-464	71	269	59	150	24	61	52 <sup>7</sup> / <sub>8</sub>	134	59 <sup>3</sup> / <sub>4</sub>	152	5 <sup>3</sup> / <sub>8</sub>	14	27 <sup>1</sup> / <sub>2</sub>	70	11 <sup>1</sup> / <sub>2</sub>	29	255	116

AHRI Certified Water Heater Ratings

Model	First Hour Rating @ 135°F (Gal./Hr.)	Continuous Draw Rating @ 135°F (Gal./Hr.)	Standby Heat Loss Rating (°F/Hr.)	Minimum Heat Req. Rate (BTU/Hr.)	Minimum Heat Source Flow Rate (Gal./Min.)
LS-DW240L-464	110	85	1.1	58,000	8.0
LS-DW250L-464	120	85	0.9	58,000	8.0
LS-DW265L-464	135	85	0.7	58,000	8.0
LS-DW280L-464	145	85	0.6	58,000	8.0

Heat Exchanger Head Loss

GPM	2	5	8	10	12
Ft. of Hd. Loss	0.20	0.94	2.40	3.80	5.40

DOE Water Heater Performance

Model	Maximum First Hour Rating (Gal./Hr.) @ 140°F 115°F	Continuous Draw Rating (Gal./Hr.) @ 140°F 115°F	Approximate Boiler Output Needed For Ratings (BTU/Hr.)
LS-DW240L-464	116 164	1.5 2.3	80,000
LS-DW250L-464	123 171	1.5 2.3	80,000
LS-DW265L-464	132 180	1.5 2.3	80,000
LS-DW280L-464	142 190	1.5 2.3	80,000

Note: AHRI Ratings are obtained with heat source output and flow rates shown and 180°F (82°C) boiler water supply temperature. DOE Performance is based on 200°F (93°C) boiler water temperature and 50°F (10°C) potable water inlet temperature.

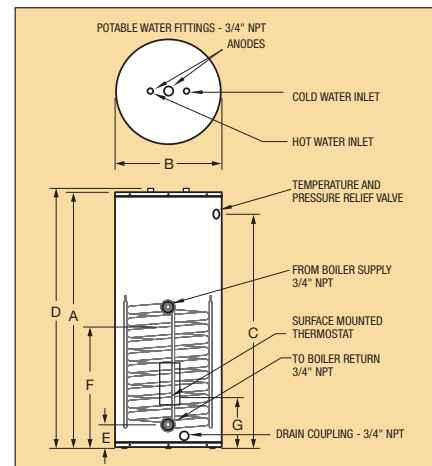

Microban® antimicrobial product protection helps prevent the growth of bacteria, mold and mildew that may affect the product. The built-in antimicrobial properties do not protect users or others from disease-causing organisms. Microban® is a registered trademark of Microban Products Company.

# LAARS-STOR® SS

## STAINLESS STEEL INDIRECT WATER HEATER

The Laars-Stor SS utilizes a superior grade of type 444 passivated stainless steel for the tank and the heat transfer coil. This construction is lightweight and also resists pitting while minimizing inter-granular and stress corrosion. The Laars-Stor SS models provide superior thermal conductivity for higher efficiency.



- **Stainless Steel Tank and Heat Exchanger**—Made from chromium molybdenum - titanium ferritic 444 stainless steel alloy.
- **Stainless Steel Heat Exchanger**—Single-wall 1" (25mm) O.D. stainless steel coil. Maximum supply temperature from the boiler must not exceed 240°F (116°C).
- **Factory Installed Sediment Reducing Inlet Tube**—Sediment reducing device that also increases first hour rating of hot water while minimizing temperature build-up in tank (excluding LS-SS-120-L).
- **Immersed Adjustable Aquastat**—Supplied with a fast acting immersion aquastat for automatic temperature control (adjustable from 80-160°F / 27-71°C).
- **Supply and Return Connections**—1" NPT female connections are located on the front for both the boiler supply and boiler return.
- **Insulation System**—2" (51mm) Non-CFC foam insulation covers the sides and top of the tank, reducing heat loss. This results in less energy consumption, improved efficiencies, and jacket rigidity.
- **Potable Water Connections**—3/4" NPT (1" NPT on LS-SS-120-L).
- **T&P Relief Valve**—Included.
- **Low Restrictive Brass Drain Valve**—Durable tamper proof design (excluding the LS-SS-120-L).
- **AHRI Certified Ratings**—Provides accurate performance data, based on the toughest industry standards, for proper comparison of products.
- **Limited Lifetime Warranty on Tank and Heat Exchanger.**
- **Six Year Limited Warranty on Parts**
- **Five Year Limited Warranty on Commercial Models.**
- **One Year Limited Warranty on Parts on Commercial Models.**

AHRI Certified Water Heater Ratings

Model Number	First Hour Delivery Rating	Continuous Draw @ 135°F	Standby Heat Loss Rating	Minimum Heat Required Rate	Minimum Heat Source Flow Rate
	Gal./Hr.	Gal./Hr.	°F/Hr.	BTU/Hr.	Gal./Min.
LS-SS-30-L	179	160	0.8	105,000	14.0
LS-SS-40-L	237	209	0.6	135,000	14.0
LS-SS-50-L	269	229	0.5	145,000	14.0
LS-SS-75-L	367	307	0.4	193,000	14.0
LS-SS-120-L	409	319	0.3	199,000	9.0

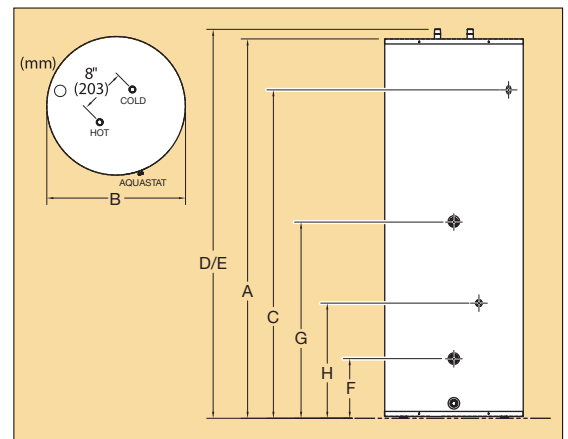

Model Number	Capacity		A		B		C		D		E		F		G		H		Shipping Weight	
	U.S. Gal.	Liters	in.	mm.	in.	mm.	in.	mm.	in.	mm.	in.	mm.	in.	mm.	in.	mm.	in.	mm.	lbs.	kg.
LS-SS-30-L	29	110	31½	803	24	610	22½	572	32½	826	32½	826	10	254	22½	575	16½	419	75	34
LS-SS-40-L	38	142	38¼	972	24	610	29½	740	38¾	987	38¾	987	10	254	24¾	629	18¾	476	91	41
LS-SS-50-L	50	189	48	1219	24	610	39¾	1010	48¾	1241	48¾	1241	10	254	29¼	743	19½	495	103	47
LS-SS-75-L	73	274	65½	1667	24	610	56½	1435	66¼	1683	66¼	1683	10	254	33⅝	854	19½	495	142	64
LS-SS-120-L	111	420	63¾	1610	30¼	768	65¼	1670	53½	1359	2⅞	68	11¾	299	40	1016	31⅜	797	217	98

# HEAT AND HOT WATER FOR ANY SITUATION

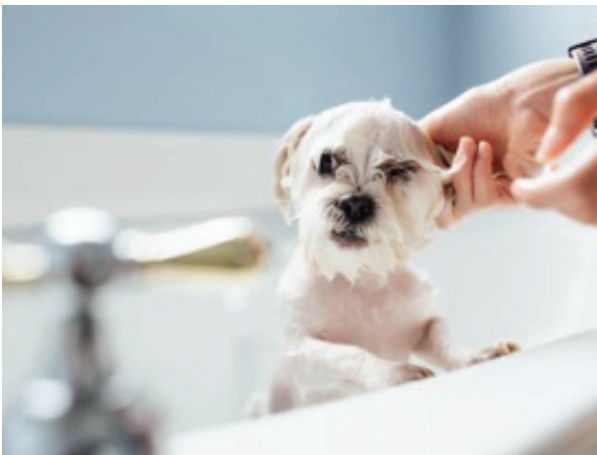

FT Series  
Heat Only Model



Laars-Stor®  
Indirect Water Heater

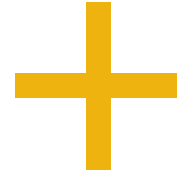

For homes with very large domestic hot water demands, such as hot tubs or giant soaking tubs, Laars can meet the need!

Pair the Laars FT Series heating boiler with a Laar-Stor® Indirect Water Heater for a high efficiency, high output domestic hot water solution. The FT Series boiler is used to heat the domestic water inside the Laars-Stor tank, efficiently creating a large amount of domestic hot water at the ready, when you need it!

Choose from either glass-lined carbon steel or high grade stainless steel construction to best meet your water chemistry, both versions give exceptional first hour delivery and high volumes of hot water.

**FT Series  
Learn More Here!**



**Notes:** AHRI certified ratings were obtained with a heat source output rate and flow rate as specified and a 180°F boiler water supply temperature. Other results will be obtained under different conditions.

Meets or exceeds the insulating standards established under ASHRAE Standard 90.1 b (current edition).

All units are certified at 300 PSI test pressure (2068 kPa) and 150 PSI working pressure (1034 kPa).

**Warranty:** For products installed in USA, Canada, and Puerto Rico. Some states do not allow limitations on warranties.

See complete copy of the warranty included with the heater.

**Dimensions and specifications subject to change without notice in accordance with our policy of continuous product improvement.**

**Suitable for Water (Potable) Heating and Space Heating**

Toxic chemicals, such as those used for boiler treatment, shall NEVER be introduced into the potable water side. The potable side of this unit may NEVER be connected to any existing heating system or component(s) previously used with a non-potable water heating appliance. The heat exchanger side of the unit may be used in space heating applications.

**Notes:** DOE water heater performance ratings are based on 200°F boiler water temperature and 50°F potable water inlet temperature.



**VIEW OUR ENTIRE PRODUCT LINE AT  
WWW.LAARS.COM**



Browse Laars-Stor  
Series



**Customer Service and Product Support:** 800.900.9276 • Fax 800.559.1583  
**Headquarters:** 20 Industrial Way, Rochester, NH 03867 • 603.335.6300 • Fax 603.335.3355  
9 Brigden Gate, Halton Hills, Ontario, Canada, L7G 0A3 • 905.203.0600 • Fax 905.636.0666  
[www.LAARS.com](http://www.LAARS.com)