

Installation and Operation
Instructions for

Mini-Therm II™

Residential
Gas-Fired
Hydronic Boilers

Models JVS, JVT
Sizes 50-225

U.S. Patent No. 1,609,692
Canada Patent No. 383,318

Vent damper is optional in some provinces of Canada.
These instructions are to be stored in the packet
provided on the boiler.

FOR YOUR SAFETY: This product must be installed and serviced by a professional service technician, qualified in hot water boiler installation and maintenance. Improper installation and/or operation could create carbon monoxide gas in flue gases which could cause serious injury, property damage, or death. Improper installation and/or operation will void the warranty.

⚠ WARNING

If the information in this manual is not followed exactly, a fire or explosion may result causing property damage, personal injury or loss of life.

Do not store or use gasoline or other flammable vapors and liquids in the vicinity of this or any other appliance.

WHAT TO DO IF YOU SMELL GAS

- Do not try to light any appliance.
- Do not touch any electrical switch; do not use any phone in your building.
- Immediately call your gas supplier from a nearby phone. Follow the gas supplier's instructions.
- If you cannot reach your gas supplier, call the fire department.

Installation and service must be performed by a qualified installer, service agency, or gas supplier.

⚠ AVERTISSEMENT

Assurez-vous de bien suivre les instructions données dans cette notice pour réduire au minimum le risque d'incendie ou d'explosion ou pour éviter tout dommage matériel, toute blessure ou la mort.

Ne pas entreposer ni utiliser d'essence ni d'autres vapeurs ou liquides inflammables dans le voisinage de cet appareil ou de tout autre appareil.

QUE FAIRE SI VOUS SENTEZ UNE ODEUR DE GAZ:

- Ne pas tenter d'allumer d'appareils.
- Ne touchez à aucun interrupteur. Ne pas vous servir des téléphones dans le bâtiment où vous vous trouvez.
- Appelez immédiatement votre fournisseur de gaz depuis un voisin. Suivez les instructions du fournisseur.
- Si vous ne pouvez rejoindre le fournisseur de gaz, appelez le service des incendies.

L'installation et l'entretien doivent être assurés par un installateur ou un service d'entretien qualifié ou par le fournisseur de gaz.

TABLE OF CONTENTS

SECTION 1.

General Information

1.1	Introduction	3
1.2	Warranty	3
1.3	Codes and Standards	3
1.4	Technical Assistance	3
1.5	Materials Installer Must Provide	3
1.5.1	Materials for All Installations	3
1.5.2	Materials for <i>Most</i> Installations	3
1.5.3	Diagnostic Tools	4
1.6	Specifications	4
1.6.1	General Specifications	4
1.6.2	Dimensions	4

SECTION 2.

Installation Instructions

2.1	Introduction	4
2.2	Field Assembly	5
2.3.1	Clearances	6
2.3.2	Flooring	6

SECTION 3.

Venting

3.1	Combustion Air Supply	7
3.2	Exhaust Venting	7
3.3	Vent Pipe Sizing and General Installation	8
3.4	Common Venting Systems	8
3.4.1	Venting Multiple Appliances	8
3.4.2	Inspection of Commonly Vented Appliances	9

SECTION 4.

Gas Connections

4.1	Gas Supply and Piping	10
4.2	Special Precautions for LP Gas	11

SECTION 5.

Water Connections

5.1	Water Piping	12
5.1.1	By-pass Piping	12
5.2	Alternate Auto-Bypass Operation	12
5.3	Flow Requirements	15
5.4	Chilled Water Systems	16
5.5	Oxygen Permeable Systems	16
5.6	Anti-Freeze	16

SECTION 6.

Electrical

6.1	General Information	16
6.2	Main Power	16
6.3	Grounding	21
6.4	Auxiliary Devices	21
6.4.1	Flow Switch	21
6.4.2	Heat Anticipator	21

SECTION 7.

Operating Instructions

7.1	Normal Operation	21
7.2	Start-up	22
7.2.1	Filling the System	22
7.2.2	Boiler Start-up	22
7.3	Lighting and Shutdown Procedures	23
7.3.1	Lighting the Boiler	23
7.3.2	Shutdown	24
7.3.2.1	Main Burner Shutdown (JVT Only)	24
7.3.2.2	Complete Shutdown	24
7.4	High Altitude Burner Air Shutter Adjustment	24

SECTION 8.

Maintenance

8.1	General Maintenance	25
8.2	Boiler Components and Their Operation	26

SECTION 9.

Troubleshooting

9.1	General Boiler Troubleshooting	27
9.2	Troubleshooting Guide	28
9.3	Troubleshooting Honeywell S8600 Intermittent Pilot System	29
9.4	Electrical Troubleshooting	30

SECTION 10.

Glossary

10.1	Glossary of Terms	30
------	-------------------------	----

SECTION 11.

Replacement Parts

11.1	Ordering Information	31
11.2	Parts List	31
11.3	Exploded View	34

SECTION 1. General Information

1.1 Introduction

This manual provides information necessary for the installation, operation, and maintenance of Laars Model JV copper tube hydronic boilers.

All application and installation procedures should be reviewed completely before proceeding with the installation. Consult the Laars factory, or local factory representative, with any problems or questions regarding this equipment. Experience has shown that most operating problems are caused by improper installation.

These boilers are available in two configurations; the JVT has a thermocouple/continuous burning pilot, and the JVS has an electronic intermittent ignition device (I.I.D.). Look for the model designation on the rating plate, which can be found on top of the boiler in the right rear corner. If the unit is part of a Mini-Combo II (model MC) Residential Gas-Fired Space/Water Heater, refer also to Document 8001, Mini-Combo II Installation and Operation Instructions.

The Laars automatic vent dampers are standard on all U.S. and Canadian models. The Laars side wall power venters can be used on both JVS and JVT models. Special instructions for their installation are included in the vent damper and power venter package. Read them carefully before installation.

1.2 Warranty

The Laars Model JV boilers are covered by a limited warranty. The owner should fill out the warranty registration card and return it to Laars.

All warranty claims must be made to an authorized Laars representative or directly to the factory. Claims must include the boiler serial number and model (this information can be found on the rating plate), installation date, and name of the installer. Shipping costs are not included in the warranty coverage.

Some accessory items are shipped in separate packages. Verify receipt of all packages listed on the packing slip. Inspect everything for damage immediately upon delivery, and advise the carrier of any shortages or damage. Any such claims should be filed with the carrier. The carrier, not the shipper, is responsible for shortages and damage to the shipment whether visible or concealed.

The warranty does not cover damage caused by improper assembly installation, operation or field modification.

1.3 Codes and Standards

The JV Hydronic Boiler (or Mini-Therm II) is design certified by CSA (Canadian Standards Association) as complying with the latest edition of

the "Standard for Gas Fired Low Pressure Steam and Hot Water Boilers", ANSI Z21.13 in the USA and CAN1-4.9 in Canada.

All Laars boilers must be installed in accordance with the local building and installation codes as per the utility or authorities having jurisdiction. All local codes take precedence over national codes.

In the absence of local codes, refer to the following national codes for installation:

1. In the United States, the latest edition of "The National Fuel and Gas Code", ANSI Z223.1. Specifically, refer to Chapter 10, "Venting of Equipment".
2. In Canada, the latest edition of "The Installation Codes for Gas Burning appliances and Equipment", CSA B149.1.

Any changes to the boiler, gas controls, gas orifices, wiring, draft diverter, or improper installation may void the warranty. If change is required to any of the above, consult the factory.

1.4 Technical Assistance

Consult Laars Heating Systems or your local Laars factory representative with any questions or problems involving the specifications, installation, and operation of your Laars equipment. An experienced technical support staff is ready to assist you in assuring the proper performance and application of Laars products. For technical support call the Laars Heating Systems Technical Service Department.

1.5 Materials Installer Must Provide

1.5.1 Materials for All Installations

The following items are needed and are to be supplied by the installer for all Mini-Therm II boiler installations:

1. The correct size gas pipe to supply the gas to the boiler (see Section 4.1 for correct gas pipe size).
2. A CSA listed manually operated gas valve to be installed in the gas line outside of the boiler jacket.
3. A suitable gas union joint or other removable connector to connect the boiler to the gas line outside of the boiler.
4. Plumbing items needed to provide a sediment trap (drip leg) in the gas line between the manual gas valve and the union to the boiler.
5. A 115 VAC power supply. A junction box is not needed at the boiler, connections are made inside of the boiler's control panel (see Figure 8).
6. Vent pipe of the same or larger diameter as the vent damper or draft diverter outlet (see Section 3.3 for venting instructions).

1.5.2 Materials for *Most* Installations

In addition to the items listed above, the following items may be needed:

1. Plumbing materials for the bypass piping, which is **required** for:
 - a. Any system where the return water temperature may be less than 120°F, such as in-floor radiant systems, snow melt systems or other systems where a “cold start” is expected frequently due to thermostat setbacks, etc. See Figure 11.
 - b. Any system where the temperature rise across the heat exchanger is above 30°F (see Section 5 and Figure 7).
2. Combustion air grates for openings sized in accordance with Section 3.1.
3. Field interlock wiring for any motorized combustion air louvers to ensure the boiler does not fire if motorized louvers do not open.
4. A suitable non-combustible base if installed on a combustible floor (see Section 2.3.2)

1.5.3 Diagnostic Tools

The following materials are needed to verify correct installation:

1. Gas manometer to verify gas pressure
2. Strap-on, digital or infrared thermometer to check temperature rise across the heat exchanger.
3. Suggested: Draft gauge and combustion test equipment.

1.6 Specifications

1.6.1 General Specifications

1. Installation Location:
Certified for use in Indoor Applications only
2. Minimum Clearance From Combustible Material:
See Table 1 in Section 2.3.1.
3. Supply Gas Type:
Certified for use with Natural Gas and LP Gas
4. Gas Pipe/Boiler Gas Valve Connection:

	Nat	LP
50-225	½" NPT	½" NPT
5. Inlet Gas Supply Pressure:

	Minimum	Maximum
Natural Gas:	5.5" WC	10.5" WC
LP Gas:	10.0" WC	13.0" WC
6. Water Pipe/Boiler Connection:
1 ¼" NPT
7. Water Flow Rate:
See Table in Section 5.2
8. Pressure Relief Valve:
30 PSI
9. Recommended system pressure:
12 PSI
10. Exhaust Vent Connection Size:

50	4" Diameter
75-100	5" Diameter
125-160	6" Diameter
225	7" Diameter

11. Electrical Supply:
115 Volts AC
12. Modification of Boiler for High Altitude:
Mini-Therm II Boilers are normally shipped from the factory in the low altitude (sea level) operational configuration. When requested, the boilers can be configured and shipped for higher altitudes. For field conversions to change altitude configurations, conversion parts are available from Laars. For more information or call the Customer Service Department.

1.6.2 Dimensions

See Figure 1 for a diagram showing the boiler's exterior dimensions and dimensions to critical connections on the boiler.

SECTION 2. Installation Instructions

2.1 Introduction

WARNING

Improper installation or maintenance can cause nausea or asphyxiation from carbon monoxide in flue gases which could result in severe injury, or death.

AVERTISSEMENT

Une installation ou un entretien in adéquat peut causer la nausée ou l'asphyxie en raison du monoxyde de carbone présent dans les gaz de combustion et même entrainer des blessures graves ou la mort.

Install the Mini-Therm II boilers and vent dampers in accordance with the procedures in this manual, local codes and ordinances, and in accordance with the latest edition of the appropriate national code (see Section 1.3 “Codes and Standards”).

All gas-fired products require correct installation to assure safe operation. The requirements for boilers include the following:

1. Field assembly
2. Appropriate site location (clearances) and flooring
3. Sufficient combustion and ventilation air
4. Properly sized gas meter and piping
5. Proper electrical wiring (if required)
6. Adequate water flow

This manual provides the information needed to meet these requirements. Review all application and installation procedures completely before continuing the installation.

NOTE: The Mini-Therm II boiler is approved for indoor installation only.

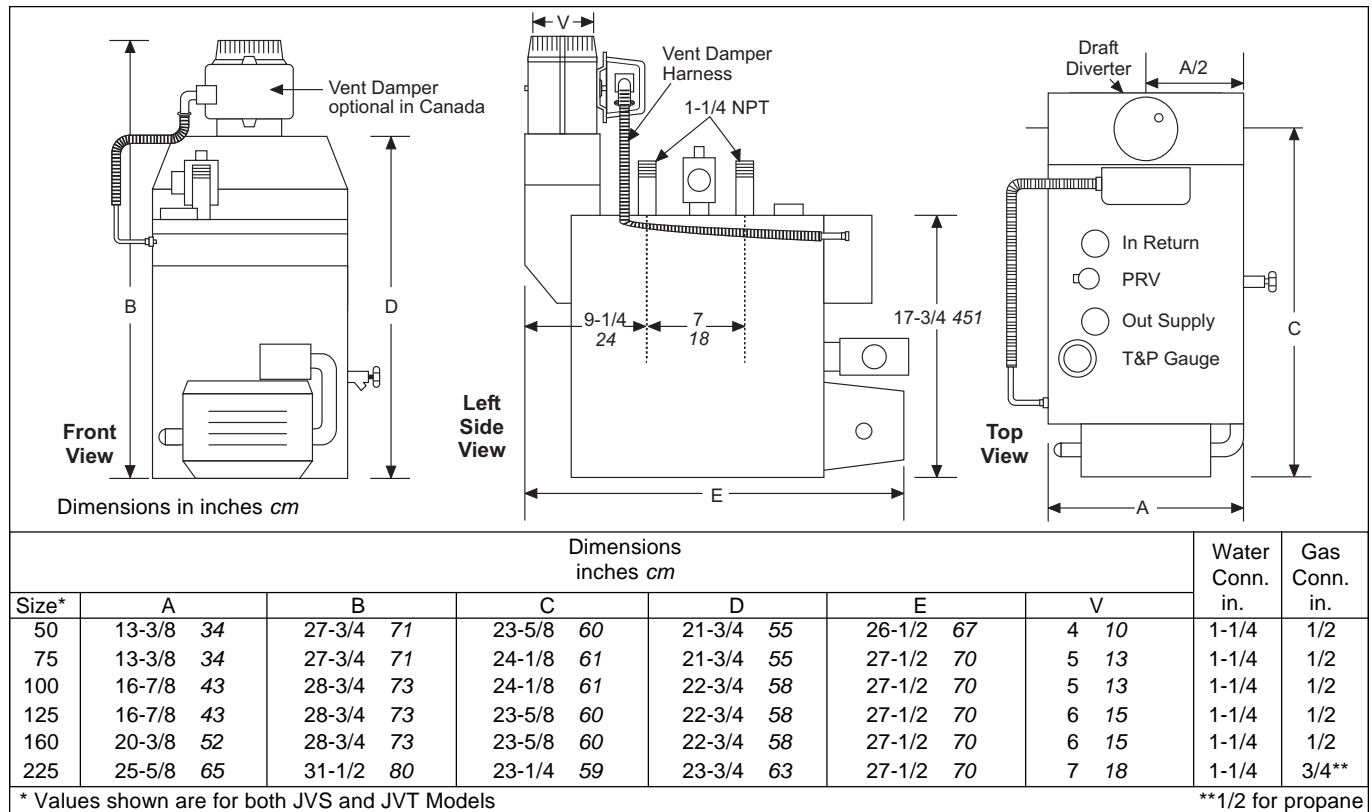

Figure 1. Dimensional Information.

2.2 Field Assembly

- Mini-Therm II boilers have built-in draft diverter for natural draft operation.
- Find the vent damper box which is located in the boiler package.
- Install the vent damper directly to the top of the draft diverter outlet with the damper operator facing to the front of the boiler, and with the flow direction arrow pointing upward. Use the vent damper wire harness provided with the boiler to connect the vent damper to the boiler. The bracket end of the harness should be connected to the vent damper actuator.
- For Model JVS only: Install the metal plug provided with the vent damper onto the damper plate hole. Disregard the metal plug in case of standing (continuous) pilot boilers. **For all JVT models, the damper plate hole should never be blocked.**
- Do not modify the automatic vent damper device. It is very important that no other vents are closed. Provide at least six inches clearance between the automatic vent damper and combustible construction, and be sure to allow access for servicing the damper.
- Install the temperature/pressure gauge provided in the parts box.

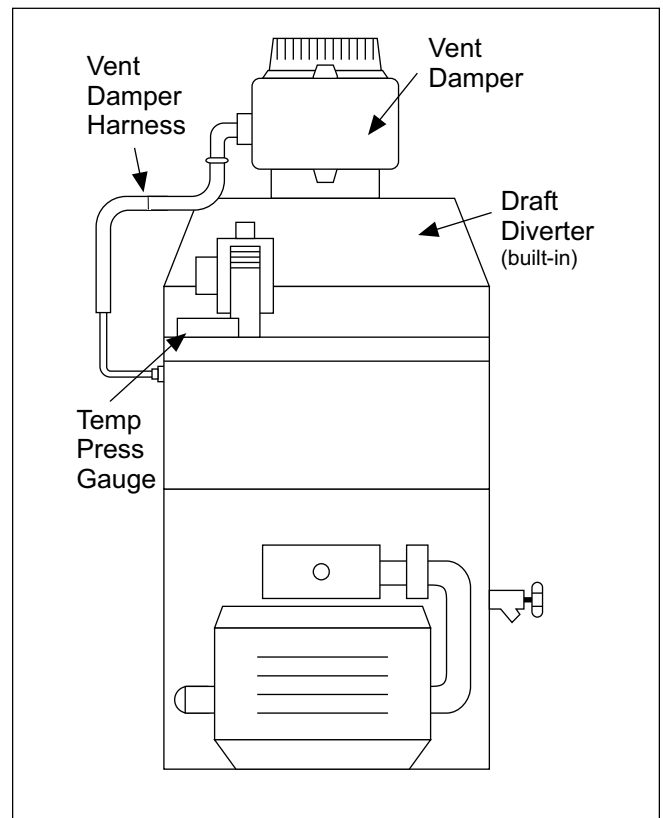

Figure 2. Field Assembly Items.

⚠ Caution

Do not force motor operation when operator is fastened to the damper by moving the damper blade, turning the shaft or by turning the position indicator.

⚠ Attention

Ne pas tourner le registre manuellement avec ou sans courant électrique ou le moteur sera endommagé.

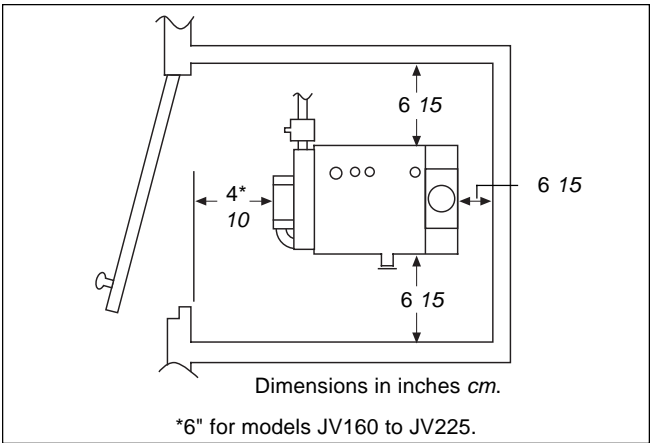

Figure 3. Closet and Alcove Installation (see Table 3).

2.3.1 Clearances

The boiler must be placed to provide clearances on all sides for maintenance and inspection. There must also be minimum distances maintained from combustible surfaces (see Table 1).

Boiler Sizes	50-125		160-225	
	in	cm	in	cm
Left side	6	15	6	15
Right side	6	15	6	15
Rear	6	15	6	15
Front	4	10	6	15
Flue	6	15	6	15
Top	23	48	36	91

Note: Clearances listed in Table 1 are manufacturer’s tested values. These are given as minimum values. Where local and national codes apply, and values are different than those listed in Table 1, use the greater value to ensure safe operation.

Table 1. Minimum Boiler Clearances From Combustible Surfaces.

Dégagements Minimaux à Assurer Entre Ics Parois de L'appareil et les Constructions Combustibles

At least 15" (381mm) access must be available in front of the boiler for burner removal. Consult local codes for clearances to hot water pipes and accessories.

If the boiler is to be installed in a garage, all burners and burner ignition devices must have a minimum 18" (457mm) clearance above the floor.

The Model JV-50 through JV-100 boilers can be installed in a closet, as long as the minimum clearances shown in Table 1 and Figure 3 are observed. Special attention should be paid to clearances between the front of the boiler and the closet door when it is closed.

Consult the American National Standard Z21.13 for more information concerning closet installations. In Canada, refer to the latest edition of CSA-B149.1.

2.3.2 Flooring

The boiler shall be installed on a **level** floor of noncombustible construction or on fire-resistant slabs or arches. Noncombustible flooring is defined as flooring material and surface finish not capable of being ignited and burning and with no combustible materials against the underside. Acceptable materials are those consisting entirely of a combination of steel, iron, brick, tile, concrete, slate, glass or plaster. **Do not** install the heater directly on a combustible wood or carpet floor without placing a noncombustible platform between the floor and the heater.

The boiler can be installed on a combustible floor if a noncombustible base assembly, available from Laars, is used. See the boiler rating plate or the Parts List (Section 11) of this manual for the appropriate base part number. **Boilers must never be installed directly on carpeting.**

As an alternative to the Laars noncombustible base plate, in the United States, the National Fuel Gas Code allows a heater to be placed on a combustible surface when there is a platform under the heater made of hollow masonry no less than 4 inches (102 millimeters [mm]) thick, covered with sheet metal at least 24 gauge thick and extending beyond the full width and depth of the heater by at least 12 inches (305mm) in all directions. The masonry must be laid with ends unsealed, and joints matched to provide free circulation of air from side to side through the masonry (see Figure 4). If the boiler is installed in a carpeted alcove, the entire floor of the alcove must be covered by a noncombustible platform.

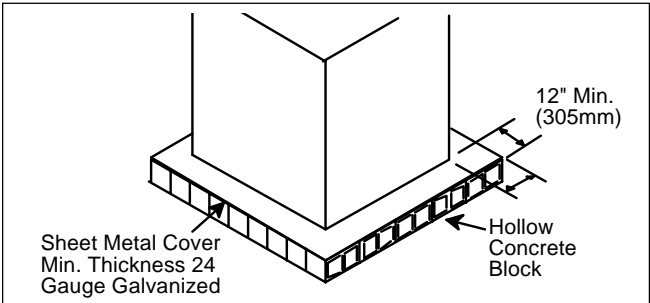

Figure 4. Typical Combustible Floor Installation.

SECTION 3. Venting

3.1 Combustion Air Supply

The boiler location must provide sufficient air supply for proper combustion, and ventilation of the surrounding area as outlined in the latest edition of ANSI standard Z223.1 or in Canada, CSA-B149.1, and any local codes that may be applicable.

In general, these requirements specify that boiler rooms which represent confined spaces should be provided with two permanent air supply openings; one within 12 inches (305mm) of the ceiling, the other within 12 inches (305mm) of the floor (see Table 2).

Boiler Size	Outside Air Area*		Inside Air Area*	
	Sq. In.	sq cm	Sq. In.	sq cm
50	15	97	100	645
75	20	129	100	645
100	25	161	100	645
125	32	206	125	807
160	40	258	160	1032
225	60	387	225	1452

*Area indicated is for one of two openings; one at floor level and one at the ceiling, so the total net free area would be double the figures indicated. For special conditions, refer to NFPA54 ANSI Z223.1. **In Canada refer to the National Standard CSA B149.1 which differs from this table.**
NOTE: Check with louver manufacturers for Net Free Area of louvers. Correct for screen resistance to the Net Free Area if a screen is installed. Check all local codes applicable to combustion air.

**Table 2. Minimum Recommended
Air Supply to Boiler Room.**

Important: See gas piping selection chart, Table 3 for gas line sizing. In all cases, pipe size is larger than inlet connection on heater. Run pipe size shown in chart and reduce at heater inlet.

Outside Air Supply: When combustion air is supplied directly through an outside wall, each opening should have a minimum free area of one square inch per 4,000 BTU/h (1.2kW) input of the total input rating of all appliances in the enclosed area.

If air is provided through horizontal ducts, each opening and duct must provide one square inch of flow area for each 2000 BTU/h (0.6 kW). These requirements are summarized in Table 2. Note that the required size of openings shall be based on the net free area of each opening. Where the free area of louver or grille is known it shall be used in calculating the effective free area. Where the free area are not known, it shall be assumed that wood louvers will have 25 percent free area, and metal louvers and grilles will have 75 percent free area.

Inside Air Supply: When combustion is supplied from inside the building, each opening should have a minimum free area of one square inch per 1,000 BTU/h (0.3kW) input of the total input rating of all appliances in the enclosed area. These openings should never be less than 100 square inches (645 sq. cm).

Note: In Canada, follow Canadian Standard, CSA-B149.1 or local codes.

Exhaust Fans or Vents: Any equipment which exhausts air from the boiler room can deplete the combustion air supply or reverse the natural draft action of the venting system. This could cause flue products to accumulate in the boiler room. Additional air must be supplied to compensate for such exhaust.

The information in Table 2 is not applicable in installations where exhaust fans or blowers of any type are used. Such installations must be designed by qualified engineers.

If a blower or fan is used to supply air to the boiler room, the installer should make sure it does not create drafts which could cause nuisance shutdowns of the pilot. If a blower is necessary to provide adequate combustion air to the boiler, a suitable switch or equivalent must be wired into the boiler control circuit to prevent the boiler from firing unless the blower is operating.

The boiler must be completely isolated and protected from any source of corrosive chemical fumes such as those emitted by trichlorethylene, perchlorethylene, chlorine, etc.

WARNING

Do not store any chemical, cleaners, or other corrosive material near combustion air openings or in the room. Avoid locating dryer vents in the vicinity of combustion air openings. Failure to prevent corrosive materials from mixing with combustion air can result in reduced boiler life and unsafe boiler operation.

AVERTISSEMENT

N'entreposer aucun produit chimique, produit nettoyant ou produit corrosif à proximité des bouches d'air de combustion ou dans la pièce. Éviter de placer des tuyaux de ventilation pour sècheuse à proximité des bouches d'air de combustion. Le fait de laisser des matières corrosives se mélanger à l'air de combustion risque de réduire le cycle de vie de l'appareil de chauffage et de compromettre son fonctionnement.

3.2 Exhaust Venting

Vent piping must be of the same or larger diameter as the vent damper or draft diverter outlet. The only correct procedure for vent pipe sizing is to do so in accordance with Table 3 and the applicable installation code as stated in the following warning.

⚠ WARNING

Vent pipe diameter must be as required by the National fuel Gas Code Z223.1 or the Canadian Installation Codes for Gas Appliances CSA-B149.1. Undersize pipe can result in inadequate venting and oversize pipe can result in vent condensation. In either case the result can be release of combustion products to the indoors. This can cause serious injury or death by carbon monoxide poisoning or asphyxiation.

⚠ AVERTISSEMENT

Le diamètre des tuyaux de ventilation doit répondre aux exigences du *National Fuel Gas Code Z223.1* ou du code canadien des installations des appareils à gaz CSA B149.1. Des tuyaux trop petits risquent d'entraîner une ventilation inadéquate et des tuyaux trop gros risquent de provoquer une condensation dans les tuyaux. Dans un cas comme dans l'autre, des produits de combustion risquent de s'échapper dans le bâtiment et causer des blessures graves ou l'asphyxie par le monoxyde de carbone.

JVS/JVT Size	Vent Pipe Diameter	
	inch	cm
50	4	10
75	5	13
100	5	13
125	6	15
160	6	15
225	7	18

Table 3. Exhaust Vent Connection Size.

3.3 Vent Pipe Sizing and General Installation

All vent installations and boiler stacking must be designed and installed in accordance with all local, state or provincial codes and with:

- Chapter 7, "Venting of Equipment" of the national Fuel Gas Code, ANSI 223.1 latest edition, or the applicable provisions of the local building codes.
- In Canada, CSA-B149.1.

The draft diverter outlet is to be connected to an unobstructed vent pipe of the same or larger diameter, terminating outside the building. The vent pipe must have a listed vent cap and extend at least two feet above any object with a ten foot radius. All connections should be made with rustproof sheet metal screws.

IMPORTANT NOTE: Do not use sheet metal screws at the snap lock joints of Type B gas vents.

Do not weld or fasten the vent pipe to the boiler draft diverter. The weight of the stack must not rest on the boiler. The draft diverter and boiler top must be easily removable for normal boiler service and inspection.

Avoid horizontal runs of the vent pipe, and 90° elbows, reductions and restrictions. Horizontal runs should have at least a 1/4" rise per foot (20mm per meter) in the direction of flow. A vent connector shall be supported for the design and weight of the material employed to maintain clearances and prevent physical damage and separation of joints.

Avoid terminating boiler vents near air conditioning or air supply fans. The fans can pick up exhaust flue products from the boiler and return them inside the building, creating a possible health hazard. Do not located the vent terminal where flue products could strike against building materials and cause degradation.

Always use double-wall or insulated vent pipe when used as a chimney (Type B or equivalent). In cold weather, uninsulated outside vents can chill the rising flue products, blocking the natural draft action of the venting system. This can create a health hazard by spilling flue products into the boiler room. Use engineered venting tables acceptable to the authority having jurisdiction to size the venting pipe or liner.

Avoid oversize vent piping or extremely long runs of the pipe which may cause excessive cooling and condensation.

Before connecting a vent connector to a chimney, the chimney passageway shall be examined to ascertain that it is clear and free of obstructions. When inspection reveals that an existing chimney is not safe for the intended application, it shall be rebuilt to conform to nationally recognized standards (see National Building Code or ANSI/NFPA 211), lined or relined with a suitable liner, or replaced with a vent or chimney suitable for the equipment to be attached.

3.4 Common Venting Systems

3.4.1 Venting Multiple Appliances

When common venting JVS or JVT natural draft boilers with other appliances through one shared duct called a "common vent", special care must be taken by the installer to ensure safe operation. In the event that the common vent is blocked, it is possible, especially for fan-assisted devices, to vent backwards through non-operating appliances sharing the vent, allowing combustion products to infiltrate occupied spaces. **If the appliances are allowed to operate in this condition, serious injury or death may occur.**

⚠ WARNING

Operation of appliances with a blocked common vent may lead to serious injury or death. Safety devices must be implemented to prevent blocked common vent operation. If safe operation of all appliances connected to a common vent cannot be assured, including prevention of spillage of flue gasses into living spaces, common venting should not be applied, and appliances should each be vented separately.

⚠ AVERTISSEMENT

Le fonctionnement des appareils avec un système d'évacuation bloqué peut provoquer des blessures graves, voire la mort. Des dispositifs de sécurité doivent être installés pour éviter le blocage des systèmes d'évacuation. Si le fonctionnement de tous les appareils connectés à un système d'évacuation commun ne peut pas être assuré, y compris la prévention de la dispersion des gaz toxiques dans les espaces habités, on ne devrait pas installer un système d'évacuation commun et chaque appareil devrait être ventilé séparément.

It is for this reason that, in addition to following proper vent sizing, construction and safety requirements from the National Fuel Gas Code, ANSI Z223.1 or in Canada, from CSA B149.1 as well as all applicable local codes, it is required that installers provide some means to prevent operation with a blocked common vent. It is suggested that a blocked vent safety system be employed such that if the switch from one appliance trips due to excessive stack spill or backpressure indicating a blocked vent condition, that all appliances attached to the vent be locked out and prevented from operating. As an additional precaution, it is recommended that a Carbon Monoxide (CO) alarm be installed in all enclosed spaces containing combustion appliances. If assistance is required in determining how a blocked vent safety system should be connected to a LAARS product, please call Applications Engineering at (603) 335-6300.

Refer to the installation and operating instructions on all appliances to be common vented for instructions, warnings, restrictions and safety requirements. If safe operation of all appliances connected to a common vent cannot be assured, including prevention of spillage of flue gasses into living spaces, common venting should not be applied, and appliances should each be vented separately.

3.4.2 Inspection of Commonly Vented Appliances

If the instrumentation of this boiler replaces an older boiler in a common vent system with other appliances, or if you remove additional appliances from the common vent, all the appliances must be checked for proper venting.

At the time of removal of an existing boiler, the following steps shall be followed with each appliance remaining connected to the common venting system placed in operation, while the other appliances remaining connected to the common venting system are not in operation.

1. Seal any unused openings in the common venting system.
Sceller toutes les ouvertures non utilisées du système d'évacuation.
2. Visually inspect the venting system for proper size and horizontal pitch and determine there is no blockage or restriction, leakage, corrosion and other deficiencies which could cause an unsafe condition.
Inspecter de façon visuelle le système d'évacuation pour déterminer la grosseur et l'inclinaison horizontale qui conviennent et s'assurer que le système est exempt d'obstruction, d'étranglement, de fuite, de corrosion et autres défaillances qui pourraient présenter des risques.
3. Insofar as it is practical, close all building doors and windows and all doors between the space in which the appliances remaining connected to the common venting system are located and other spaces of the building. Turn on clothes dryers and any appliance not connected to the common venting system. Turn on any exhaust fans, such as range hoods and bathroom exhausts, so they will operate at maximum speed. Do not operate a summer exhaust fan. Close fireplace dampers.
Dans la mesure du possible, fermer toutes les portes et les fenêtres du bâtiment et toutes les portes entre l'espace où les appareils toujours raccordés au système d'évacuation sont installés et les autres espaces du bâtiment. Mettre en marche les sècheuses, tous les appareils non raccordés au système d'évacuation commun et tous les ventilateurs d'extraction comme les hottes de cuisinière et les ventilateurs des salles de bain. S'assurer que ces ventilateurs fonctionnent à la vitesse maximale. Ne pas faire fonctionner les ventilateurs d'été. Fermer les registres des cheminées.
4. Place in operation the appliance being inspected. Follow the lighting instructions. Adjust thermostat so appliance will operate continuously.
Mettre l'appareil inspecté en marche. Suivre les instructions d'allumage. Régler le thermostat de façon que l'appareil fonctionne de façon continue.
5. Test for spillage at the draft hood relief opening after 5 minutes of main burner operation. Use the

flame of a match or candle, or smoke from a cigarette, cigar or pipe.

Faire fonctionner le brûleur principal pendant 5 min ensuite, déterminer si le coupe-tirage déborde à l'ouverture de décharge. Utiliser la flamme d'une allumette ou d'une chandelle ou la fumée d'une cigarette, d'une cigare ou d'une pipe.

6. After it has been determined that each appliance remaining connected to the common venting system properly vents when tested as outlined above, return doors, windows, exhaust fans, fireplace dampers and any other gas burning appliance to their previous conditions of use.
Une fois qu'il a été déterminé, selon la méthode indiquée ci-dessus, que chaque appareil raccordé au système d'évacuation est mis à l'air libre de façon adéquate. Remettre les portes et les fenêtres, les ventilateurs, les registres de cheminées et les appareils au gaz à leur position originale.
7. Any improper operation of the common venting system should be corrected so the installation conforms with the National Fuel Gas Code, ANSI Z223.1. When resizing any portion of the common venting system, the common venting system should be resized to approach the minimum size as determined using the appropriate tables in Appendix G in the National Fuel Gas Code, ANSI Z223.1.
Tout mauvais fonctionnement du système d'évacuation commun devrait être corrigé de façon que l'installation soit conforme au *National Fuel Gas Code, ANSI Z223.1* et (ou) aux codes d'installation *CSA-B149.1*. Si la grosseur d'une section du système d'évacuation doit être modifiée, le système devrait être modifié pour respecter les valeurs minimales des tableaux pertinents de l'appendice F du *National Fuel Gas Code, ANSI Z223.1* et (ou) des codes d'installation *CSA-B149.1*.

SECTION 4. Gas Connections

4.1 Gas Supply and Piping

Review the following general instructions before continuing the installation.

WARNING

The Mini-Therm II JVS and JVT boilers are designed for use with either natural gas or LP gas. Check the rating plate to be sure that the boiler is designed to use the type of gas being supplied. **DO NOT ATTEMPT TO CONVERT THIS HEATER FOR USE WITH ANY OTHER TYPE OF FUEL.**

AVERTISSEMENT

Les appareils de chauffage à faibles sont conçus pour être utilisés avec du gaz naturel ou du gaz de pétrole liquéfié (GPL). Vérifiez l'information inscrite sur la plaque signalétique du pour vous assurer que l'appareil est conçu pour le type de gaz fourni. **NE PAS ESSAYER DE CONVERTIR CET APPAREIL À UN AUTRE TYPE DE GAZ.**

1. Gas piping installation must be in accordance with the latest edition of ANSI Z223.1 and all local codes. In Canada, the installation must be in accordance with CSA-B149.1 and all local codes that apply.
2. Check the gas supply to be sure that it is the same as the gas indicated on the boiler's plate. Mini-Therm II JVS and JVT boilers, as shipped from the factory, are certified to operate within the altitude range indicated on the rating plate. If a field conversion to a different altitude range should be necessary, conversion parts are available for changing the altitude range of the heater. Refer to Doc. 6079 "Residential Parts Pricing Book" to order the correct part number.

Caution

Permanent damage to the gas valve will occur if the following procedures are not followed.

Attention

Vous endommagerez la soupape de gaz si vous ne respectez pas les procédures suivantes.

3. Use the figures in Table 4 to size the gas inlet piping from the gas meter to the heater. Check all local codes for compliance before installing the heater.

Distance From Gas Meter	Boiler Size					
	50	75	100	125	160	225
	Pipe Size					
0-50' 0-15m	1/2	3/4	3/4	3/4	1	1
50-100' 15-30m	3/4	3/4	3/4	1	1	1-1/4
100-200' 30-60m	3/4	1	1	1	1-1/4	1-1/4

***Note:** These figures are for Natural Gas (.65 Sp. Gr.), and are based on 1/2" water column pressure drop. Check supply pressure with a manometer, and local code requirements for variations. For LPG, reduce pipe diameter one size, but maintain a 1/2" minimum diameter. A 'normal' number of Tees and elbows have been taken into allowance.

Table 4. Natural Gas Pipe Size Requirements*

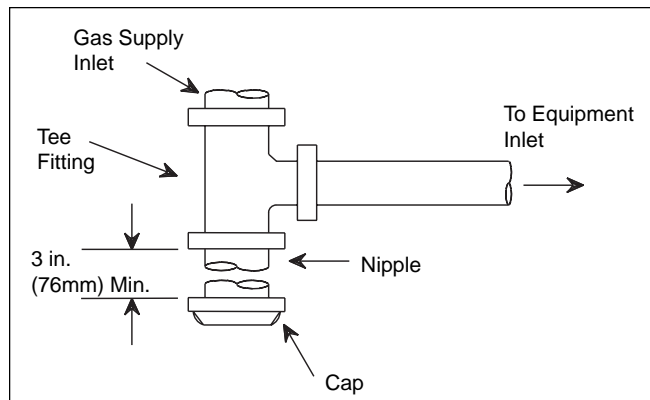

Figure 5. Typical design for a sediment trap/drip leg.

- A sediment trap (drip leg) must be installed ahead of the gas controls (see Figure 5). Fit the trap with a threaded cap which can be removed for cleaning.
- Install a manual gas shutoff valve for service and safety. Do not use a restrictive gas cock. Flexible gas connectors, if used, must be CSA rated for the total input rating of the boiler.
- Disconnect the boiler and its individual shutoff valve from the gas supply system during pressure testing of the system at pressures higher than 1/2 pounds per square inch (psi) (3.45 kilopascals [kPa]). If the test pressure is equal to or less than 1/2 psi (3.45 kPa), close the manual shutoff valve on the heater during the piping pressure test.
- If the gas supply pressure is less than required, check for undersized pipe between the meter and the boiler, a restrictive fitting, or an undersized gas meter. Gas supply pressures to the heater are listed in Table 5.

NOTE: The maximum inlet gas pressure must not exceed the specified value. The minimum value listed is for the purpose of input adjustment. Refer to Table 5.

Supply Pressure	Minimum	Maximum
Natural Gas	5.5 Inches WC (1.3 kPa)	10.5 Inches WC (2.5 kPa)
LP Gas	10.0 Inches WC (2.4 kPa)	13.0 Inches WC (3.1 kPa)

Table 5. Gas Supply Pressure Requirements.

NOTE: The boiler and all other gas appliances sharing the boiler gas supply line must be firing at maximum capacity to properly measure the inlet supply pressure. Low gas pressure could be an indication of an undersize gas meter and/or obstructed gas supply line.

- The correct high fire burner manifold gas pressure is stamped on the rating plate. The regulator is pre-set at the factory, and normally requires no further adjustment. For two-stage units (JVS100-225) be sure unit is able to fire at both high and low fire.
- Before operating the boiler, the complete gas supply system and all connections must be tested for leaks using a leak detector solution. Do not use an open flame.

⚠ Caution

Some leak test solutions (including soap and water) may cause corrosion or stress cracking. Rinse the piping with water after testing.

⚠ Attention

Certaines solutions d'essai d'étanchéité (y compris l'eau et le savon) peuvent causer de la corrosion ou de la fissuration. Rincez les tuyaux à l'eau après l'essai d'étanchéité.

4.2 Special Precautions for LP Gas

LP Gas is heavier than air and can therefore more readily collect or “pool” in enclosed areas if provision for proper ventilation is not made. Be sure to pay special attention to proper ventilation for LP gas. Locate boilers a safe distance from LP gas cylinders and filling equipment. In the United States, consult the “National Fuel Gas Code” (NFPA 54 / ANSI Z223.1, latest edition) or in Canada, the Propane Installation Code (CSA-B149.1), any local codes and fire protection authorities about specific installation restrictions in your area.

SECTION 5. Water Connections

5.1 Water Piping

Figure 6 shows 'typical' plumbing installations. Be sure to provide unions and isolation valves at the boiler inlet and outlet so it can be isolated for service. Check local codes for specific plumbing requirements before beginning the installation.

An ASME pressure relief valve is supplied on all JV boilers, and is pre-set at 30 PSI. The valve outlet piping must discharge to a drain. Under no circumstances should the relief valve piping be a closed circuit.

A pressure reducing valve (automatic feed) must be used to maintain system at constant proper pressure (see Figure 6). Supply properly installed purge valves to eliminate air from each circuit.

A drain valve is supplied with the boiler, and can be found in the plastic bag shipped with each boiler. This valve is to be installed on the lower right side of the boiler, see Figure 1, and is used for draining the unit. **To drain the boiler completely, open the drain valve and remove the two drain plugs located on the lower left side of the boiler.**

Be sure to include air vent devices located at the highest point in the system to eliminate trapped air, and an air elimination device near the outlet side of the JV boiler. Manual vent valves are recommended.

Hot water piping should be supported by suitable hangers or floor stands, NOT by the boiler. Due to expansion and contraction of copper pipe, consideration should be given to the type of hangers used. Rigid hangers could transmit noise through the system caused by the piping sliding in the hangers. It is recommended that padding be used when rigid hangers are installed.

Gas piping should also be supported by suitable hangers or floor stands, not the boiler.

A properly sized expansion tank must be included in the system. Laars offers an aircharged diaphragm-type expansion tank, with an automatic feed valve, which includes a pressure regulator set at 12 psig. **The part numbers are:**

Less Than 20 Gallons in System	A0066800
20 to 45 Gallons in System	A0066900

5.1.1 By-pass Piping

The following information and suggestions are made on by-pass piping as it affects the temperature rise at the boiler. A boiler temperature rise must be taken on all JV boiler installations. If the temperature rise exceeds 30°F (17°C) at full rate, it is an indication that the boiler is not receiving adequate water flow. Check the pump for any obstruction, replace the pump with a larger size where necessary, or install a system by-pass as indicated in Figures 6 and 7.

A full sized, 1¼" bypass with balancing valves is strongly recommended for all systems, and required when: 1) the boiler is installed without primary-secondary piping in a multiple zone system; 2) when the return water temperature can be expected to be lower than 120°F (44°C); or 3) whenever the system piping on the outlet side of the boiler may allow reduced flow through the heat exchanger, causing excessive temperature rise (see Section 5.2).

Note: Laars strongly recommends a primary/secondary piping system for all installations, especially sizes 125, 160 and 225. In this system, a circulator is dedicated to pumping the boiler only. This circulator should be sized for the boiler head loss and flow rate.

All precautions must be taken by the installer to insure that a maximum temperature rise through the boiler does not exceed 30°F (17°C). The temperature rise on boilers installed in multi-zone systems using zone valves must be taken when the zone of the longest length and/or the zone of the highest head loss is open.

A full size, 1¼" diameter by-pass with balancing valve must be installed if a return water temperature below 120°F (44°C) is expected under operating conditions regardless of boiler size. This may be expected in many systems, including in-floor radiant and snow melt systems.

Adjusting the bypass:

Refer to figure 7. Provide a means of measuring temperature on the inlet pipe to the boiler such as using a strap on or infrared thermometer. Starting with both balancing valves fully open, start the boiler. Adjust the balancing valve on the return to the system slowly to provide 120°F (44°C) water at the inlet to the boiler, leaving the bypass balancing valve fully open. As the system warms up, this valve may need to be adjusted open. In rare cases, this valve will have to be kept fully open, and the bypass balancing valve adjusted toward closed to prevent heated bypass water from satisfying the call for heat when the system is up to temperature.

5.2 Alternate Auto-Bypass Operation

Use of the Laars thermostatic union, p/n 2400-030, can provide automatic bypass operation in primary - secondary piped systems (but cannot be used when primary - secondary piping is not used). The thermostatic union is installed on the outlet piping, after the bypass assembly. It can be used in place of a balancing valve. It opens fully at 140°F (see Figure 6). Contact the factory for more information.

The preferred piping configuration for JV boilers is always using primary/secondary piping. There are some applications that are acceptable without primary/secondary piping, see below.

LOW TEMP SYSTEMS

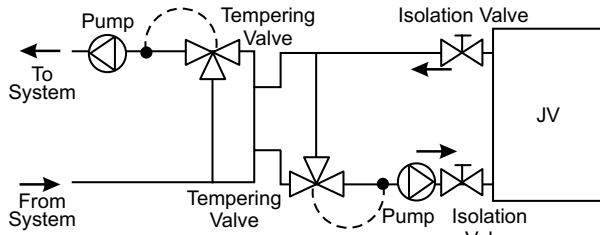

Primary/Secondary System Loop with Tempering Valve and Pump with Boiler Loop with Tempering Valve and Pump

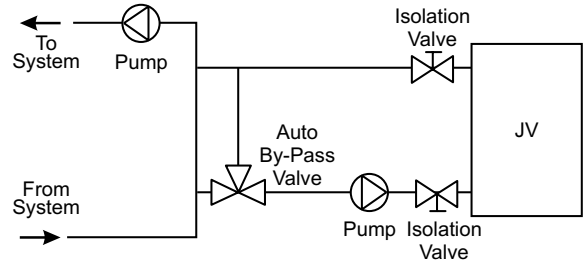

Primary/Secondary Piping with Automatic By-Pass

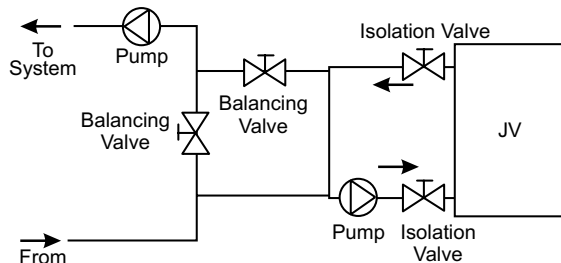

Primary/Secondary Piping with Field Balancing (for Fixed Low Return Temperatures)

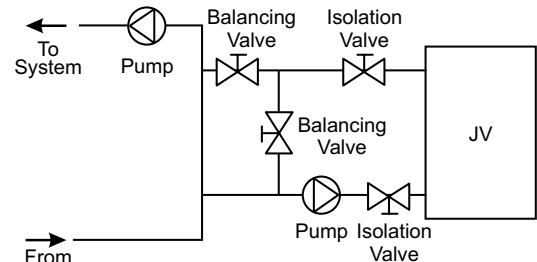

Primary/Secondary Piping with By-Pass (for Fixed Low Return Temperatures)

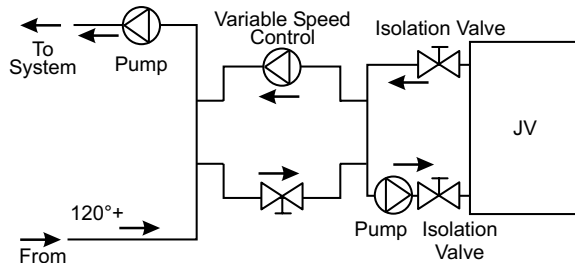

Primary/Secondary Piping with Variable Speed Injection

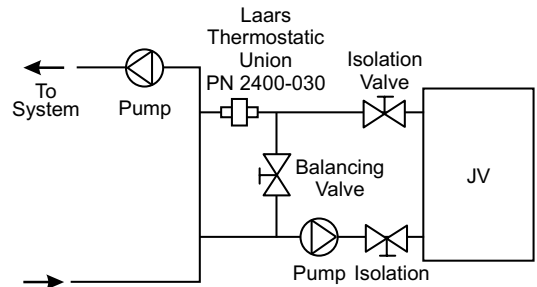

Primary/Secondary Piping with Laars Thermostatic Union as an Automatic Bypass

NON-LOW TEMPERATURE SYSTEMS (120°F+ Return Temps)

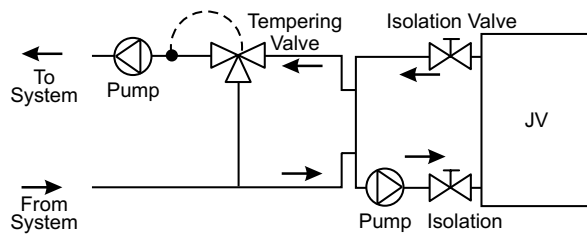

Tempering Valve with System Loop and Boiler Loop Pump

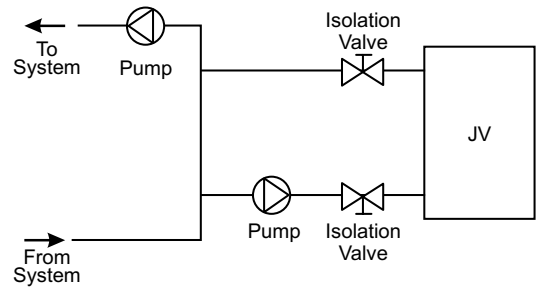

Simple Primary/Secondary Piping - Hydronic - Not Low Temp

NOTE: All closed loop systems should include air elimination, expansion tank and feed water inlet. Place at point of lowest pressure (typically at the inlet of pump).
 NOTE: Ball valves should not be used as balancing valves. Only use for shutoff apps.

Figure 6. Typical Plumbing Installations.

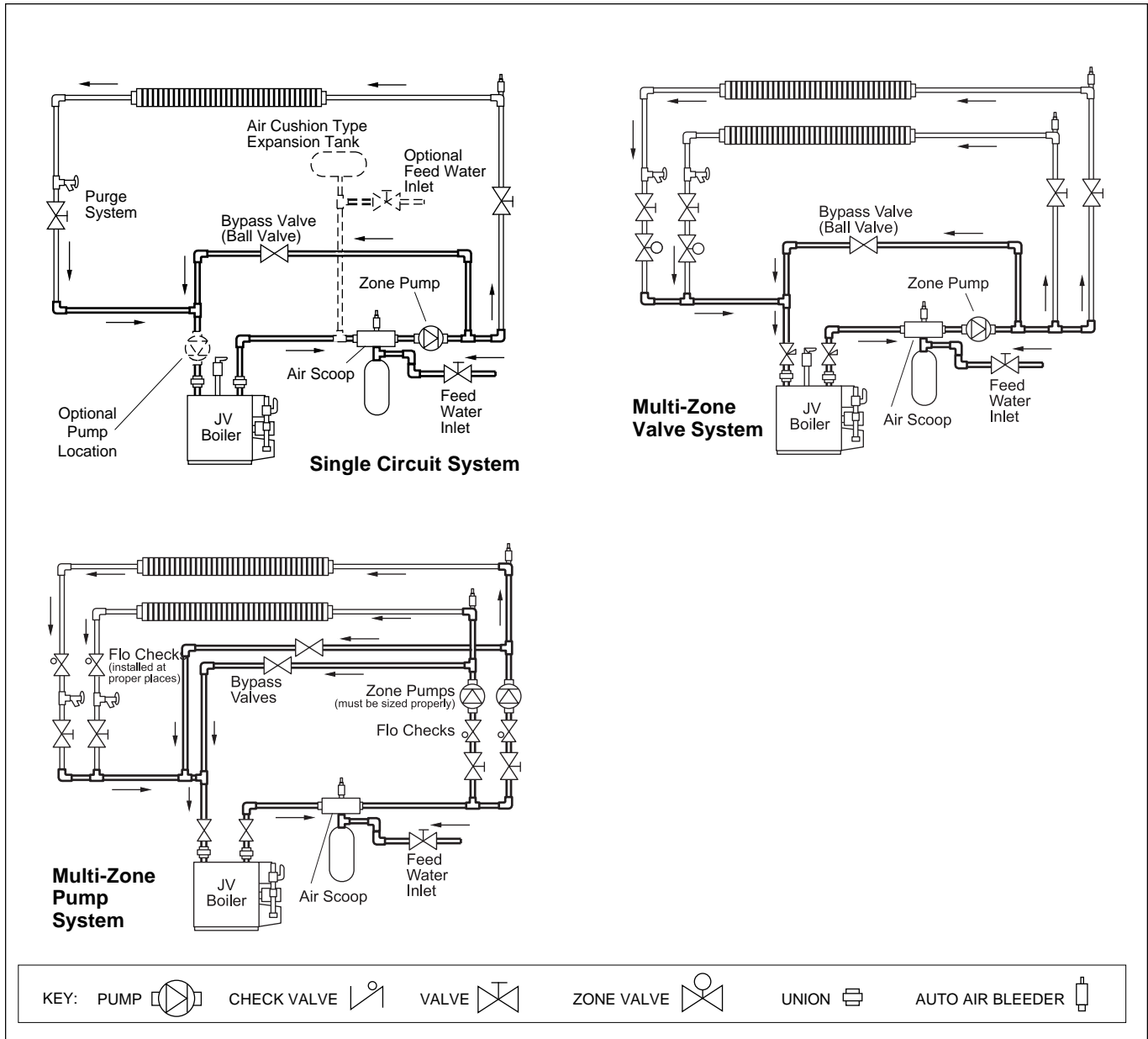

Figure 6A. Typical Plumbing Installations.

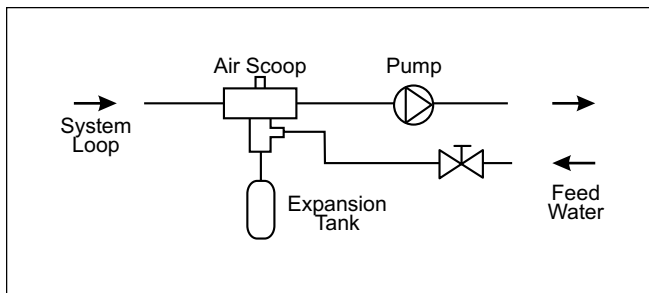

Figure 6B. Typical Plumbing Installations.

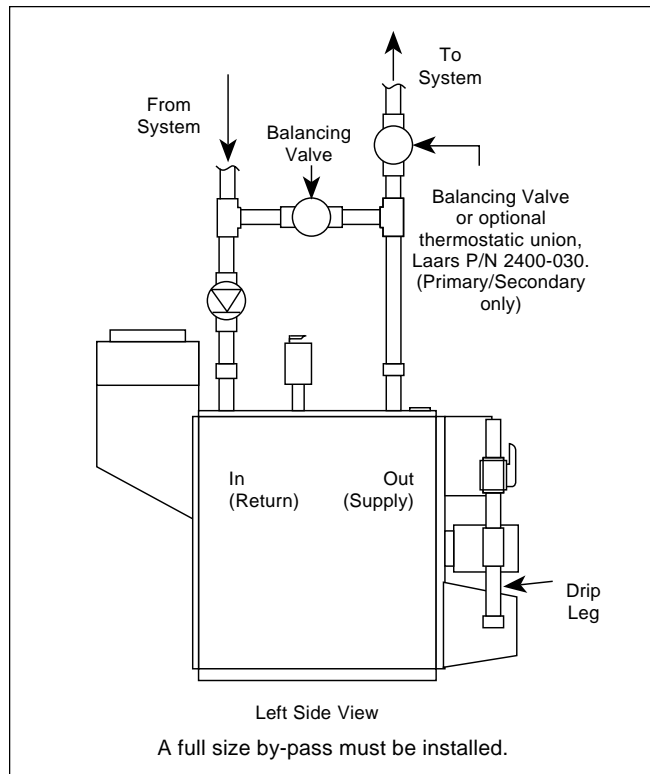

Figure 7. By-pass Piping.

5.3 Flow Requirements

All high recovery, low volume water boilers must have adequate flow for efficient operation. Pump selection is critical to this goal, and pumps should be selected to provide for system design water temperature rise. Table 6 details temperature rise and water flow (GPM) for the Mini-Therm boilers.

Damage from improper flow is not warranted.

Failure to insure proper water flow through the heat exchanger of the boiler will void the Laars warranty. Flow can be verified by measuring the difference in water temperatures between the boiler inlet and outlet. For example: For a JV-100

installation, the inlet water temperature is 160°F (71°C), and the outlet temperature is 180°F (82°C) at Normal Input Rate from the rating plate. That means there is a 20° (11°C) temperature rise through the boiler. According to Table 1, that would indicate a flow rate of 8 GPM (0.5L/S). Temperature rise must be measured with the longest (highest head) zone calling for heat alone.

Other factors to be considered before selecting a pump are pipe size, the number of fittings throughout the system, smoothness of the interior surface of the pipe, the quantity of water flowing through the pipe, whether a glycol solution is being used, and the total length of piping in the system. Table 7 provides example pump selection criteria using Type L copper piping, one zone valve and up to eight elbows for single zone systems. Consult the factory or a qualified system designer if you have more fittings, different size or type of pipe (especially in retrofit situations), or some other unique system configuration not illustrated in this manual.

Size	1/2" Pipe		3/4" Pipe			1" Pipe			1-1/4" Pipe		
	Pump H.P.		Pump H.P.		Pump H.P.	Pump H.P.		Pump H.P.		Pump H.P.	
	1/25	1/12	1/25	1/12	1/6	1/25	1/12	1/6	1/25	1/12	1/6
50	50	99	390	680	*	*	*	*	*	*	*
75	*	35	160	300	460	640	*	*	*	*	*
100	*	*	77	150	260	330	620	*	*	*	*
125	*	*	27	80	140	170	360	600	*	*	*
160	*	*	*	25	72	57	160	330	190	480	*
225	*	*	*	*	*	*	*	110	*	69	330

*A circulator and/or primary/secondary piping are required. Consult factory.

1. Chart is based on 30°F (17°C) maximum temperature rise.
2. Calculations are based on Type L copper tubing with one zone valve and eight elbows.
3. Typical circulating pumps: 1/25 HP=Taco 007, B&G LR-20 or SLC-25, Grundfos UP15-42F, or equivalent. 1/12 HP=B&G LR-12, Grundfos UP26-42F, or equivalent. 1/6 HP=B&G series HV, Grundfos UP43-75, or equivalent.

Table 7. Maximum Suggested Circuit Length in Feet.

Size	15°F 8°C				20°F 11°C				25°F 14°C			
	Flow Rate		Headloss		Flow Rate		Headloss		Flow Rate		Headloss	
	gpm	l/s	ft	m	gpm	l/s	ft	m	gpm	l/s	ft	m
50	5.3	0.3	0.3	0.1	4.0	0.3	0.2	0.1	3.2	0.2	0.1	0.0
75	8.0	0.5	0.6	0.2	6.0	0.4	0.3	0.1	4.8	0.3	0.2	0.1
100	10.7	0.7	1.3	0.4	8.0	0.5	0.7	0.2	6.4	0.4	0.5	0.2
125	13.3	0.8	2.2	0.7	10.0	0.6	1.3	0.4	8.0	0.5	0.8	0.2
160	17.0	1.1	2.5	0.8	12.8	0.8	1.8	0.5	10.2	0.6	1.2	0.4
225	24.0	1.5	5.0	1.5	18.0	1.1	3.1	0.9	14.4	0.9	1.9	0.6

gpm = Water Flow in gallons per minute. l/s = Water flow in liters per second.
 ft = Pressure drop (headloss) through the boiler in feet of water. m = Pressure drop (headloss) through the boiler in meters of water.
 Notes: 1. Shaded area is the recommended flow and temperature rise.
 2. Temperature rise and associated flow rates are based on high fire operation at the Normal Input Rate from the rating plate.

Table 6. Temperature Rise °F °C.

5.4 Chilled Water Systems

If the boiler is installed in conjunction with refrigeration systems, it shall be installed so that the chilled medium is piped in parallel with the heating boiler with appropriate valves to prevent the chilled medium from entering the heating boiler.

When boiler piping is connected to heating coils, which are in close proximity to refrigerated air circulation, there must be flow control valves or other automatic methods to prevent gravity circulation of the boiler water during the cooling cycle.

5.5 Oxygen Permeable Systems

The JV boiler must not be direct connected to a heating system utilizing oxygen permeable tubing. Provide a water-to-water heat exchanger between systems to prevent corrosion of ferrous metals such as the boiler's piping wet walls, etc. Air elimination devices are not sufficient protection, and corrosion damage is not covered under the limited warranty.

5.6 Anti-Freeze

Non-toxic heating system anti-freeze may be added to the hydronic system provided the concentration does not exceed 50%, and the anti-freeze contains an anti foamant. Follow the anti-freeze manufacturer's recommendations for yearly or biannual replacement of system anti-freeze.

SECTION 6. Electrical

⚠ WARNING

ELECTRICAL SHOCK HAZARD. This boiler contains wiring that carries high voltage. Contact with these wires may result in severe injury or death.

⚠ AVERTISSEMENT

POSSIBILITÉ DE CHOCS ÉLECTRIQUES. Ce système de chauffage contient du filage de haut voltage. Un contact avec ces fils peut résulter en des blessures sérieuses ou la mort.

⚠ Caution

Label all wires prior to disconnection when servicing controls. Wiring errors can cause improper and dangerous operation. Verify proper operation after servicing.

⚠ Attention

Au moment de l'entretien des commandes, étiquetez tous les fils avant de les débrancher. Des erreurs de câblage peuvent entraîner un fonctionnement inadéquat et dangereux.

6.1 General Information

Wiring connections must be made exactly as shown in the wiring diagram found on the inside of the control box cover (see Figure 8). The boiler must include a definite means of grounding. There is a bonding lug, where a bond wire must be attached.

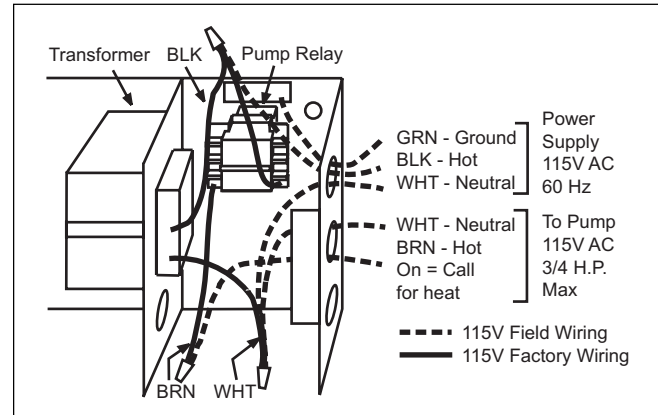

Figure 8. Field Wiring Connections.

6.2 Main Power

Electrical wiring must be in accordance with the latest edition of the National Electric Code (NEC), ANSI/National Fire Protection Association (NFPA) 70, unless local code requirements indicate otherwise.

The heater comes factory-wired intended for use with 115 Volt, 60 Hz AC field electrical supply.

Making electrical connections must be done by a certified electrician only, as with all wiring. Be sure that the power source to the heater is turned off or disconnected before servicing.

To wire the Mini-Therm II boiler to a 115V / 60 Hertz (Hz) electrical source:

1. Remove the two screws attaching the front cover of the control box.
2. There are four wires coiled in the area on the right side of the control box, supplied with wire nuts: 2 black wires twisted together, a white wire and a brown wire (see Figure 8).
3. Follow the schematics in Figure 9. Remove the wire nut from the two black wires, and connect the hot lead from a 115V power supply to both wires. Secure the three wires with the wire nut. The white, neutral wire should be joined to the other neutral lead coming from the 115V power supply, and the neutral lead coming from the pump. The brown wire attaches to the hot side of the pump.
NOTE: No external junction box is required.
4. Attach the leads from the wall thermostat to the R and W terminals on the terminal strip, located on the left side of the control box.

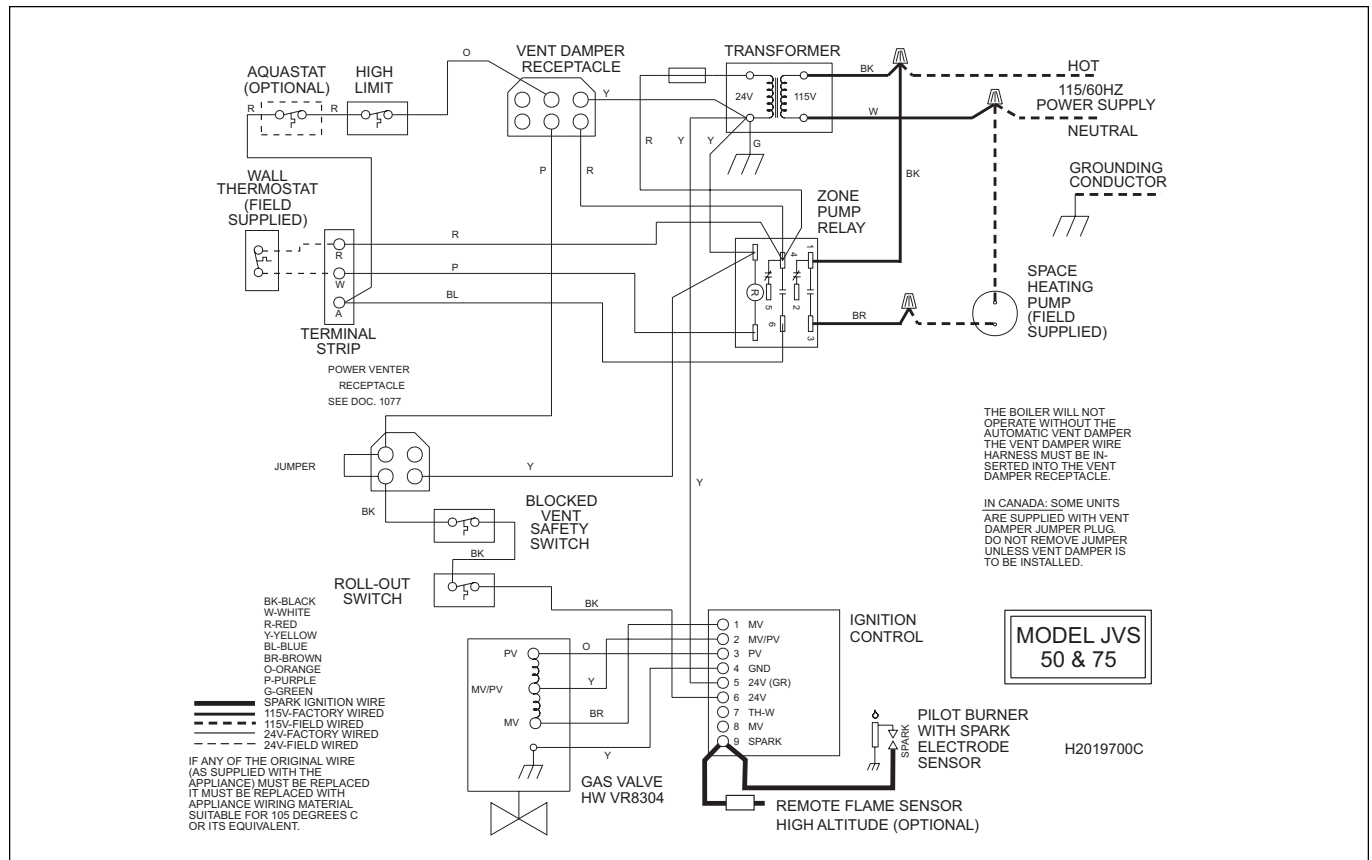

Figure 9a. Wiring Diagram, Spark Ignition System (JVS 50 & 75).

5. When using a Laars or field supplied power venter, the proving switch must be connected in series with the hi-limit. See wiring diagrams, Document 1077. See Figure 1 for vent damper connections.
6. Check the boiler wiring and pump for correct voltage, frequency and phase. If the pump circuit is other than 115V, be sure there is an appropriate transformer or relay installed. The pump relay is suitable for pumps of ¾ HP or less.
7. For systems with multiple zone pumps or valves, see Figure 10.
A means of disconnecting the electrical supply must be provided within sight of the boiler. The pump and boiler must be wired as shown to insure that the pump is running whenever the boiler is firing.

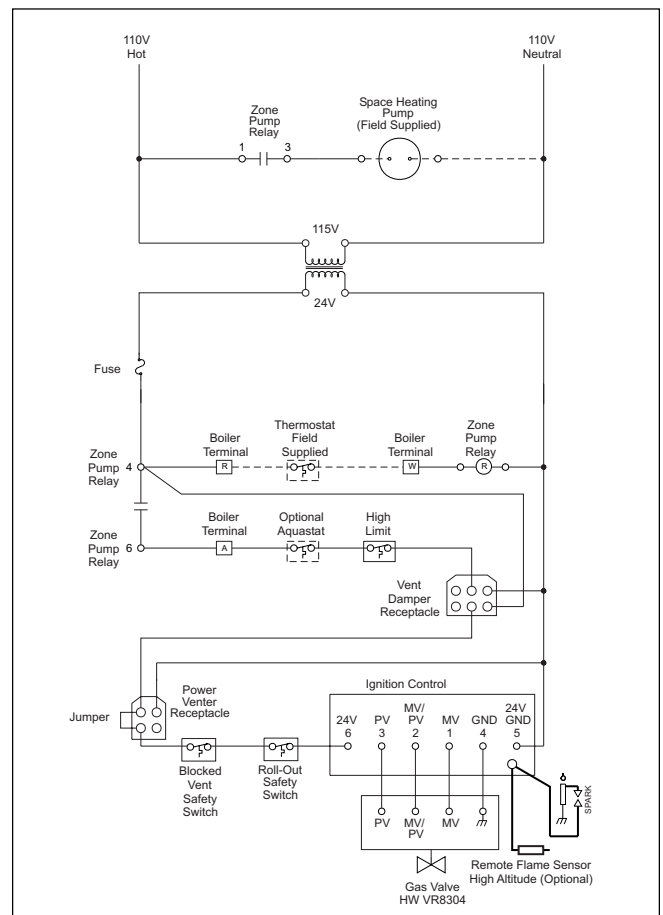

Figure 9b. Schematic, Spark Ignition System (JVS 50 & 75).

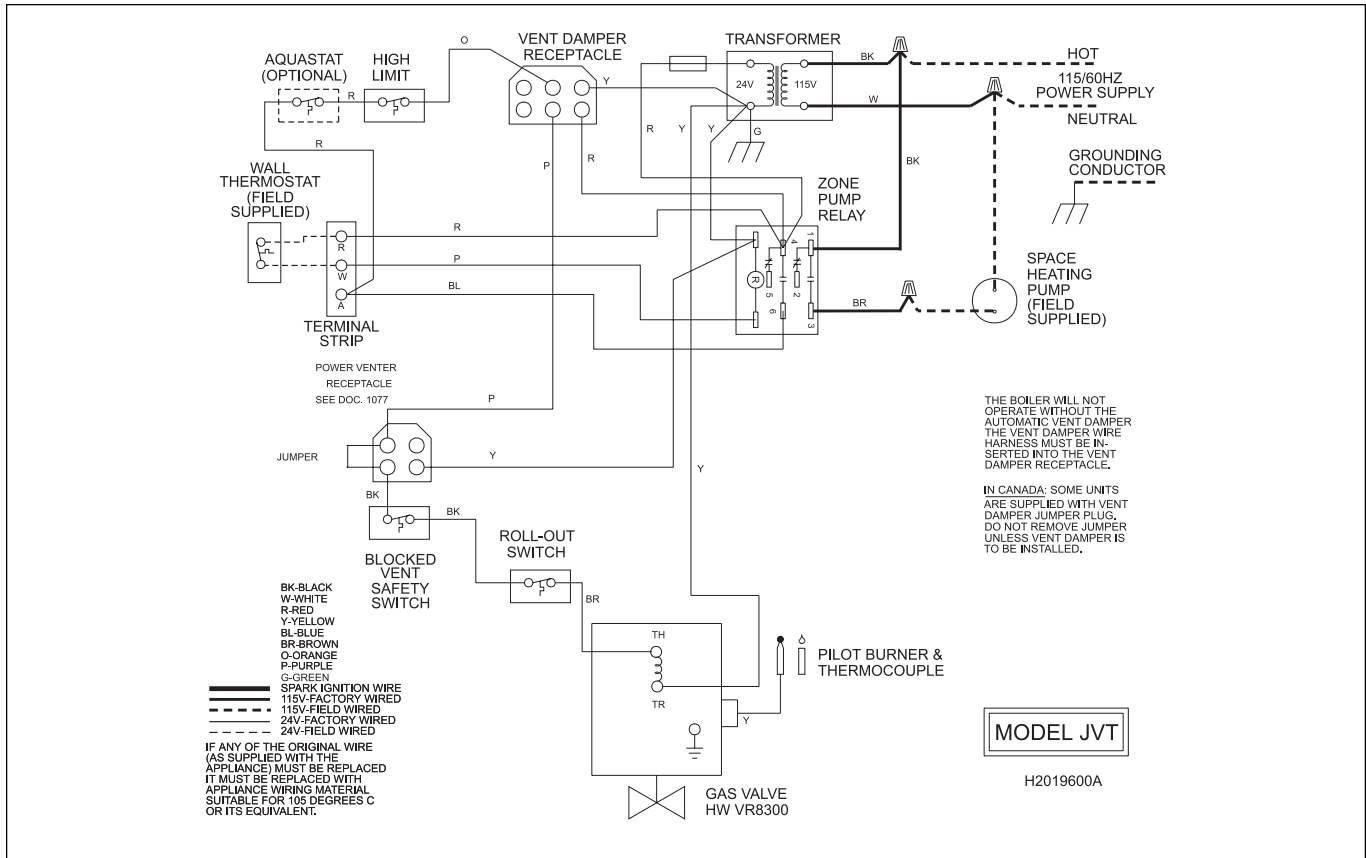

Figure 9c. Wiring Diagram, Standing Pilot System (JVT).

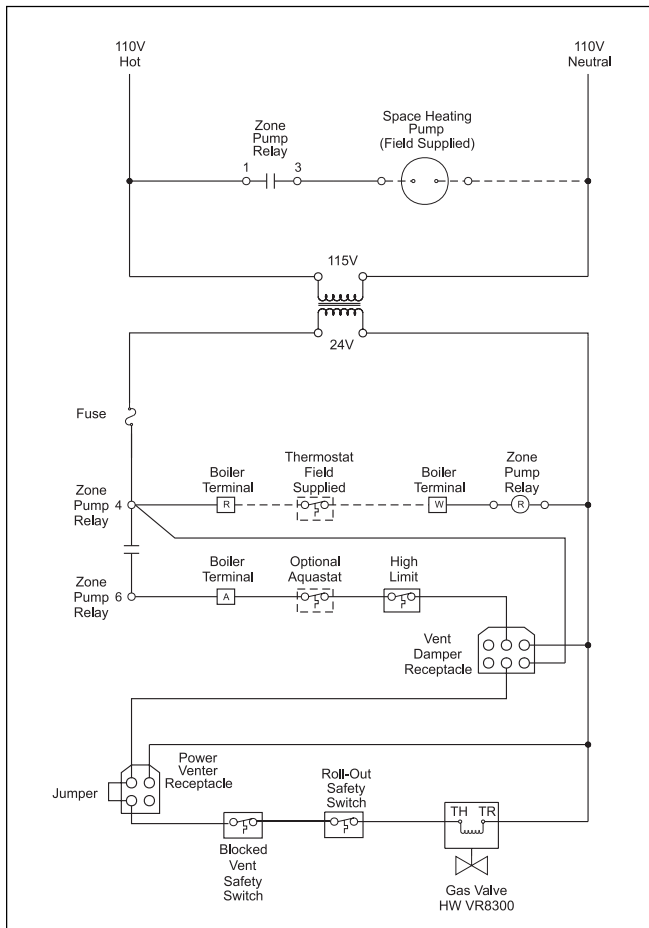

Figure 9d. Schematic, Standing Pilot System (JVT).

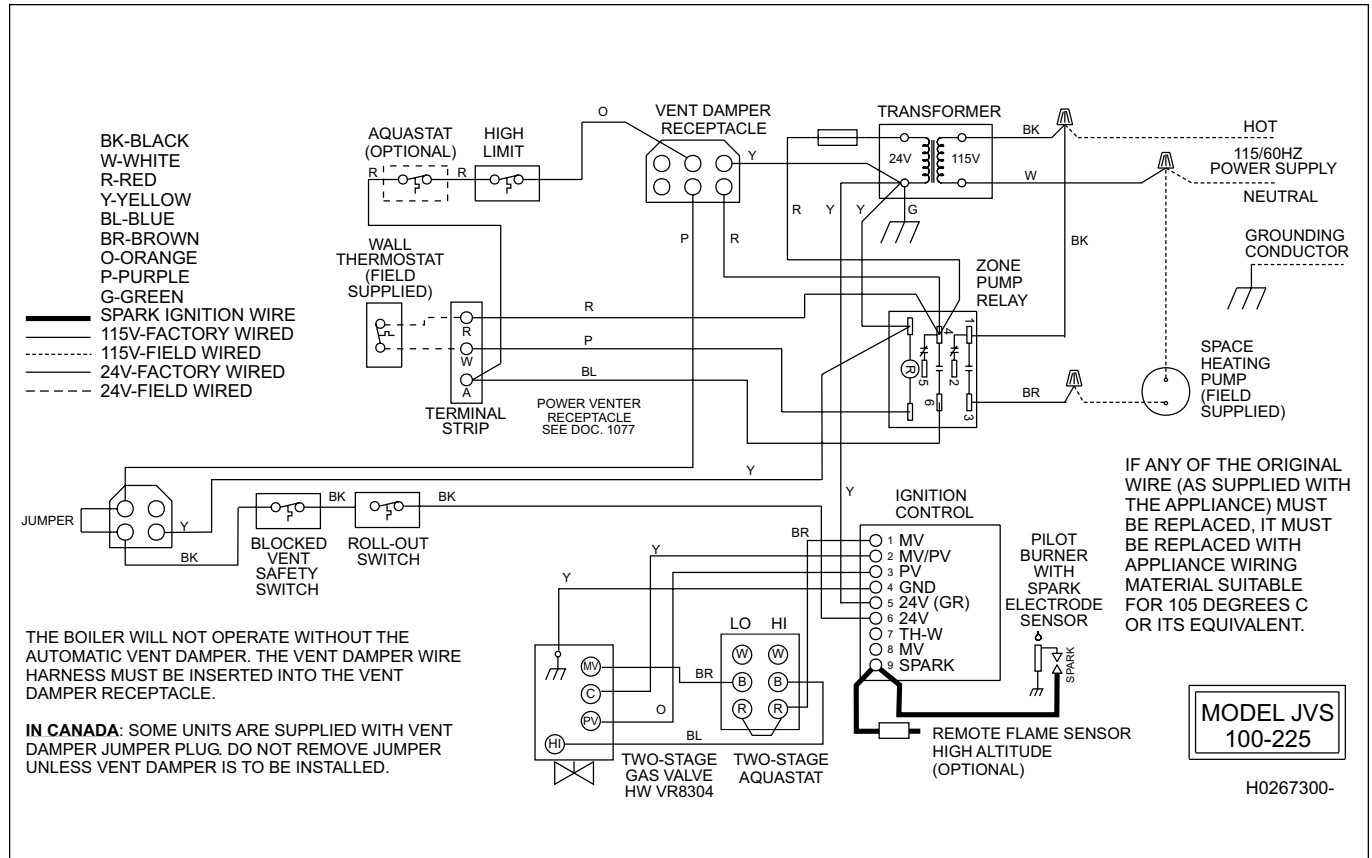

Figure 9e. Wiring Diagram, Spark Ignition, Two-Stage (JVS 100-225).

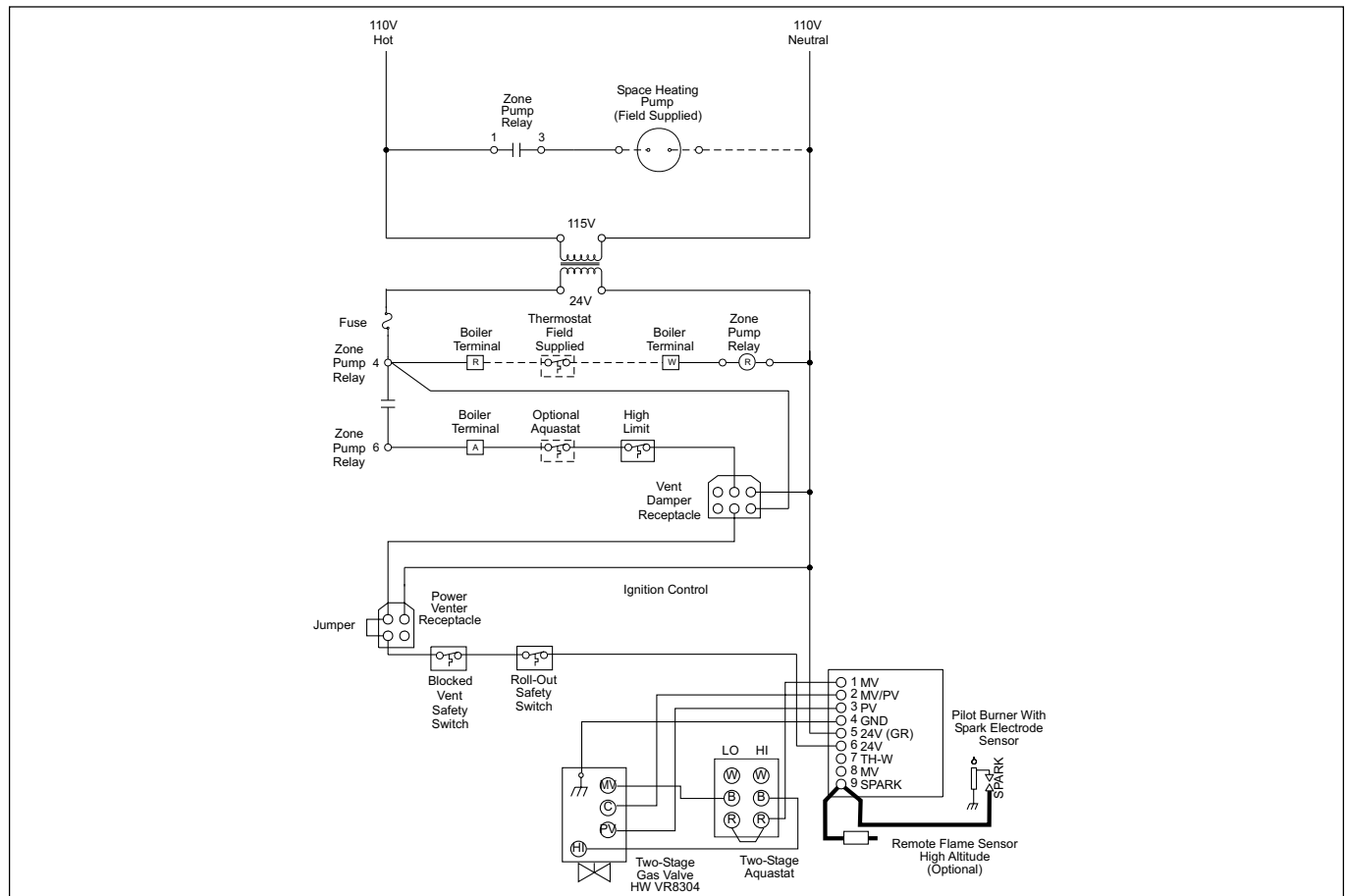

Figure 9f. Schematic, Two-Stage (JVS 100-225).

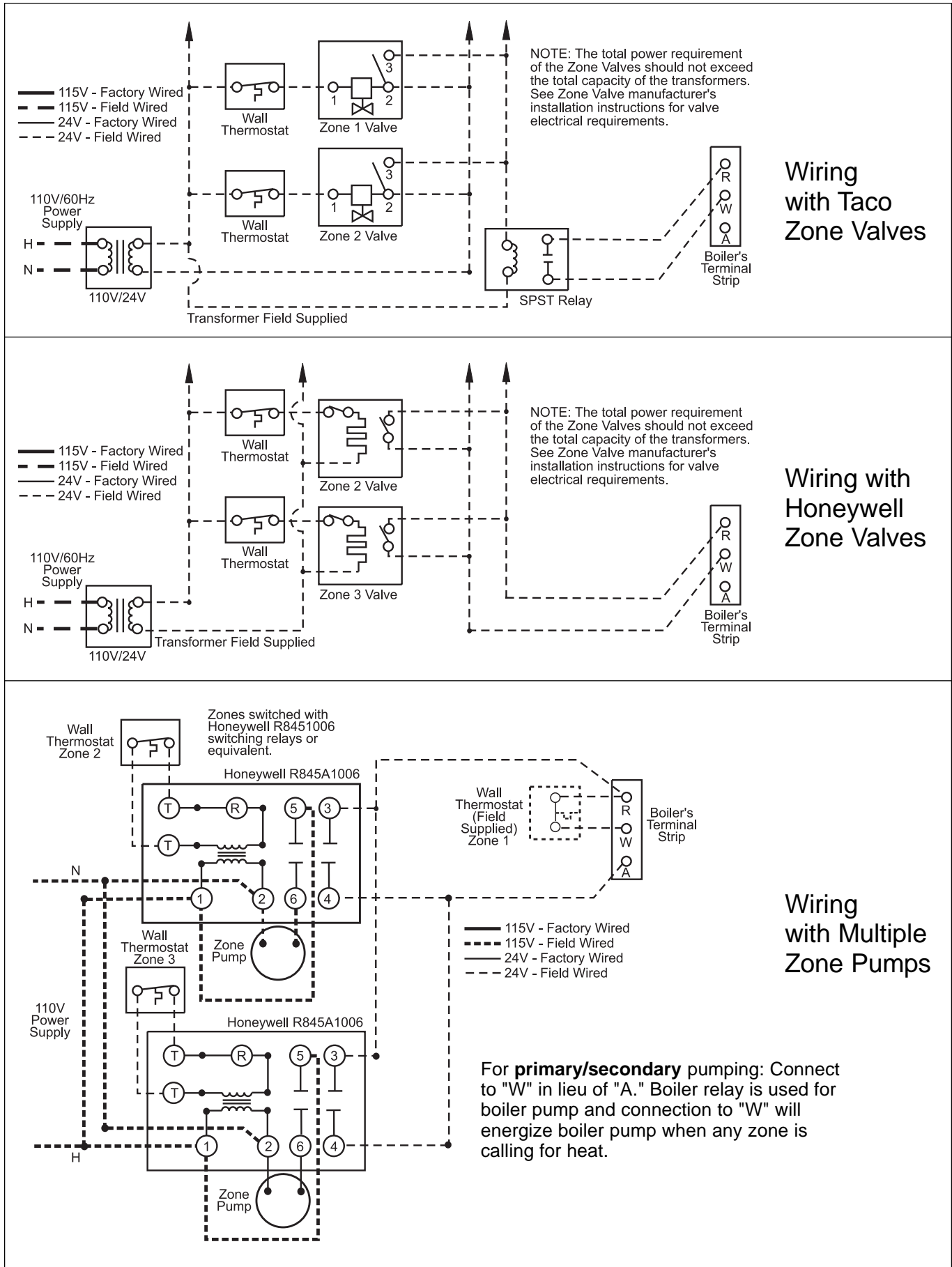

Figure 10. Multiple Zone Wiring.

6.3 Grounding

⚠ WARNING

The boiler must be electrically grounded in accordance with the requirements of the authority having jurisdiction or, in the absence of such requirements, with the latest edition of the National Electrical Code, ANSI/NFPA 70, in the U.S. and with latest edition of CSA C22.1 Canadian Electrical Code, Part 1, in Canada. Do not rely on the gas or water piping to ground the metal parts of the boiler. Plastic pipe or dielectric unions may isolate the boiler electrically. Service and maintenance personnel who work on or around the boiler may be standing on wet floors and could be electrocuted by an ungrounded boiler.

⚠ AVERTISSEMENT

La chaudière doit être mise à la terre selon les exigences officielles locales ou, en l'absence de toute instruction officielle, l'installation doit être conforme au National Electrical Code, ANSI/NFPA 70, aux États-Unis et avec la dernière édition du Code électrique canadien CSA C22.1, Partie 1, au Canada. N'utilisez pas la tuyauterie de gaz ou d'eau pour mettre à la terre les parties métalliques de la chaudière. Les unions diélectriques ou avec tuyau en plastique peuvent isoler la chaudière électriquement. Les membres du personnel de service et d'entretien qui travaillent sur et autour de la chaudière peuvent marcher sur des planchers mouillés et pourraient se faire électrocuter par une chaudière non mise à la terre.

6.4 Auxiliary Devices

6.4.1 Flow Switch

If the system includes a flow switch, it should be wired in series with the high-limit switch. The boiler will not fire unless the pump is running and the flow switch is closed.

Field installed safety devices and operating controllers, such as a valve end switch, draft switches, relays, timers, and outdoor temperature reset devices, can be connected to the boiler through the wall thermostat circuit. Do not exceed a draw of 30VA on the transformer secondary.

6.4.2 Heat Anticipator

For single zone installations, the wall thermostat heat anticipator should be set at 0.5 amperes. For multi-zone installations, have a qualified electrical technician make the necessary measurements to properly set the thermostats.

SECTION 7. Operating Instructions

7.1 Normal Operation

The Laars Mini-Therm II JVS and JVT boilers are capable of automatic operation based on a call for heat at present temperatures. The boiler has an internal safety system which allows operation in a variety of conditions and prevents operation when certain adverse conditions are encountered.

When the wall thermostat calls for heat and the boiler is powered, an operating cycle is initiated. (On continuous pilot ignition models (JVT) the pilot must also be lit). The pump relay turns on the pump, the damper activator rotates the damper blade to the open position and the indicator light comes on.

On spark ignition models (JVS 50-75), if the water temperature is below the limit setting, the ignition module lights the pilot and checks the flame existence. After the pilot is proven to be lit, the ignition module opens the main gas valve and the main burners ignite.

On 2-Stage spark ignition models (JVS 100-225), if the water temperature is below the limit setting, the ignition module lights the pilot and checks the flame existence. After the pilot is proven to be lit, the ignition module opens the main gas valve and the main burners ignite. The main gas valve is controlled by the two-stage operating control (see Figure 11) and will cycle between high, low and off as the load demands.

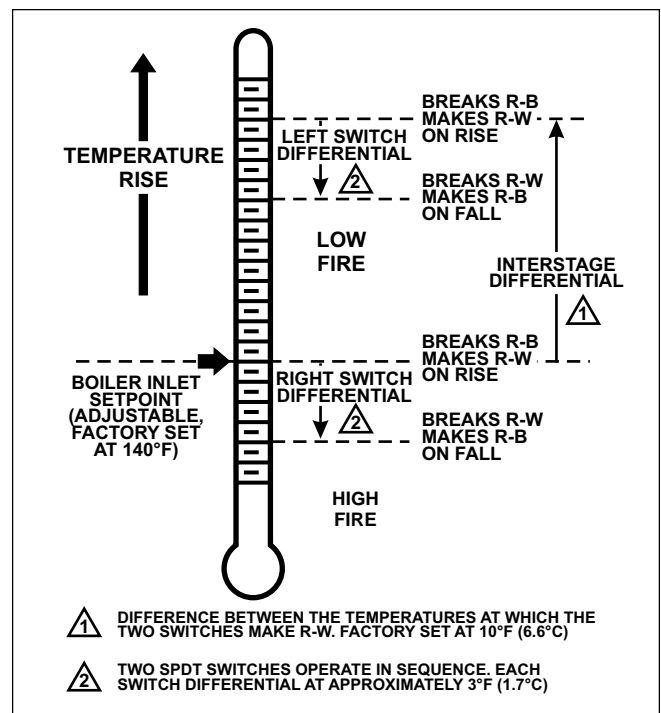

Figure 11. L6008G Operation.

On continuous pilot ignition models (JVT), if the water temperature is below the limit setting, the ignition module opens the main gas valve, and the main burners ignite.

Operation will continue on all ignition systems until either the wall setting thermostat is satisfied or the high-limit thermostat opens. The burners and pilot (on JVS models) shut-off and the pump relay turns off the pump. The damper activator rotates the damper blade to the closed position and the indicator light goes off.

When the room temperature falls below the wall thermostat setting, the cycle repeats.

Note: When equipped with a pump delay option, the pump runs for a short time after the burners turn off and the damper closes.

7.2 Start-up

7.2.1 Filling the System

NOTE: It is strongly recommended that the system be cleaned and flushed to remove scale, oil, paste, flux, etc., before the system is filled.

It is **crucial** to the efficient operation of the system that all air be removed from the circuit. For this reason, an air scoop and vent should be located close to the boiler outlet, and there should be a minimum distance between cold water feed and system purge valve.

1. When the system has been completely installed, close all air vents and open the makeup water valve. Allow the circuit to fill slowly.
2. Adjust the pressure to provide a minimum of 12 psi (82.7kPa) at the highest point in the circuit. If a pressure regulator is also installed in the line, adjust it to the same pressure.
3. Close all gate valves. Purge one circuit at a time as follows:
 - a. Open one circuit drain valve and let water drain out for at least 5 minutes. Be certain there are no air bubbles visible in the water stream before closing the drain valve.
 - b. Repeat this procedure for each circuit.
4. Open all gate valves after all circuits have been purged.
5. Run the system circulating pump for a minimum of 30 minutes with the boiler shut off.
6. Open all strainers in the system, and check for debris.
7. Recheck all air vents as described in Step 3 above.
8. Some expansion tanks require visual inspection of liquid level. If necessary, inspect the liquid level in the expansion tank. With the system full of water, and under normal operating pressure, to ensure proper water level in the expansion tank.
9. Start up boiler according to the procedures described in Section 7 and operate the system,

including the pump, boiler, and radiation units, for one hour.

10. Recheck the water level in the expansion tank, if necessary. If it exceeds $\frac{1}{2}$ of the volume of the tank, open the tank drain and reduce the water level.
11. Shut down the entire system, and vent all radiation units and high points in the system.
12. Close the water makeup valve and check the strainer in the pressure reducing valve for sediment or debris. Reopen the water makeup valve.
13. Verify system pressure with the boiler pressure gauge before beginning regular operation.
14. Within 3 days of start-up, recheck and bleed all air vents and the expansion tank using these instructions.
15. In systems piped with cross-linked polyethylene tubing (PEX) it is essential that all air is purged from all zones in the system to prevent PEX tubing failure.

7.2.2 Boiler Start-up

WARNING

For your safety, when starting the boiler, keep your head and face well away from the burner area to prevent any risk of personal injury.

AVERTISSEMENT

Pour votre sécurité personnelle lorsque vous mettez l'appareil en marche, tenez votre tête et votre visage loin du brûleur pour éviter tout risque de blessure.

WARNING

Vent pipes, and heater tops get hot! These surfaces can cause serious burns. Do not touch these surfaces while the heater is in operation.

AVERTISSEMENT

Les tuyaux d'aération et le dessus de l'appareil deviennent chauds! Ils peuvent causer de graves brûlures. Ne touchez pas à ces surfaces lorsque l'appareil est en marche.

Caution

Do not use this boiler if any part has been under water. Immediately call a qualified service technician to inspect the heater and replace any part of the control system and any gas control which has been under water.

Attention

N'utilisez pas cet appareil s'il a été plongé dans l'eau, même partiellement. Faites inspecter l'appareil par un technicien qualifié et remplacez toute partie du système de contrôle et toute commande qui ont été plongés dans l'eau.

⚠ Caution

Should overheating occur or the gas supply fail to shut off, do not turn off or disconnect the electrical supply to the pump. Instead, shut off the gas supply at a location external to the appliance.

⚠ Attention

En cas de surchauffe ou si l'admission de gaz ne peut être coupée, ne pas couper ni débrancher l'alimentation électrique de la pompe. Fermer plutôt le robinet d'admission de gaz à l'extérieur de l'appareil.

⚠ Caution

Do not attempt repairs on the gas controls or appliance. Tampering is dangerous and voids all warranties.

⚠ Attention

Ne tentez pas d'effectuer des réparations au système de régulation du débit du gaz ou à l'appareil. Toute modification non autorisée est dangereuse et entraîne l'annulation de toutes les garanties.

⚠ Caution

Keep all objects off the top of the boiler. Blocking air flow could damage the heater, and may void the warranty.

⚠ Attention

Ne posez aucun objet sur le dessus de l'appareil. Il pourrait empêcher la circulation de l'air, ce qui risquerait d'endommager, l'appareil et d'annuler la garantie.

7.3 Lighting and Shutdown Procedures

⚠ WARNING

Do not attempt to light the boiler with the burner cover off. Doing so may cause severe bodily injury.

⚠ AVERTISSEMENT

Ne tentez pas d'allumer l'appareil sans que la soit en place. Vous pourriez être victime de blessures corporelles graves.

Before starting your boiler, be sure that all of the functions and limits of the JVS and JVT boilers have been set according to the previous section of this manual (Section 7.2). Follow the instructions outlined below. Read and follow all safety instructions first. A more detailed set of lighting and shutdown instructions are listed on the label located on the boiler.

NOTE: If your boiler is configured to operate on LP gas and the LP tank runs out of fuel, turn off gas at the boiler. After the tank is refilled, the boiler must be relit following the instructions found on the boiler. **DO NOT** attempt repairs on the gas control or heater. Tampering is dangerous and voids all warranties.

⚠ WARNING

If the information in these instructions are not followed exactly, a fire or explosion may result causing property damage, personal injury or death.

⚠ AVERTISSEMENT

Assurez-vous de bien suivre les instructions données dans cette notice pour réduire au minimum le risque d'incendie ou d'explosion ou pour éviter tout dommage matériel, toute blessure ou la mort.

7.3.1 Lighting the Boiler

Lighting instructions are as follows:

1. Verify that the pump system is operating properly:
 - a. Shut off the manual gas valve located outside the boiler.
 - b. Raise the wall thermostat high enough to call for heat.
 - c. The pump should come on immediately. If it doesn't, test the electrical circuits.
2. Pilot Information:
 - a. The JVS boilers do not require manual lighting. The pilot is controlled by the automatic ignition system.
 - b. The JVT boilers do require manual pilot lighting. For access to the pilot burner, remove the louvered airbox cover by loosening the two thumb screws.
 - c. Different models of the JV boiler utilize various gas valves. Although the gas valves may have different control knobs, they are all similar in operation. The JVS gas valve has a two-position knob, ON and OFF. The JVT valve has a three-position knob, ON, OFF and PILOT, some models come with extra push-button (see Figure 12).

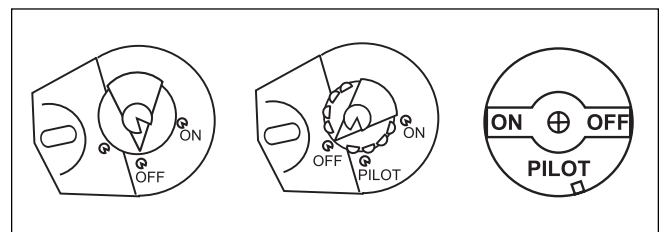



Figure 12. Gas Valves.

3. BEFORE LIGHTING smell all around the appliance area for gas. Be sure to smell next to the floor because some gas is heavier than air and will settle on the floor.

a. WHAT TO DO IF YOU SMELL GAS

- a.1 Do not try to light any appliance.
- a.2 Do not touch any electric switch; do not use any phone in your building.
- a.3 Immediately call your gas supplier from a neighbor's phone. Follow the gas supplier's instructions.
- a.4 If you cannot reach your gas supplier, call the fire department.

All Models:



4. Shut off electrical power to the boiler.
5. Turn the gas valve knob clockwise  to OFF. Use only your hand to push in or turn the gas control knob. Never use tools. If the knob will not push in or turn by hand, don't try to repair it, call a qualified service technician. Force or attempted repair may result in a fire or explosion.
6. Wait five (5) minutes to clear out any gas. Then smell for gas, including near the floor. If you smell gas, STOP! Follow 7.3.1 (3.)a. If you don't smell gas, go to the next step.

JVS Models: (JVT skip 7)

7. Turn gas valve knob counterclockwise  to ON. Restore power to the boiler, and set the thermostat to the desired temperature. The pilot will automatically ignite when there is a call for heat.

JVT Models: (Continuous Pilot)

(JVS skip to step 16)

8. Remove louvered burner cover by loosening the two thumb screws to access the pilot burner.
9. Remove the control box cover to fully access the gas valve.
10. Find pilot - follow metal tube from gas control. The pilot is on the right hand side of the first burner.
11. Turn knob on gas control counterclockwise  to PILOT.
12. Push in control knob or push-button all the way and hold in. Immediately light the pilot with a match using the match holder. Continue to hold the control knob in for about one (1) minute after the pilot is lit. Release knob and it will pop back up. Pilot should remain lit. If it goes out, repeat steps 2 through 8.
 - a. If the knob does not pop up when released, stop and immediately call your service technician or gas supplier.
 - b. If the pilot will not stay lit after several tries, turn the gas control knob to OFF and call your service technician or gas supplier.
13. Replace the louvered airbox cover and tighten the two thumb screws securely.
14. Turn gas control knob counterclockwise  to ON.

15. Replace control box cover.
16. Restore power to the boiler and adjust the thermostat high enough to call for heat to verify the boiler is operating properly.
17. JVS 100-225 ONLY - Adjust two-stage operating control setting to maximum, verify high fire operation. Reduce setting to just below the return water temperature and verify low fire operation.
18. JVS 100-225 ONLY - Set two-stage operating control to desired low fire set point. Generally 20°F below desired loop temp. i.e. for 180°F loop, set two stage operating control at 160°F. Adjust as necessary to maintain proper loop temperature.
19. Set the thermostat to the desired temperature.

7.3.2 Shutdown

7.3.2.1 Main Burner Shutdown (JVT Only):

1. Lower the wall thermostat setting so that there is no call for heat.
2. To turn off the main burners turn the gas valve knob clockwise until it stops at pilot.

7.3.2.2 Complete Shutdown:

1. Lower the wall thermostat setting so that there is no call for heat.
2. Turn off all electrical power to the boiler.
3. Turn the gas valve knob clockwise to "OFF". Do not force the knob.
4. Shut off the external gas supply valve to the boiler.

7.4 High Altitude Burner Air Shutter Adjustment

DANGER

This procedure must be followed exactly and must be performed by a qualified installer or warranty may be voided.

DANGER

Cette manière de procéder doit être faite exactement et accomplie par un installateur qualifié sous risque d'annulation de la garantie.

⚠ DANGER

Read and understand this entire procedure prior to proceeding. Improper adjustment of high altitude shutters may result in a fire, explosion, and/or high levels of toxic gases which may cause property damage, personal injury, or loss of life.

⚠ DANGER

Lisez la manière de procéder dans sa totalité et comprenez-la bien avant de commencer. Un ajustement inadéquat des volets en haute altitude peut provoquer un incendie, une explosion, et/ou des niveaux élevés de gaz toxiques qui pourraient causer des dégâts matériels, des blessures personnelles, voire la mort.

1. STOP! Read the safety information above.
2. Perform System Start-Up in accordance with Section 7.2 of this manual.
3. Remove burner cover by loosening two (2) thumbscrews.
4. Observe flame pattern on all burners. If the flame on any burner is pulsing, unstable or lifting continue with this procedure. Otherwise skip to step 10.
5. On all burners exhibiting an abnormal flame, loosen but do not remove the air shutter locking screw using a 5/16 inch wrench (see Figure 12).
6. On each affected burner, slowly close the air shutter until a normal flame is observed then re-tighten its associated locking screw.
7. Turn the boiler off.
8. Perform System Start-Up in accordance with Section 2A of this manual.
9. Observe flame pattern on all burners. If the flame on any burner is pulsing, unstable or lifting then repeat steps 5 and 6 until all burners are exhibiting a normal flame.
10. Re-install the burner cover and tighten it in place.

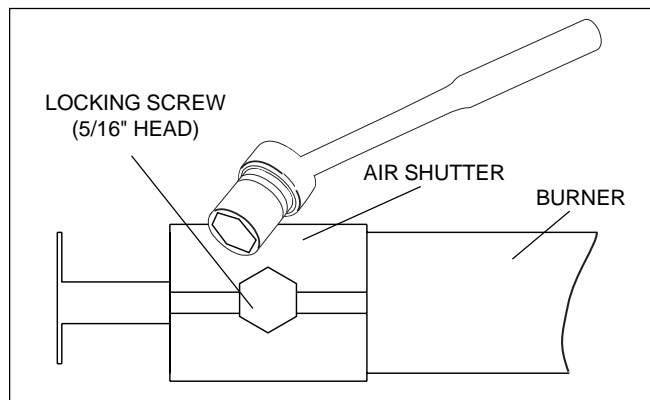

Figure 13. Air Shutter Adjustment.

SECTION 8. Maintenance

8.1 General Maintenance

⚠ WARNING

Improper installation or maintenance can cause nausea or asphyxiation from carbon monoxide in flue gases which could result in severe injury, or death.

⚠ AVERTISSEMENT

Une installation ou un entretien inadéquat peut causer la nausée ou l'asphyxie en raison du monoxyde de carbone présent dans les gaz de combustion et même entraîner des blessures graves ou la mort.

⚠ WARNING**SERVICING SAFETY**

Some of the servicing procedures for the Laars Mini-Therm II JVS and JVT boilers are hazardous because they involve fuel gas, electricity, moving parts and procedures which require testing or temporary bypass of safety controls. For this reason, the heater must be serviced only by a qualified professional service technician.

IMPROPER SERVICE HAZARD

The Mini-Therm II JVS and JVT boilers incorporate unique design features. Incorrect service of this boiler can result in personal injury or damage to property. To avoid such hazards, the heater must be serviced only by a qualified professional service technician.

⚠ AVERTISSEMENT**PRÉCAUTIONS LORS DES RÉPARTATIONS ET DE L'ENTRETIEN**

Certaines procédures d'entretien et de réparation des appareils de chauffage à faibles émissions présentent des dangers, car elles mettent en jeu des gaz combustibles, des composants électriques, des pièces mobiles et des procédures qui nécessitent des mises à l'essai ou la dérivation temporaire des commandes de sécurité. Pour cette raison, l'appareil de chauffage doit être entretenu et réparé uniquement par un technicien professionnel qualifié.

DANGERS D'UN ENTRETIEN INADÉQUAT

Les appareils de chauffage à faibles émissions comportent des caractéristiques techniques uniques. Une réparation ou un entretien inadéquat peut entraîner des blessures corporelles ou des dommages à la propriété. Pour cette raison, l'appareil de chauffage doit être entretenu et réparé uniquement par un technicien professionnel qualifié.

1. Lubricate the water circulating pump per the instructions on the pump.
2. If a strainer is employed in a pressure reducing valve or the piping, clean it every six months.
3. At start-up, and periodically thereafter, the burner flame should be observed. If the flame has the appearance of 'sooting' tips, check for debris near the orifices and call the service technician.
4. Inspect the venting system for obstruction, leakage or corrosion at least once a year.
5. Do not store or use gasoline or other flammable vapors, liquids or chemicals in the vicinity of this or any other appliance.
Ne pas entreposer ni utiliser d'essence ni d'autres vapeurs ou liquides inflammables à proximité de cet appareil ou de tout autre appareil.
6. Do not use this boiler if any part has been under water. Immediately call a qualified service technician to inspect the heater and replace any part of the control system and any gas control which has been under water.
N'utilisez pas cet appareil s'il a été plongé dans l'eau, même partiellement. Faites inspecter l'appareil par un technicien qualifié et remplacez toute partie du système de contrôle et toute commande qui ont été plongés dans l'eau.
7. Be sure that all combustion air and ventilation openings are unobstructed.
8. Upon completion of the installation, inspect the external surfaces of the heat exchanger for fouling based on the following schedule:
24 hours 7 days 30 days 90 days
Once every six months thereafter.
9. If the boiler is not going to be used for long periods of time in locations where freezing occurs, it should be completely drained of all water. To accomplish this, there is a drain valve on the right side of the boiler which can be opened. This will drain the right side of the boiler. There are two plugs located on the left side of the heater which must be removed to drain that side. Both sides must be drained.
10. The gas and electric controls on the boiler are engineered for long life and dependable operation, but the safety of the equipment depends on their proper functioning. It is

strongly recommended that the basic items listed below be inspected by a qualified service technician every year.

- a. Water temperature controls
- b. Pilot safety system.
- c. Automatic gas valves.
- d. Flow sensing safety devices.
- e. Vent dampers and power venters.
- f. Venting system.

NOTE: The Warranty does not cover damage caused by lack of required maintenance, lack of water flow, or improper operating practices.

12. Fouling on the external surfaces of the heat exchanger is caused by incomplete combustion, and is a sign of venting and/or combustion air problems. The heat exchanger can be inspected by using a flashlight and placing a mirror under the burners. An alternate method is to remove the venting and top panel to inspect the exchanger from above. The vent system should be inspected at the same time. If cleaning is required:
 - a. Shut off all power to the boiler.
 - b. Remove the draft hood, venting top, flue collector, and heat exchanger baffles.
 - c. Remove the burners by lifting them off the orifices and pulling them out of the boiler.
 - d. Use a hand-operated spray bottle filled with water, and a wire brush to clean soot and loose scale from the underside of the heat exchanger. **DO NOT USE COMPRESSED AIR, HIGH PRESSURE WATER OR A GARDEN HOSE.**
 - e. Clean any fallen debris from the bottom of the unit.
 - f. Check to make sure the burner ports and pilot assembly are free of debris before returning the burners to their original position.
 - g. Reassemble the boiler in reverse order, making sure to replace the heat exchanger baffles.

8.2 Boiler Components and Their Operation

1. **Gas Valve / Regulator** - The gas valve controls gas flow into the manifold. It provides flow only when the temperature control requires heat and only if all safety controls enable operation. It is also a positive pressure regulator. It regulates the gas pressure in the manifold to specifications addressed earlier in this manual. This is necessary for proper operation of the burner system. JVS 100-225 Only - Gas Valve / Regulator has two output stages controlled by two-stage temperature control.

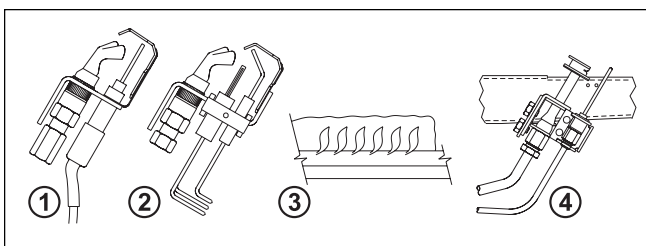

Figure 14. 1) JVS Pilot; 2) JVH Pilot;
3) Main Burner Flame Pattern; 4) JVT Pilot.

⚠ Caution

Two-stage Operating Control (JV100-225 ONLY): Factory setting is 140°F (60°C). This setting is correct for most hydronic heating applications. Adjustments to this setting must be made by an authorized service technician.

2. **Two-stage Temperature Control - JVS 100-225** are equipped with a two-stage temperature control which senses inlet water temperature. It is used to control the firing rate of the main burners, cycling the gas valve between low, high and off.
- 3A. **Ignition Control, JVS** - When the thermostat calls for heat and all limits are satisfied a pilot trial for ignition is initiated. If pilot is not established a 5 minute minimum delay is implemented prior to the next trial for ignition. This cycle repeats until pilot is established or the system is shut down manually.
JVS 100-225 only - Once pilot is established the main valve is enabled and controlled by the two-stage temperature control.
JVS 50-75 only - Once pilot is established the main valve will open until the limit circuit opens.
- 3B. **JVT Flame Control** - The standing pilot JVT models rely on a flame sensor on the gas valve. When the thermostat calls for heat and adequate pilot flame is sensed, the gas valve will open. The valve will remain open until the limit circuit opens.
4. **Pilot Assembly**
JVS - The pilot assembly utilizes an electrode that is used to generate spark to ignite the pilot flame as well as sense flame presence.
JVT - The JVT pilot is lit manually and senses pilot flame via a thermocouple which generates a signal that allows the gas valve to open.
5. **Hi-Limit Switch:** Factory setting is 190°F (88°C). This setting is correct for normal operations, and should only be changed by an authorized service technician. Under no circumstances should the setting exceed 220°F (104°C).
6. **Blocked Vent Switch** - JVS and JVT boilers are equipped with a manual reset blocked vent switch designed to shut the boiler down in the event the vent is completely blocked. The switch is located in the draft diverter opening on the rear of the boiler.
7. **Rollout Switch** - JVS and JVT boilers are equipped with a manual reset rollout switch designed to shut the boiler down in the event a flame rollout situation occurs causing excessive temperatures. The switch is located on the burner cover.

SECTION 9. Troubleshooting

9.1 General Boiler Troubleshooting

Table 8 lists some of the more common problems, causes and solutions encountered when running the boiler. Most problems occur when the boiler is being started for the first time after installation. Careful installation and maintenance will help ensure years of trouble free use from your Laars Mini-Therm II boiler.

⚠ WARNING**SERVICING SAFETY**

Some of the servicing procedures for the Laars Mini-Therm II JVS and JVT boilers are hazardous because they involve fuel gas, electricity, moving parts and procedures which require testing or temporary bypass of safety controls. For this reason, the boiler must be serviced only by a qualified professional service technician.

IMPROPER SERVICE HAZARD

The Mini-Therm II JVS and JVT boilers incorporate unique design features. Incorrect service of this heater can result in personal injury or damage to property. To avoid such hazards, the boiler must be serviced only by a qualified professional service technician.

⚠ AVERTISSEMENT**PRÉCAUTIONS LORS DES RÉPARTATIONS ET DE L'ENTRETIEN**

Certaines procédures d'entretien et de réparation des appareils de chauffage à faibles émissions présentent des dangers, car elles mettent en jeu des gaz combustibles, des composants électriques, des pièces mobiles et des procédures qui nécessitent des mises à l'essai ou la dérivation temporaire des commandes de sécurité. Pour cette raison, l'appareil de chauffage doit être entretenu et réparé uniquement par un technicien professionnel qualifié.

DANGERS D'UN ENTRETIEN INADÉQUAT

Les appareils de chauffage à faibles émissions comportent des caractéristiques techniques uniques. Une réparation ou un entretien inadéquat peut entraîner des blessures corporelles ou des dommages à la propriété. Pour cette raison, l'appareil de chauffage doit être entretenu et réparé uniquement par un technicien professionnel qualifié.

9.2 Troubleshooting Guide

#	Symptom	Cause	Remedy
1.	Pump not operating	A. No power B. Pump defective C. Incorrectly wired	A. Check circuit breakers and power source. B. Replace. C. Recheck wiring diagrams.
2.	Pilot outage	A. Inlet gas pressure too low B. Inlet gas pressure too high causing an unstable blowing pilot C. Weak or defective thermocouple D. Damaged pilot or thermocouple E. Dirty pilot F. Plugged or undersized pilot orifice	A. Consult gas utility company. Inlet gas pressure to boiler should be 5.5" to 10.5" water column on natural gas. 0.0" to 13.0" on propane gas. B. Pressure should be regulated within limits shown above. C. Replace thermocouple. D. Replace. E. Blow dust or lint out of pilot. F. Clean or replace pilot orifice.
3.	Flame roll-out on start-up	A. Blocked flue B. Pilot out of position (delayed ignition) C. Blocked heat exchanger or flue D. Refractory tile out of place E. Altered draft diverter	A. Remove blockage. B. Correct pilot position. C. Clean and correct as necessary. D. Correct or replace tile as necessary. E. Install factory-provided draft diverter.
4.	Spillage at draft hood	A. Cold chimney B. Vent pipe pitches down to chimney C. Blocked chimney D. Draft hood altered E. Pre-fabricated chimney with incorrect cap	A. Allow boiler to operate 5 minutes to create draft action. B. Reinstall vent pipe to pitch up from boiler to chimney. C. Remove blockage. D. Install factory-provided draft diverter. E. Install U.L. listed vent cap.
5.	Flame has lazy yellow tip	A. Low primary air	A. Correct manifold pressure according to rating plate. Correct orifice size if necessary (see parts list). Clean burner ports if dirty. Verify correct fuel type.
6.	Not enough heat	A. Inadequate gas supply B. Low manifold gas pressure C. Boiler size inadequate D. JVS 100-225 only - Boiler not going to high fire.	A. Gas meter too small. Gas line from meter to boiler too small. B. Gas pressure on boiler manifold (at normal firing rate) should be adjusted to 4.0"W.C. natural gas, 9.0"W.C. propane. C. Replace with boiler of higher input. D. Check operation and setting of two-stage operating control.
7.	Pump noisy	A. Air in volute B. Worn coupling or bearings	A. Bleed air from volute. Check pump alignment. B. Replace worn parts.
8.	Boiler pounding or knocking	A. Too low water flow through boiler	A. Check temperature rise between inlet and outlet boiler piping. 15°F to 25°F temperature rise is recommended. If temperature rise is over 25°F, increase pipe size or pump capacity or locate obstruction. Check for stuck closed zone valves. Check for zone pumps not operating. Check for closed valve in system.
9.	Boiler condensing	A. Low water temperature	A. Flue product moisture will condense at the start-up until the boiler water temperature reaches the normal operating conditions.
10.	Pump cavitates or low water pressure at boiler gauge or bubbles in system at high temperature	A. Defective fill valves or pressure regulator B. Oversized expansion tank C. Expansion tank piped incorrectly	A. Replace. B. Replace. C. Repipe expansion tank to suction size of pump.
11.	Pressure relief valve opens	A. Water-logged expansion tank	A. Drain $\frac{2}{3}$ of the water from the expansion tank.
12.	Pilot is lit but main burners will not come on	A. Gas valve not at "on" position (JVT) B. Boiler off on hi-limit control C. Boiler incorrectly wired D. Boiler off on blocked vent switch E. Boiler off on flame roll-out switch F. Broken wire in thermostat circuit or defective thermostat G. JVS 100-225 Only - Two-stage operating control not functioning or loose contact.	A. Turn knob to "on" position. B. Check for low water flow or hi-limit setting. C. On single or multiple zone systems with zone valves, room thermostat should be wired to R & W terminals. For multiple zone systems with zone pumps, thermostats for extra zones should be wired to R & A terminals. D. Remedy as in symptom #4. Reset the manual reset switch. E. Remedy as in symptom #3. Reset the manual reset switch. F. Check continuity through thermostat circuit with wires disconnected from R & W. G. Check continuity and operation through two-stage operating control.
13.	Boiler short cycles	A. Heat anticipator in room thermostat set too low B. Low water flow through boiler C. Hi-limit switch may be set too low	A. Increase setting (0.8 - 1.0 is usually satisfactory). B. Increase size of pump or increase piping size. C. Increase setting to at least 20°F over outlet water temperature.

Table 8. Troubleshooting Guide.

9.3 Troubleshooting Honeywell S8600 Intermittent Pilot System

Some boilers may be equipped with an ignition module that shuts off pilot gas if pilot fails to light.
To reset, interrupt power to heater

Start

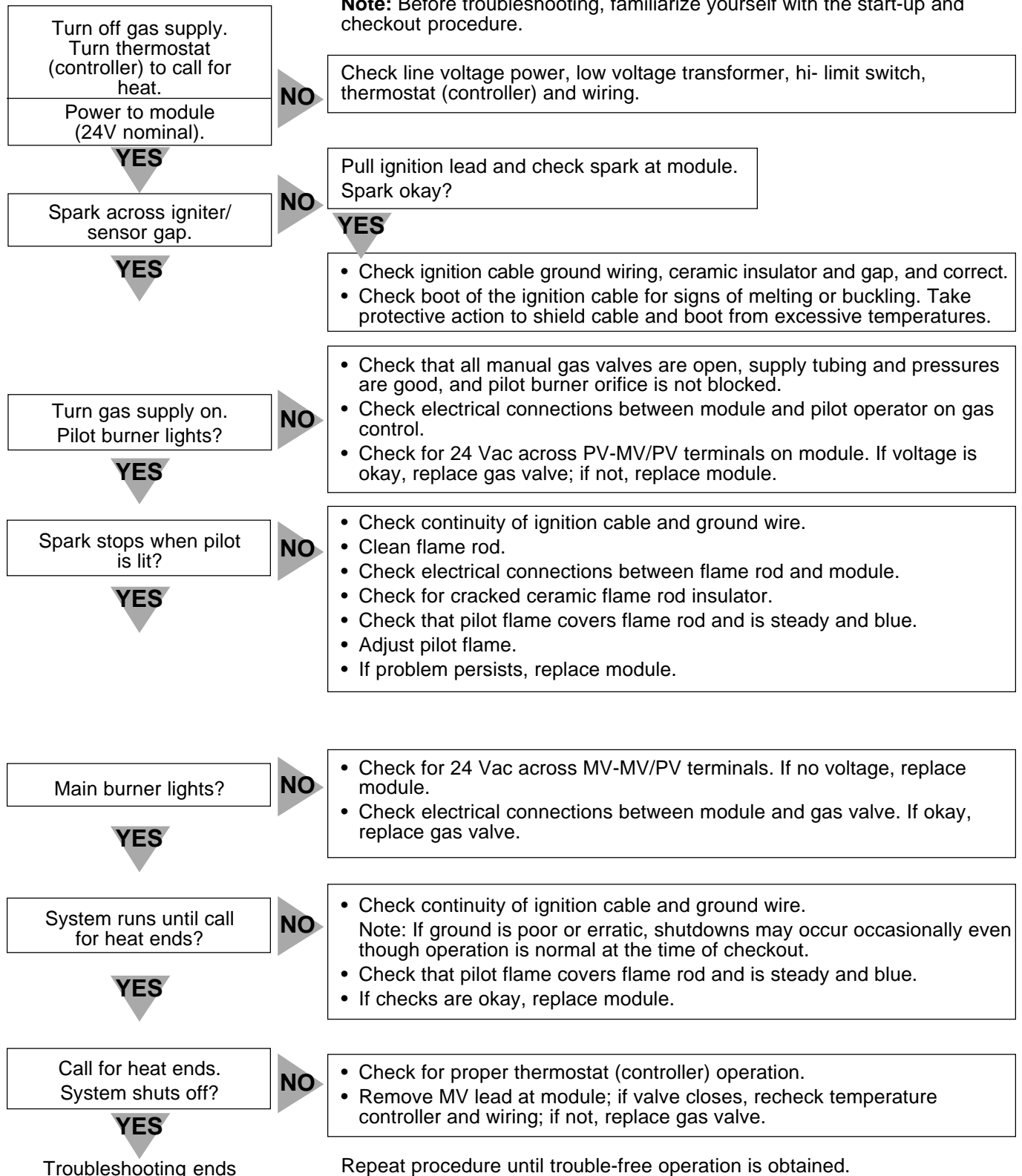

9.4 Electrical Troubleshooting

1. Remove the control box cover on the front of the boiler.
2. Verify that 115V is reaching the boiler by testing across the black wire on the pump relay and the white wire on the transformer.
3. Verify 24V transformer output by placing the meter leads on the yellow and red wires. If 24V is not evident, replace the transformer. Perform the following series of tests with one meter lead attached to the yellow wire on the transformer.
4. Place the second lead on the "W" connection on the terminal board. Turn the wall thermostat high enough to call for heat. If the meter fails to register 24V, the thermostat or its circuit may be defective.
5. Make sure thermostat is set high enough to call for heat. Place second lead on the "A" connection on the terminal board. If voltage is evident, skip to step 6. If no voltage, test the circuit between the red wire on the transformer and terminal 4 on the pump relay; from terminal 6 on the pump relay and the "A" connection on the terminal board; and from the purple wire terminal on the pump relay to the "W" connection on the terminal board. If no output is found, the connections or the pump relay could be defective.
6. Place the second lead on the orange wire terminal on the hi-limit switch. If no voltage across the switch, check for defective hi-limit, open circuit due to excessive water temperature, or a low temperature setting.
7. Place the second lead on the orange wire terminal on the blocked vent safety switch. If voltage is present, the vent damper is open. If voltage isn't present, connections or the vent damper could be defective.
8. Verify the voltage across the blocked vent and roll-out safety switches.
9. On JVT boilers, test for voltage at the "TH" terminal on the gas valve. If none is found, follow steps 1 through 8.
10. If it is determined that there is voltage to the gas valve, the pilot is lit and the thermocouple is properly positioned, and the thermostat is set high enough to call for heat, the gas valve or the pilot thermocouple may be defective.
11. There are two tests necessary to make sure the problem is not in the pilot thermocouple. The first test can be performed by unscrewing the compression fitting on the gas valve, and placing one millivoltmeter lead on the center post of the tube and the other lead on the copper tubing. If the meter shows a reading of approximately 30 millivolts, proceed to the second test. If it

doesn't, replace the pilot thermocouple. The second test requires the use of a Millivolt Reading Adapter to test the thermocouple under load. Once again, remove the pilot thermocouple compression fitting from the gas valve. Replace it with a Millivolt Reading Adapter, and screw the thermocouple fitting into the end of the adapter. Attach one lead from the millivoltmeter to either side of the adapter and the other lead to ground. Light the pilot and set the wall thermostat high enough to call for heat. With the boiler firing, take a millivolt reading. It should be in the 15 millivolt range. If it isn't, replace the pilot thermocouple.

Caution

Label all wires prior to disconnection when servicing controls. Wiring errors can cause improper and dangerous operation. Verify proper operation after servicing.

ATTENTION

Au moment de l'entretien des commandes, mettez des étiquettes sur tous les fils avant de les débrancher. Des erreurs de câblage peuvent causer un fonctionnement inadéquat et dangereux. Vérifier que tout fonctionne bien après votre entretien.

SECTION 10. Glossary

10.1 Glossary of Terms

Air Vent

Another device used to purge air from the circuit. Should be located at the highest point in the circuit.

Branch

The section(s) of supply and return piping, including the heat distribution units (see below), connected directly to the trunk. Also referred to as a "zone."

By-pass

A section of pipe (including an adjustable valve) that diverts part of the water flow from the boiler outlet to the inlet, adjusted to maintain minimum flow requirement (GPM) or inlet water temperature.

Circuit

Entire water circulation piping, beginning and ending at the boiler (Series Loop System).

Expansion Tank (Compression Tank)

Installed in the circuit to accommodate excess water produced by heat expansion, and to maintain the system pressure.

Heat Distribution Units

Transfers heat from the water supplied by the boiler to the area to be heated through the use of baseboard, convector, radiator, finned tube. Also known as "radiation."

Isolation Valve

Used to isolate the boiler from the circuit. It minimizes the amount of water drained from the system.

Primary-Secondary Piping

Two or more interconnecting circulating loops, each with its own pump.

Reverse-return Piping

Balanced, equal flow (first in, last out) piping. Utilized with multiple boilers and/or radiation. Applied with single system pumps, or primary-secondary pumps.

Side Wall Power Venter

This Laars accessory allows the boiler exhaust to be routed horizontally through an adjoining outside wall, rather than gravity venting with a chimney or stack when local codes allow.

System Purge Valve

A device used to purge air from the circuit. Should be located as close as possible to the cold water feed, but not immediately after the cold water feed.

Trunk

The section of piping which connects the boiler return and supply with the branch(es). Also known as a "main" or "header." Should be same size as boiler inlet/outlet connections.

Vent Damper (optional in Canada)

Standard on JV boilers. This energy-saving device prevents heated air from exiting the open vent when the boiler is not operating.

Zone Pump

Circulators installed in branch piping that divert hot water coming from the boiler into various areas (zones) of a building.

Zone Valve

Diverts hot water from the boiler into various areas (zones) of a building.

SECTION 11. Replacement Parts

11.1 Ordering Information

To order or purchase parts for the Laars Mini-Therm II JVS or JVT boiler, contact your nearest Laars Representative. If you need assistance in finding a local dealer or distributor, contact the Technical Service Department.

NOTE: To supply the correct part it is important that you state the model number, serial number and type of gas when applicable. This information is on the rating plate on the heater.

11.2 Parts List

The following three pages contain a parts list and a general exploded view to aid in parts identification. Please refer to these pages when ordering parts for your JVS or JVT boiler.

11.3 Exploded View

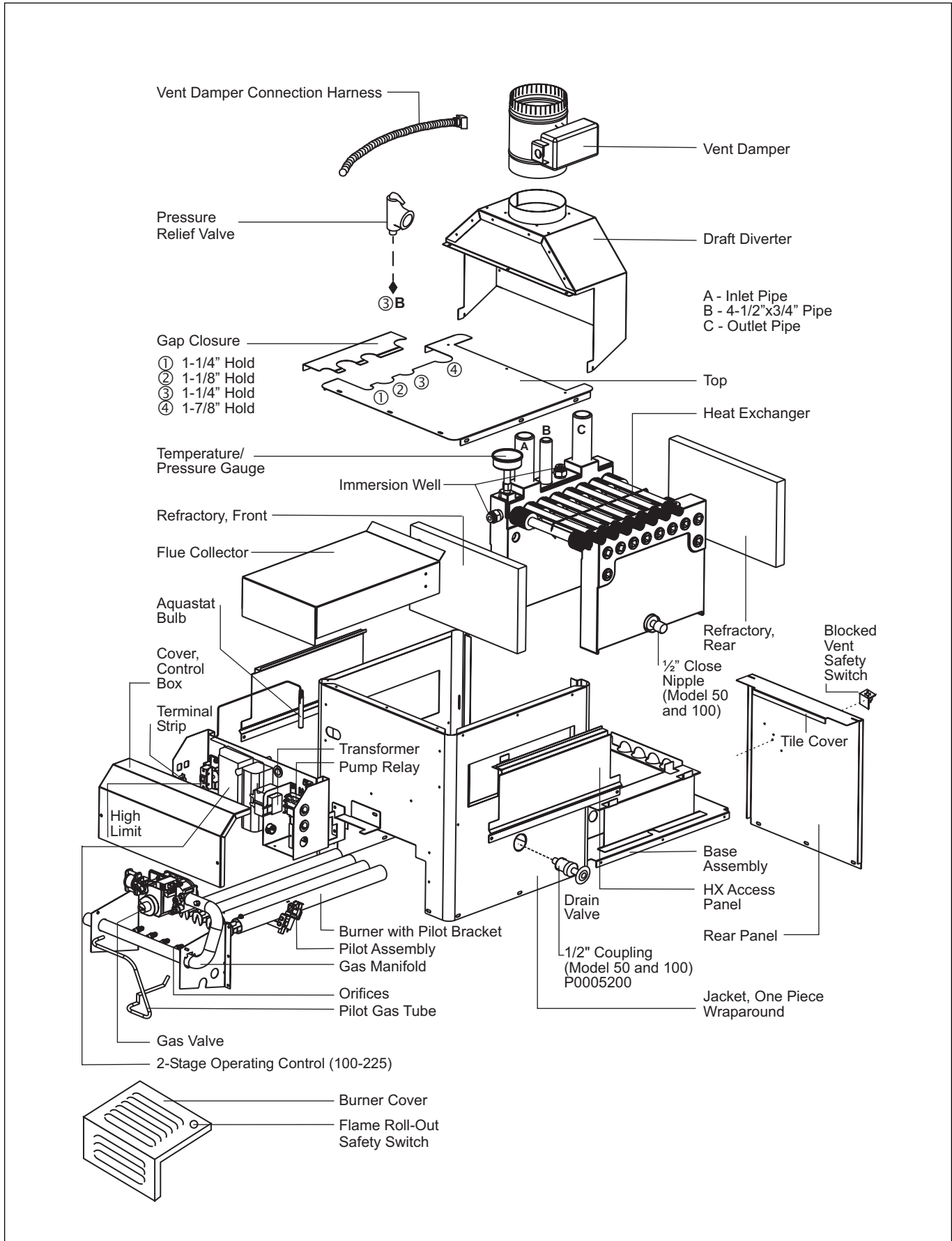

Figure 15. Parts Identification.



H0071400Y

LAARS 
Heating Systems Company

A subsidiary of **BRADFORD WHITE** Corporation

800.900.9276 • Fax 800.559.1583 (*Customer Service, Service Advisors*)

20 Industrial Way, Rochester, NH 03867 • 603.335.6300 • Fax 603.335.3355

1869 Sismet Road, Mississauga, Ontario, Canada L4W 1W8 • 905.238.0100 • Fax 905.366.0130

www.Laars.com

Litho in U.S.A. © Laars Heating Systems 0805 Document 1025Y